

Test results of INA241 current sense amplifier

1 Schematic snippet

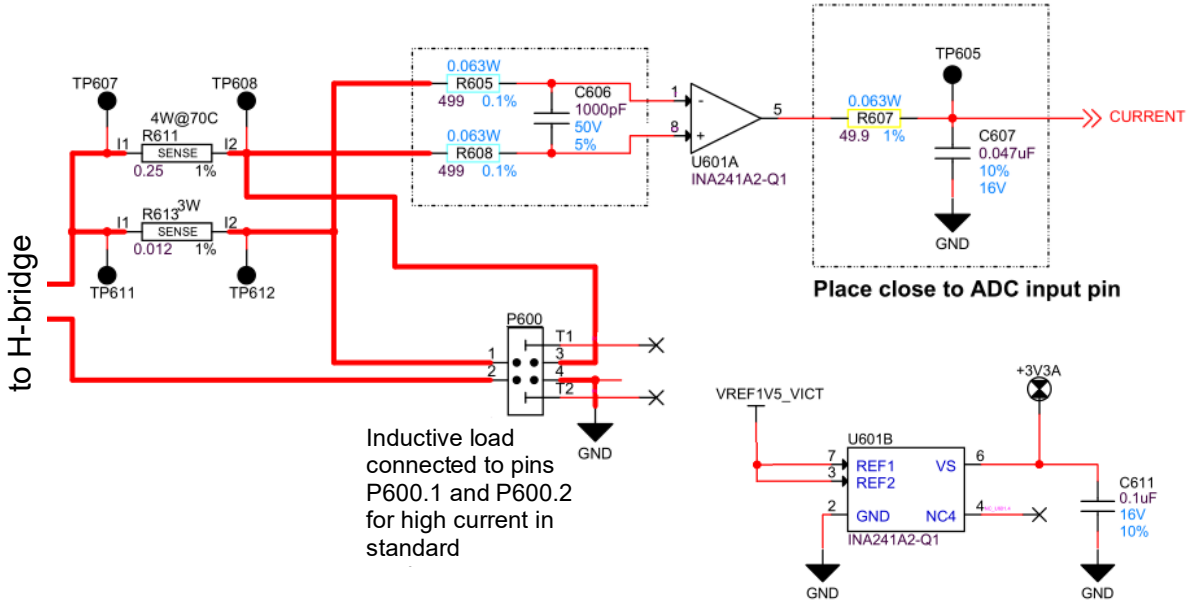

2 Layout snippet

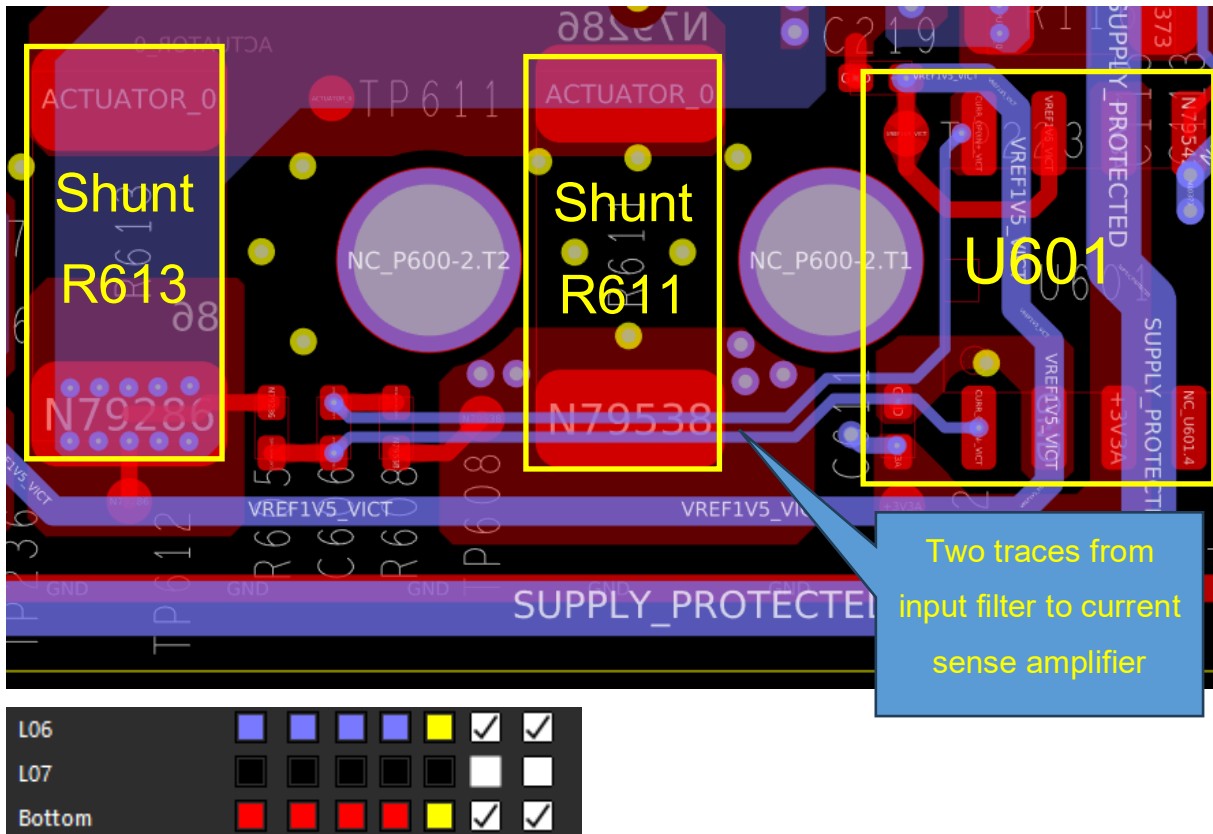

Layer 7 is a solid ground plane.

3 Issue description

The following screenshots show the datalogger function of our configuration software for our hardware product configured to show the current control loop related signals:

Red: current demand (100 Hz sine wave, demand offset 50 % of maximum current, demand amplitude 50% of maximum current)

Green: actual current

Blue: PWM demand value (duty cycle in percent)

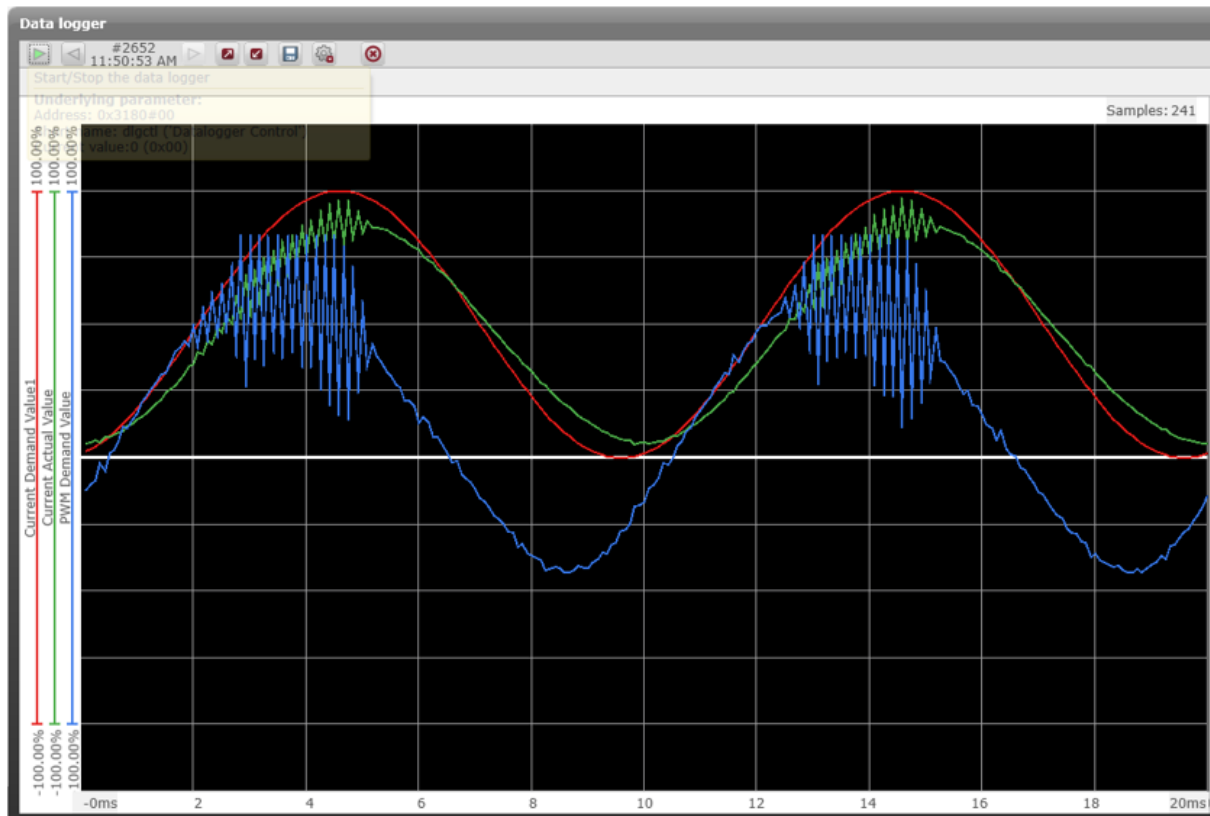

The oscillations with control loop p-gain (= 4) can clearly be recognized.

With reduced filter resistors (20 Ohm each) and a filter capacitor of 10 nF the control loop p-gain can be increased, oscillation starts with p-gain set to 6:

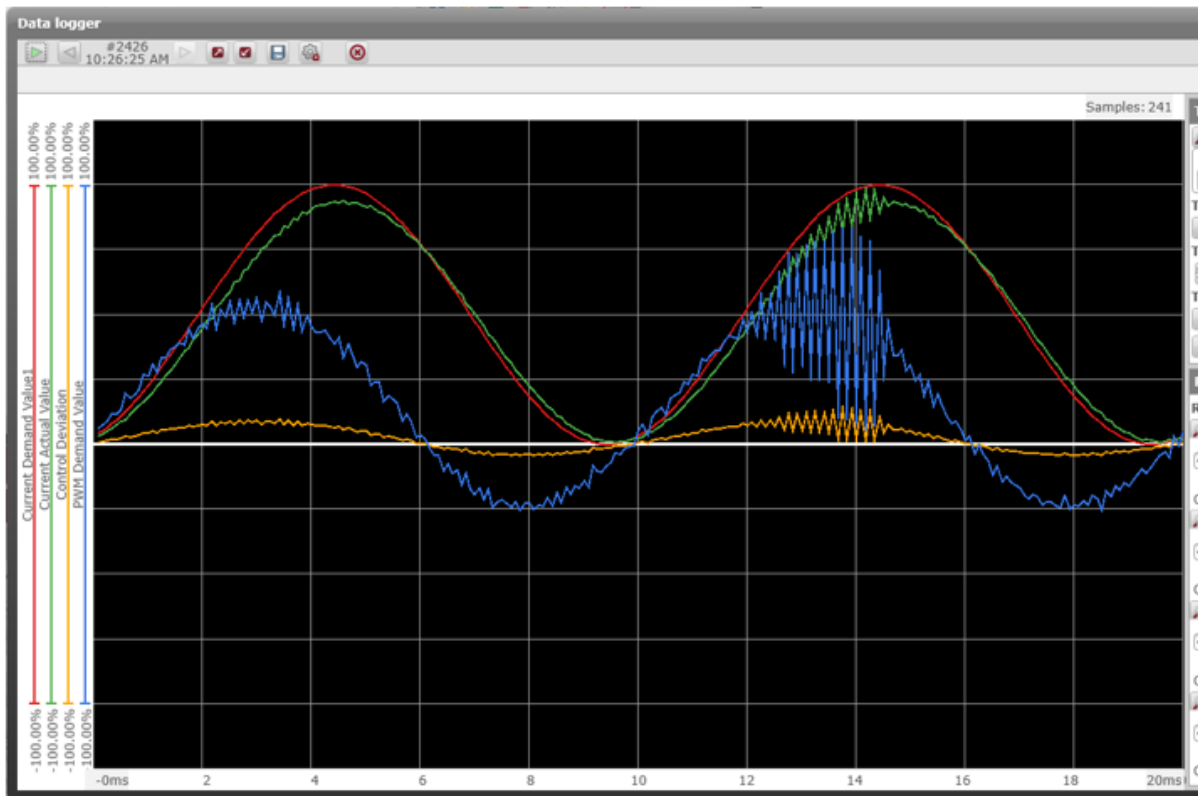

Additional orange signal: current control error

With switched filter inputs and original filter values (2x 499 Ohm and 1 nF) the current control loop p-gain can be set to 7 and no significant oscillation occurs:

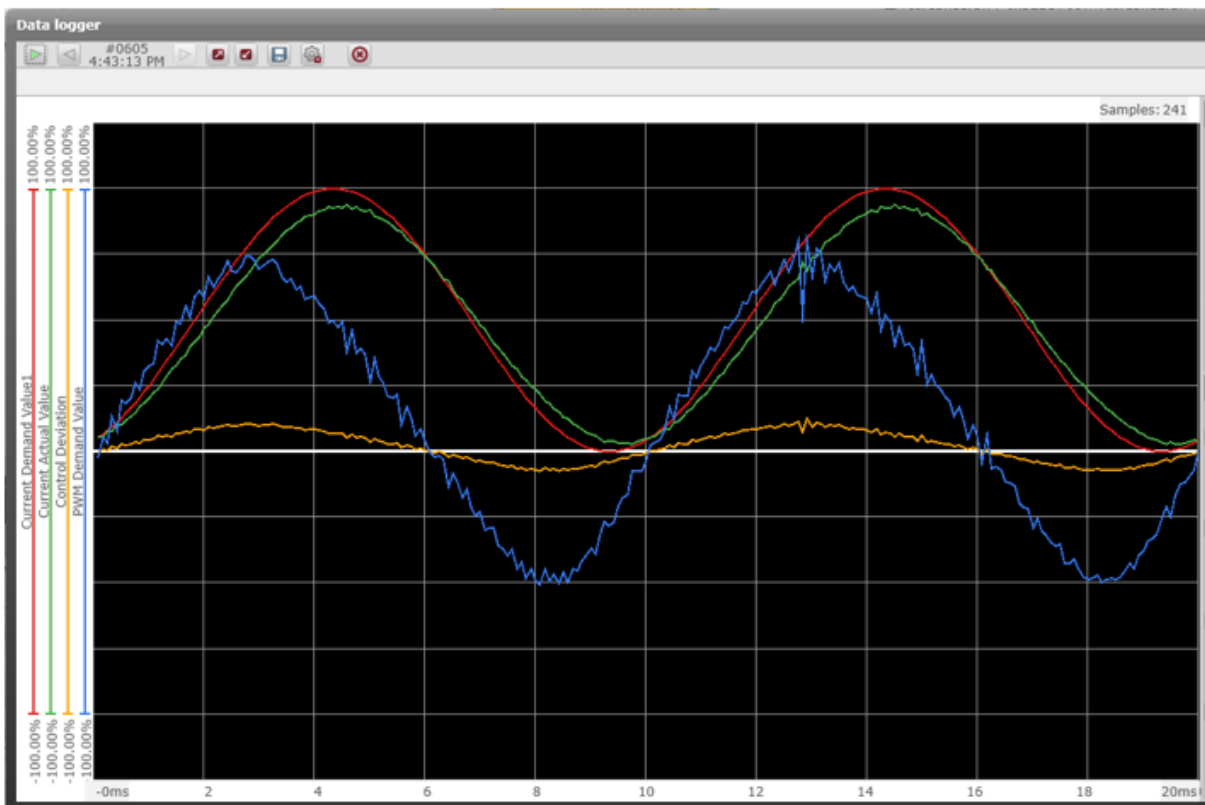

4 Time signal measurement results

The “current signal” of channel C3 is measured at test point TP605 (ADC input) to GND.

4.1 Current sense input wiring according to schematics

- R605, R608 = 499 Ohm

Positive current direction shown:

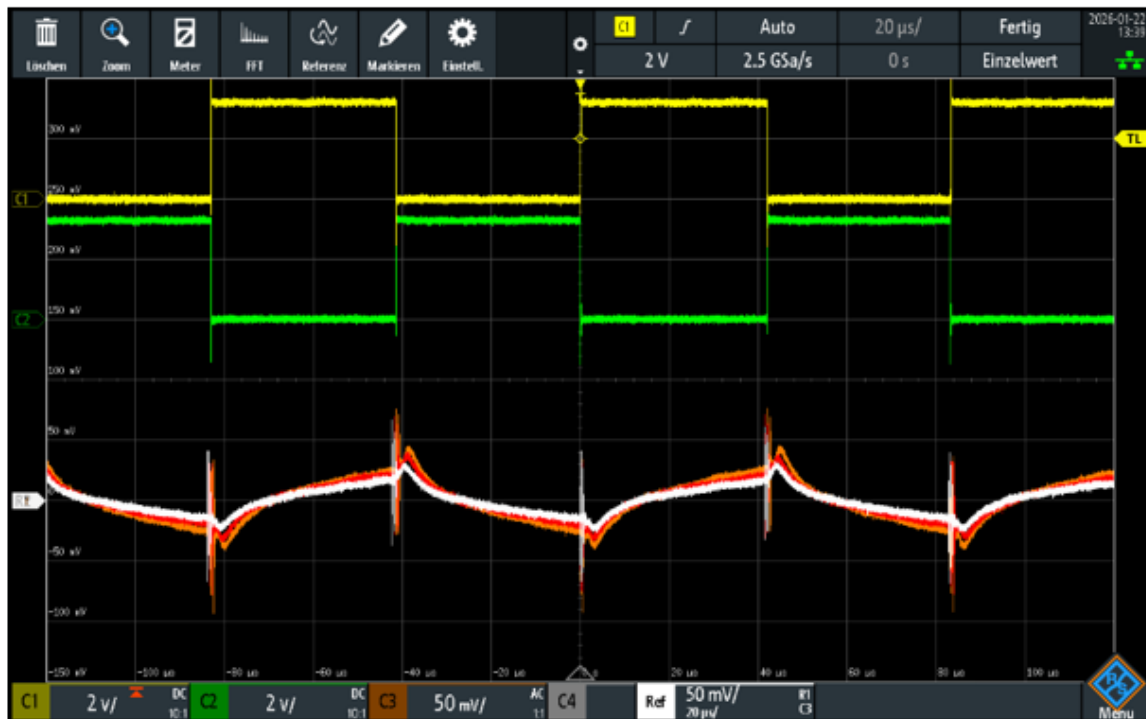

C1 PWM @ 30 Vsupply

C2 PWMINV @ 30 Vsupply

C3 current signal AC @ 30 Vsupply

R1 (white) current signal AC @ 18 Vsupply

R2 (red) current signal AC @ 24 Vsupply

4.2 Current sense input wiring according to schematics, R605, R608 = 0 Ohm

Positive current direction shown:

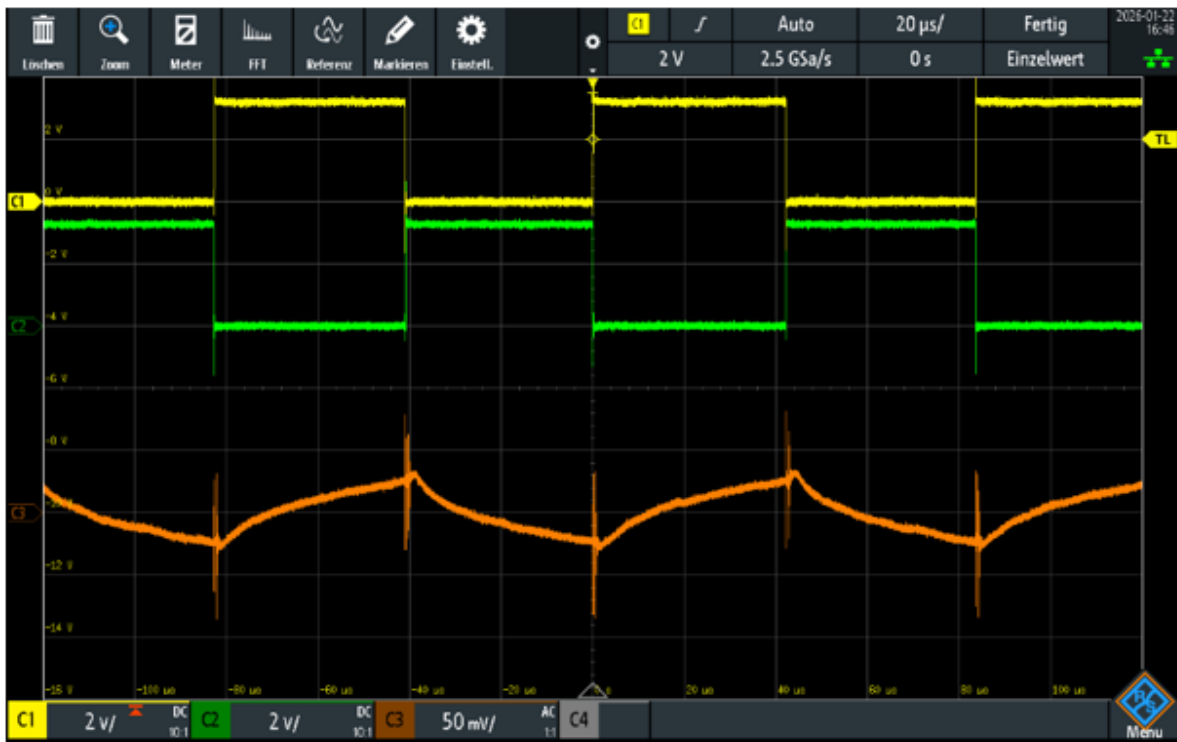

- C1 PWM @ 24 Vsupply
- C2 PWMINV @ 24 Vsupply
- C3 current signal AC @ 24 Vsupply

4.3 Current sense input wiring with switched filter inputs

- Inverted on board current measurement by exchanging shunt resistors R613 and R611 and using P600.2 and P600.3 instead – this was easier to achieve in the layout and leads to the same as switched connections of filter resistors to shunt resistors
- R605, R608 = 499 Ohm 0,1 %

Positive current direction shown:

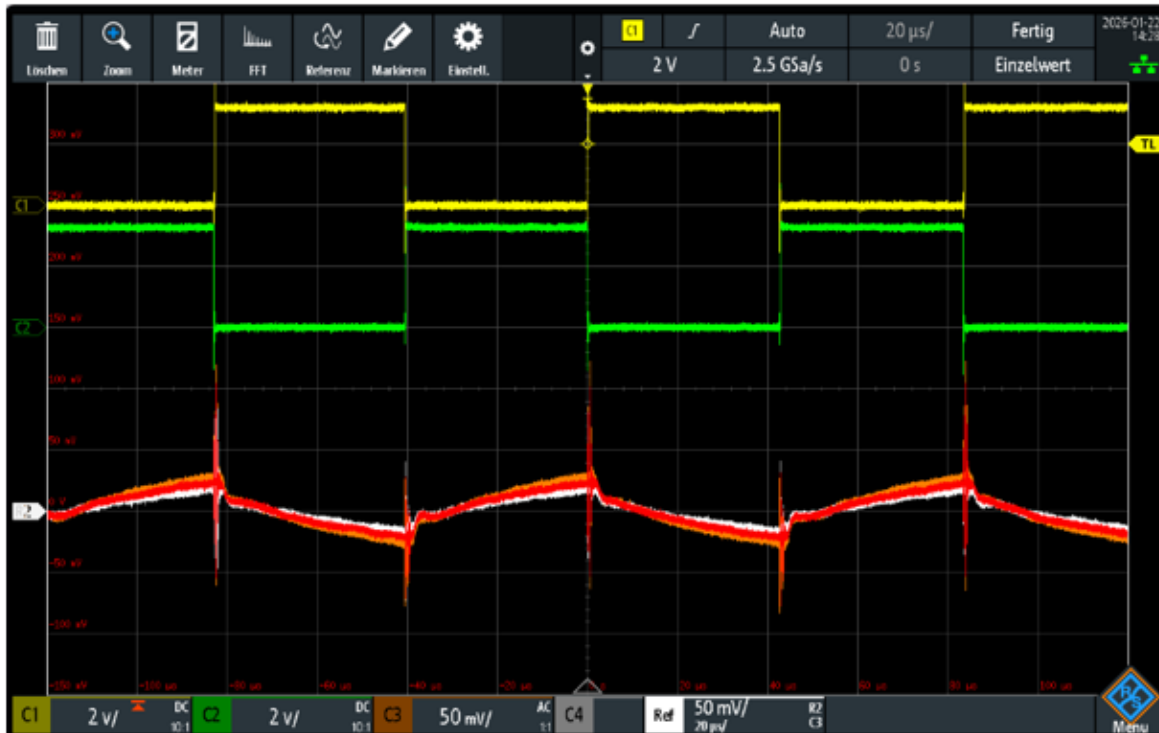

C1 PWM @ 30 Vsupply

C2 PWMINV @ 30 Vsupply

C3 current signal AC @ 30 Vsupply

R1 (white) current signal AC @ 18 Vsupply

R2 (red) current signal AC @ 24 Vsupply

4.4 Current sense input wiring with switched filter inputs, R605, R608 = 0 Ohm

Positive current direction shown:



- C1 PWM @ 24 Vsupply
- C2 PWMINV @ 24 Vsupply
- C3 current signal AC @ 24 Vsupply

5 Conclusions

- The shape of the current signal (e-function) with filter resistors R605 and R608 set to 0 Ohm is similar for both input connections (4.2, 4.4).
- At higher PWM duty cycles the ADC (adjusted in the center of PWM high and low phase samples) samples in the more bent region of the current signal.
- The shape of the current signal for the two different input connections to the shunt resistors is different if filter resistors R605 and R608 have value 499 Ohm 0,1%. In section 4.1 there is an e-function shape and in section 4.3 there is a more gradually rising signal shape with a little step at the beginning (limited CMRR?).
- In switched input connection with 499 Ohm filter resistors the ADC always samples in the more gradual signal shape region (even with short PWM phases) and might not degrade the current control loop stability.