

USB2.0 Re-Driver

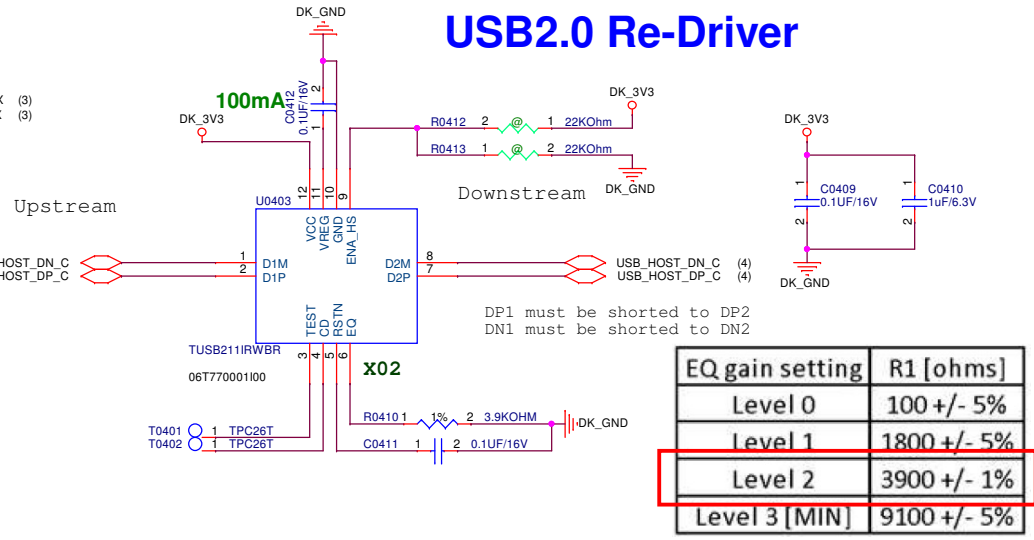

EQ gain setting	R1 [ohms]
Level 0	100 +/- 5%
Level 1	1800 +/- 5%
Level 2	3900 +/- 1%
Level 3 [MIN]	9100 +/- 5%

OVER TEMPERATURE PROTECT (Non Inverting Comparator with Hysteresis)

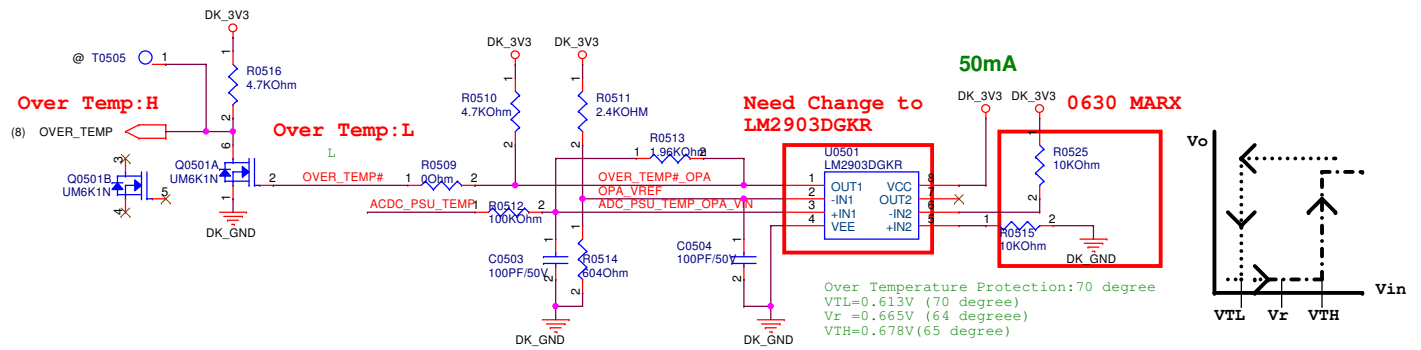

Output Voltage External Control:MCU_DAC

0630 MARX

