

### CURRENT GAIN CONTROL CIRCUIT

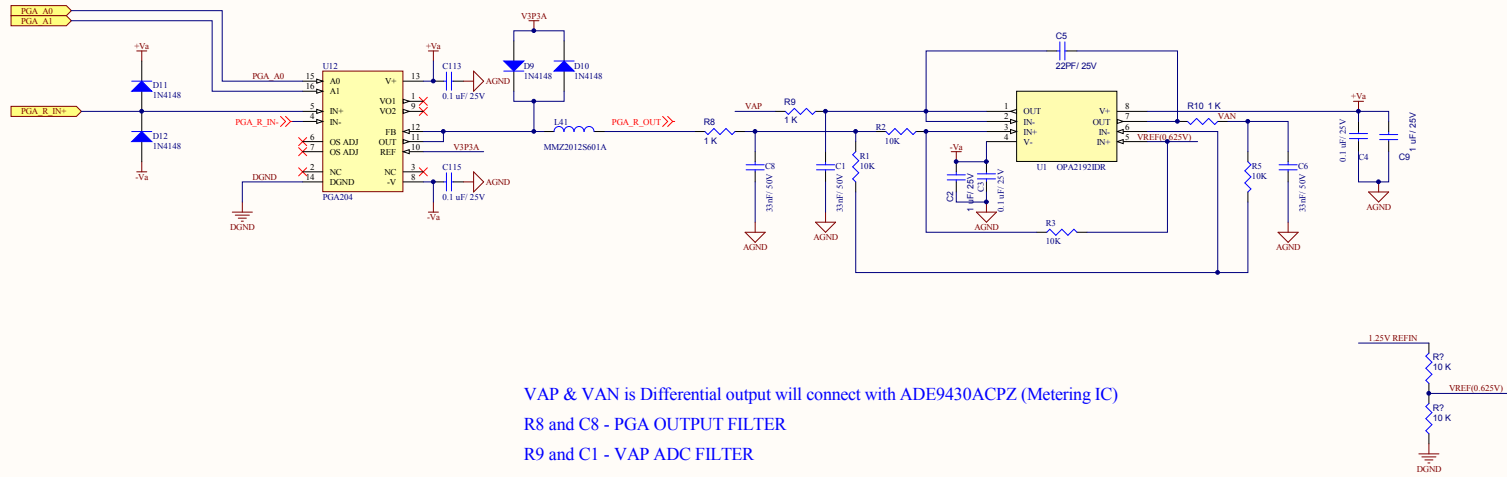

VAP & VAN is Differential output will connect with ADE9430ACPZ (Metering IC)

R8 and C8 - PGA OUTPUT FILTER

R9 and C1 - VAP ADC FILTER

R10 and C6 - VAN ADC FILTER

C5- Differential noise suppression

R1 Input bias

R5 Gain Resistor

R3 Feedback Resistor

Vref is coming from ADE9430 i.e 1.25V and we have used 1/2 by resistor divider