

Thin Film Pyroelectric Dual Channel Sensor

Introduction

Pyreos thin film pyroelectric IR sensors for gas detection and concentration measurement offer exceptionally high responsivity, low microphonics and class leading thermal and electrical stability. This high performance current mode sensor achieves a signal to noise of ~10,000 and offers a fast, stable response over a wide operating frequency range. The sensor elements are built into a low noise circuit that has an internal CMOS op amp, with a 10 GΩ feedback resistor outputting a voltage signal centred around half the supply rail.



Sensor Characteristics	
Filter aperture	2.6 mm square
Element size	1000 μm x 1000 μm
Package	TO39
Responsivity ¹	150,000 V/W
D* ¹	3.5 x 10 ⁸ cm√Hz/ W
Noise ¹	70 μV√Hz

Electrical Characteristics	
Max. Voltage	8.0 V
Min. Voltage	2.7 V
Output voltage normalised around mid-rail	
Microphonics	S _{vib} ~2 μV/ g at 10Hz
Time Constant	~12 ms
Operating Temperature	-40 to +85 °C
Storage Temperature	-40 to +110 °C
Filters	See "Filters Available"

¹ 10 Hz, 500 K, room temperature, without window and optics

Frequency Characteristics

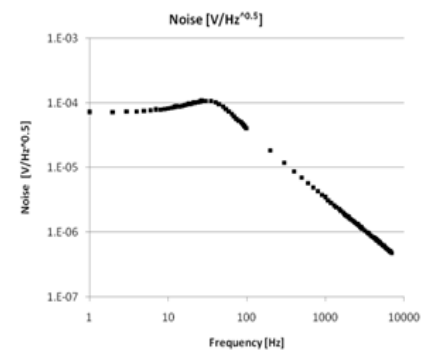
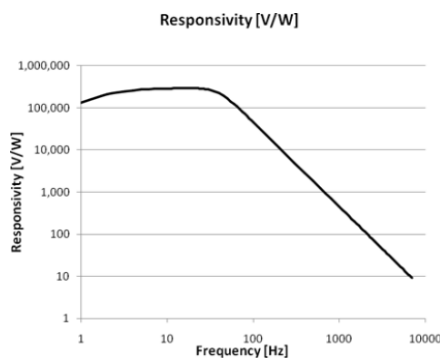
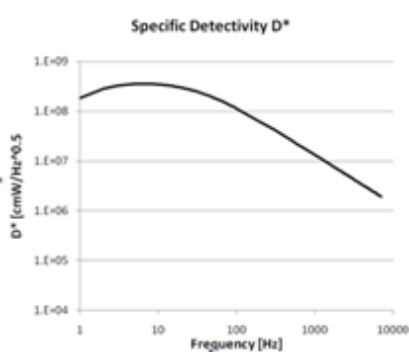

Please note: the information contained in this document is subject to change without further notification. Pyreos reserves the right to alter the performance and any resulting specification. Pyreos may choose not to supply any engineering sample devices as a commercial product. No responsibility is accepted for any consequential loss incurred. Pyreos Ltd, SMC, Alexander Crum Brown Road, Edinburgh EH9 3FF, UK. Tel: +441316507009, www.pyreos.com

Package Information

Filter window size

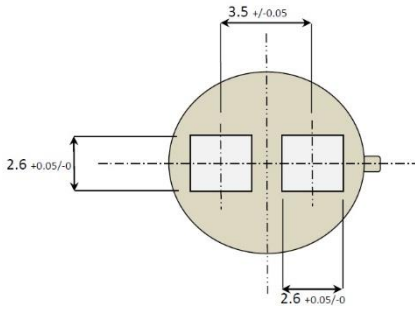

Top View

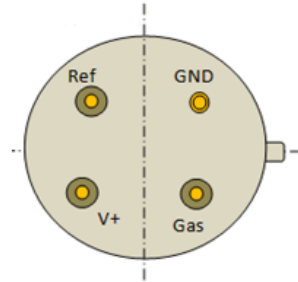

Bottom View

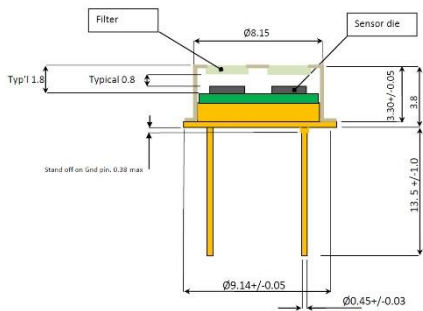

Package dimensions

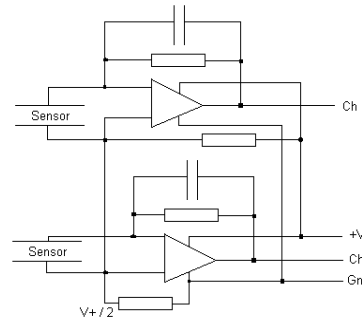

Internal Schematic

Recommended Circuit Diagram

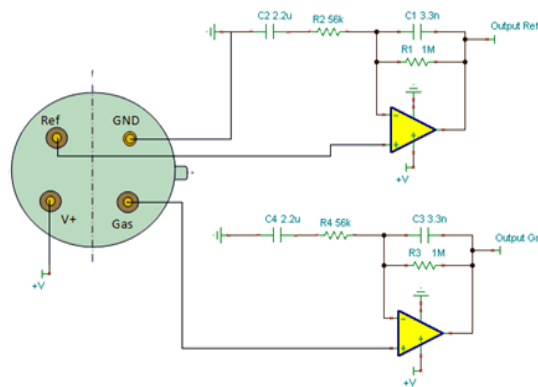

Please note: the information contained in this document is subject to change without further notification. Pyreos reserves the right to alter the performance and any resulting specification. Pyreos may choose not to supply any engineering sample devices as a commercial product. No responsibility is accepted for any consequential loss incurred. Pyreos Ltd, SMC, Alexander Crum Brown Road, Edinburgh EH9 3FF, UK. Tel: +441316507009, www.pyreos.com

Filters Available

Pyreos has a range of standard filters available. The part numbers below have a combination of the Ref. filter and a filter specific to each gas.

Filter	Part number	CWL μm / (HPB nm)
CO ₂	PY0234	4.26 / (180)
CO	PY0305	4.64 / (180)
CH ₄	PY0317	3.30 / (160)
H-C	PY0261	3.375 / (190)
SO ₂	PY0303	7.30 / (200)
NO	PY0304	5.30 / (180)
NO ₂	PY2055	6.20 / (200)
CO ₂ (Narrow)	PY1943	4.30 / (110)
CO ₂ (Special)	PY0238	4.43 / (60)
CO (Narrow)	PY0259	4.64 / (90)
Ref	All	3.91 / (90)

Order Information

Please quote PY-ITV-DUAL-TO39(3+1) and your desired filter combination or quote specific part number PYXXX as per filter table. Contact: sales@pyreos.com