

Operational Amplifier Stability

Collin Wells

Texas Instruments

HPA Linear Applications

2/22/2012

The Culprits

Capacitive Loads!

Reference Buffers!

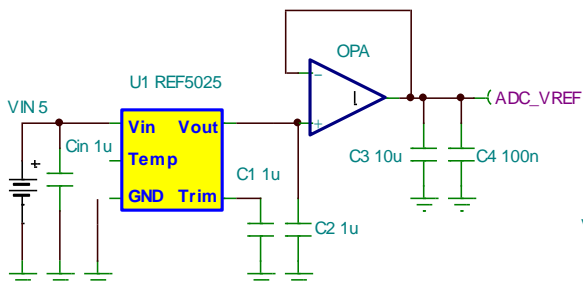

Cable/Shield Drive!

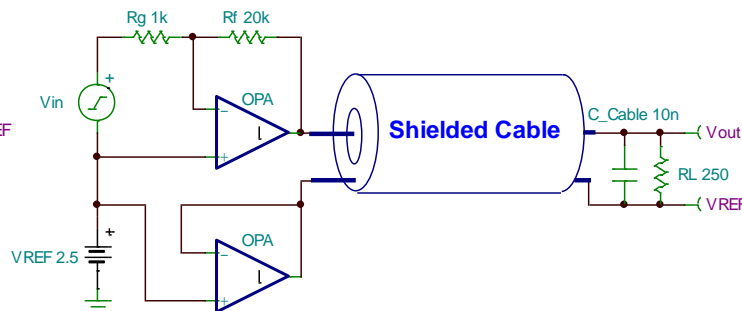

MOSFET Gate Drive!

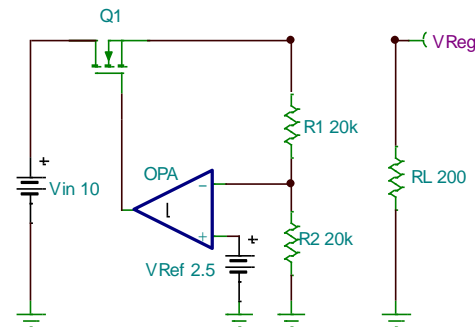

High Feedback Network Impedance!

Transimpedance Amplifiers!

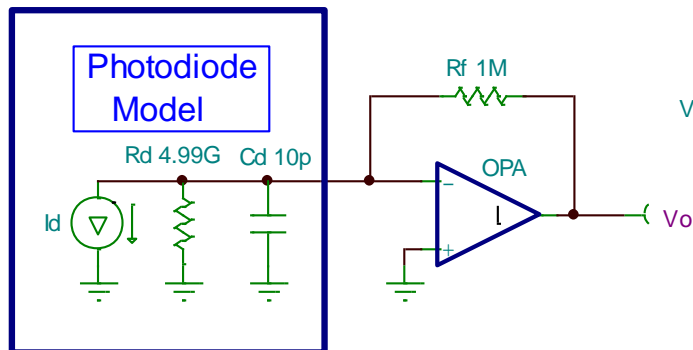

High-Source Impedance or Low-Power Circuits!

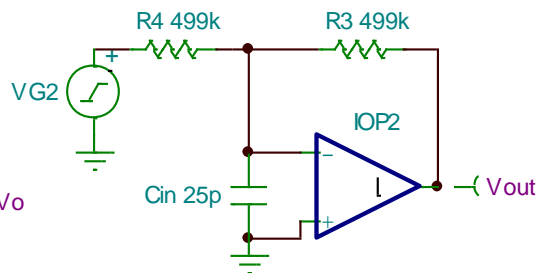

Attenuators!

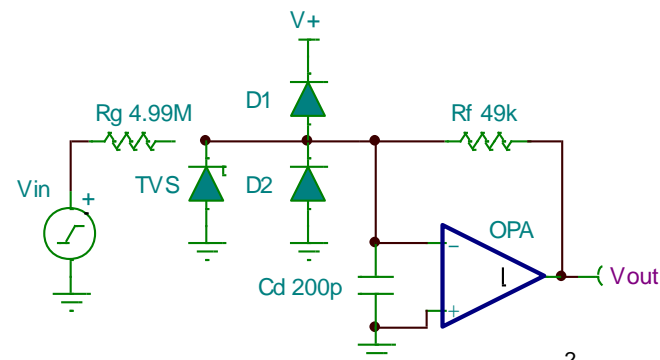

Just Plain Trouble!

Inverting Input Filter??

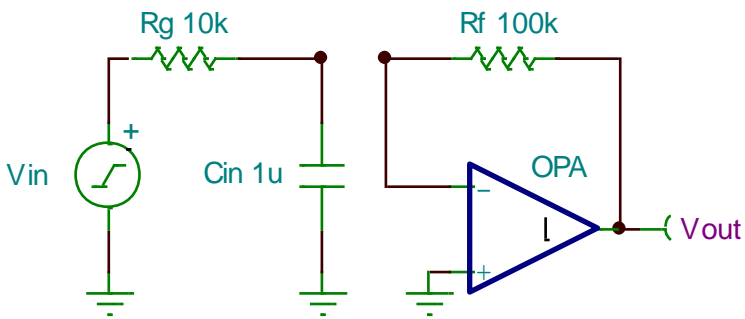

Oscillator

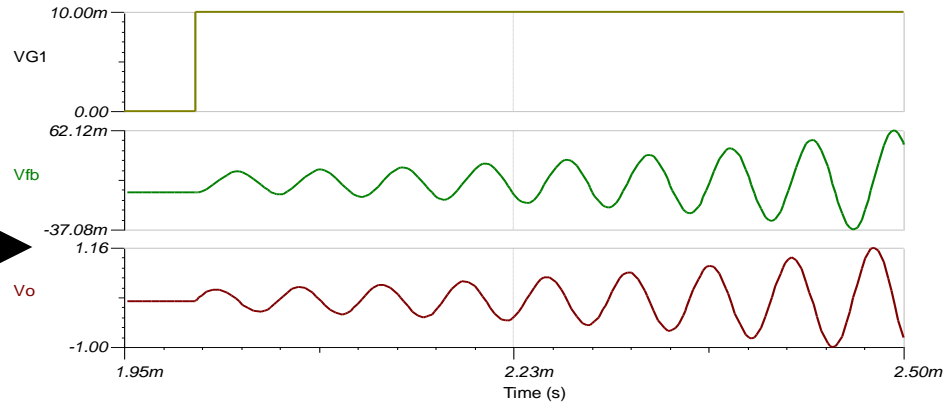

Output Filter??

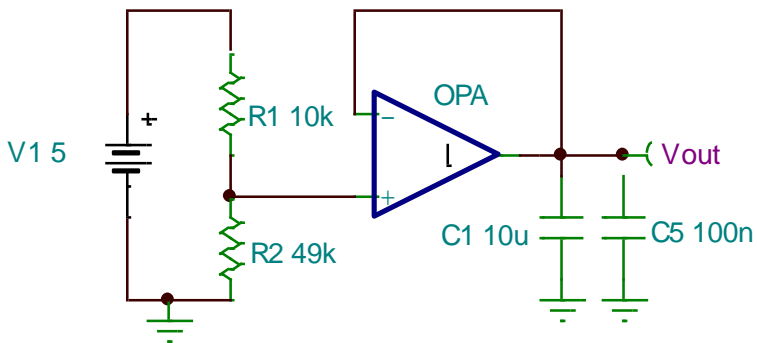

Oscillator

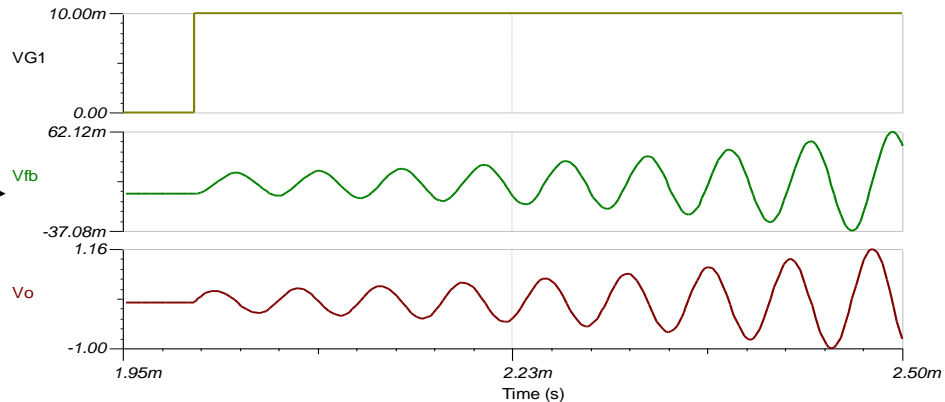

Recognize Amplifier Stability Issues on the Bench

- Required Tools:
 - Oscilloscope
 - Step Generator
- Other Useful Tools:
 - Gain / Phase Analyzer
 - Network / Spectrum Analyzer

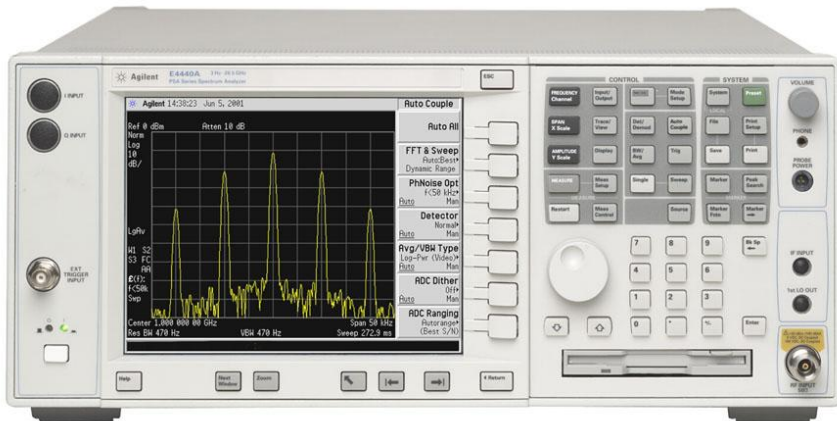

Recognize Amplifier Stability Issues

- Oscilloscope - Transient Domain Analysis:

- Oscillations or Ringing
- Overshoots
- Unstable DC Voltages
- High Distortion

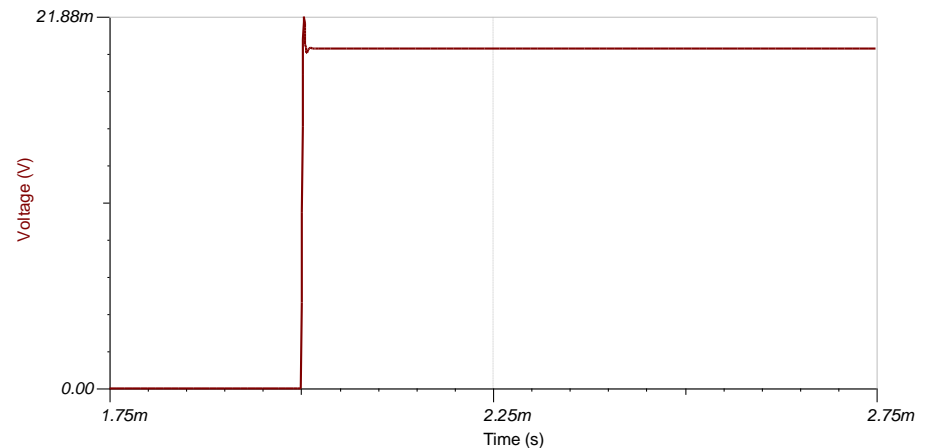
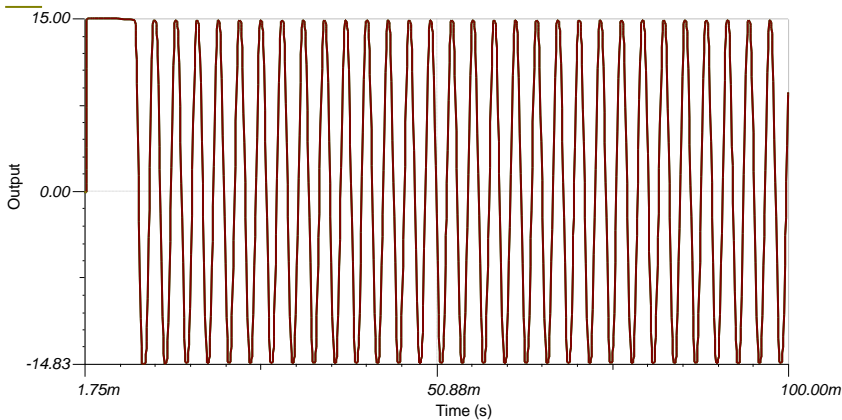
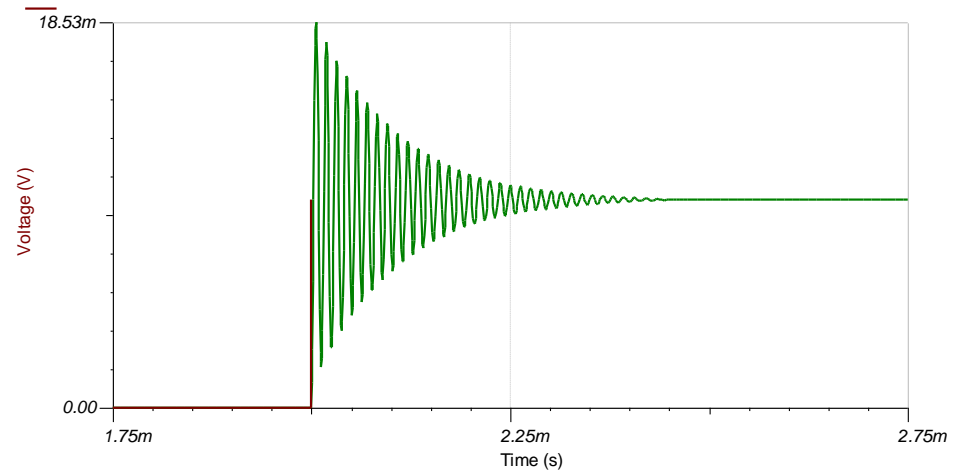

Recognize Amplifier Stability Issues

- Gain / Phase Analyzer - Frequency Domain: Peaking, Unexpected Gains, Rapid Phase Shifts

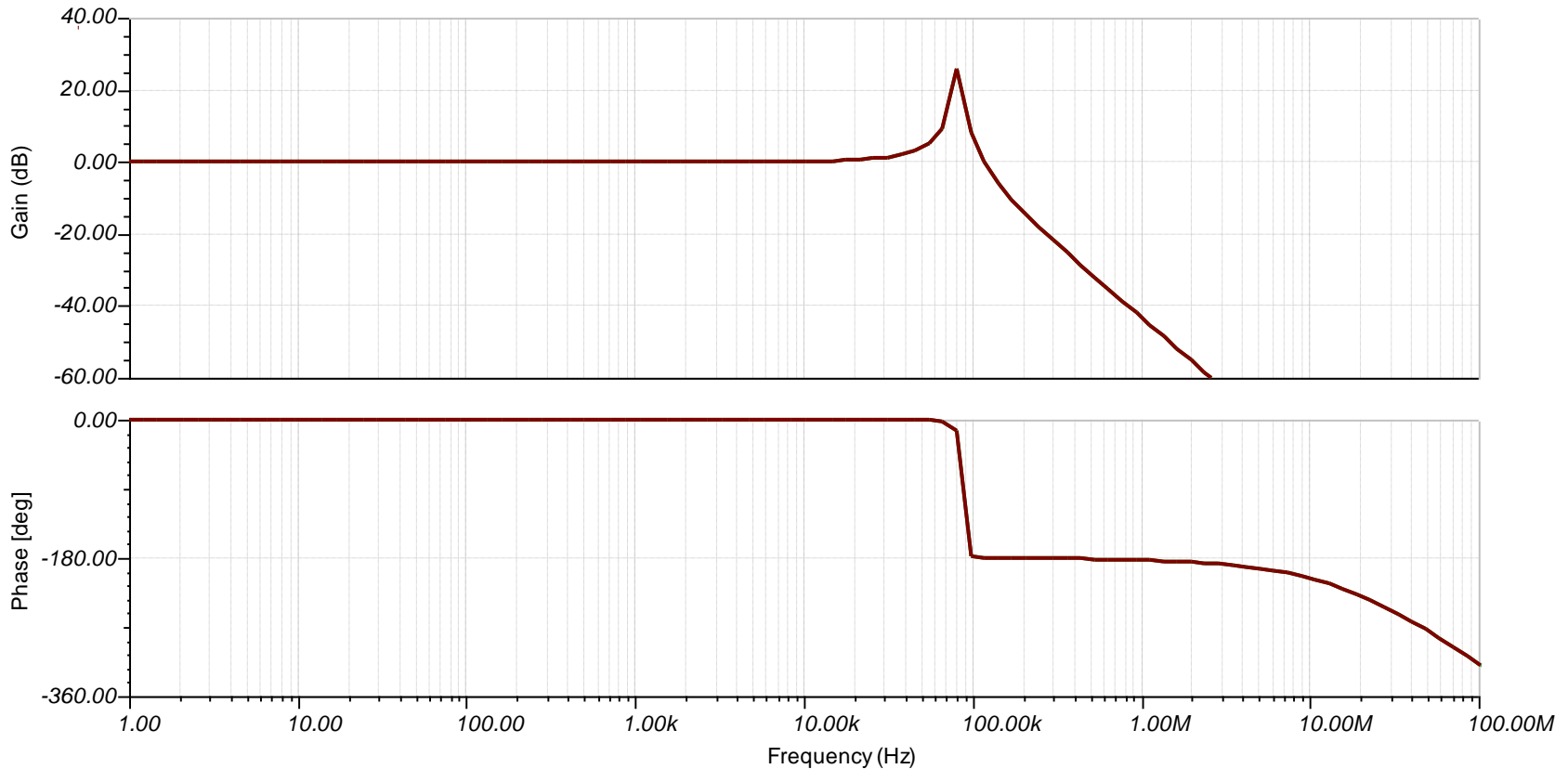

Quick Op-Amp Theory and Bode Plot Review

Poles and Bode Plots

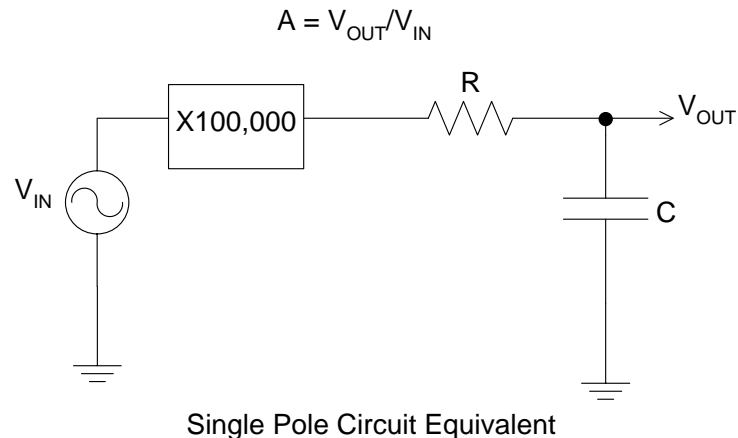
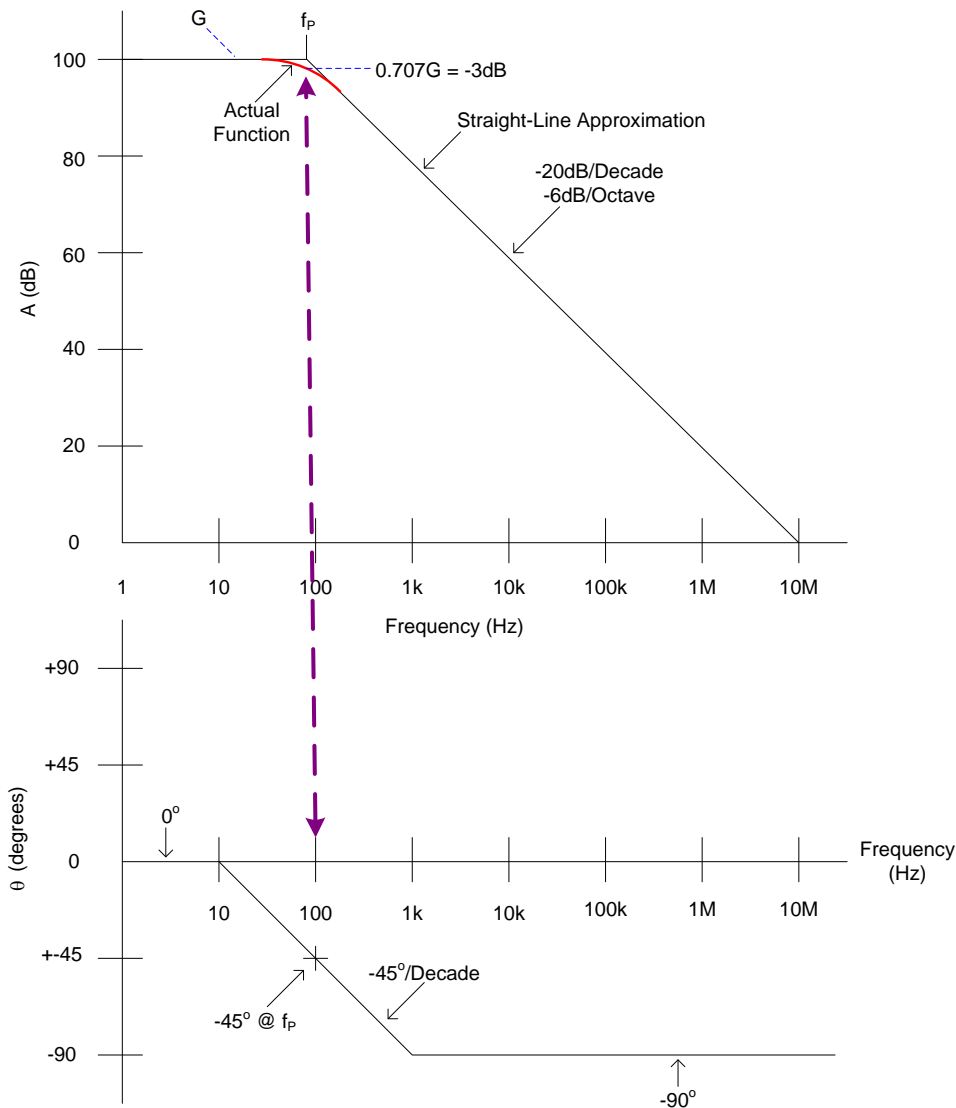

- **Pole Location** = f_p
- **Magnitude** = -20dB/Decade Slope
 - Slope begins at f_p and continues down as frequency increases
 - Actual Function = -3dB down @ f_p
- **Phase** = -45°/Decade Slope through f_p
 - Decade Above f_p Phase = -84.3°
 - Decade Below f_p Phase = -5.7°

Zeros and Bode Plots

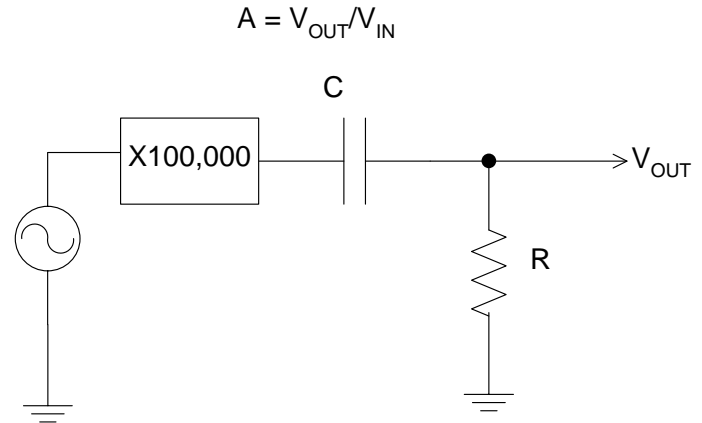
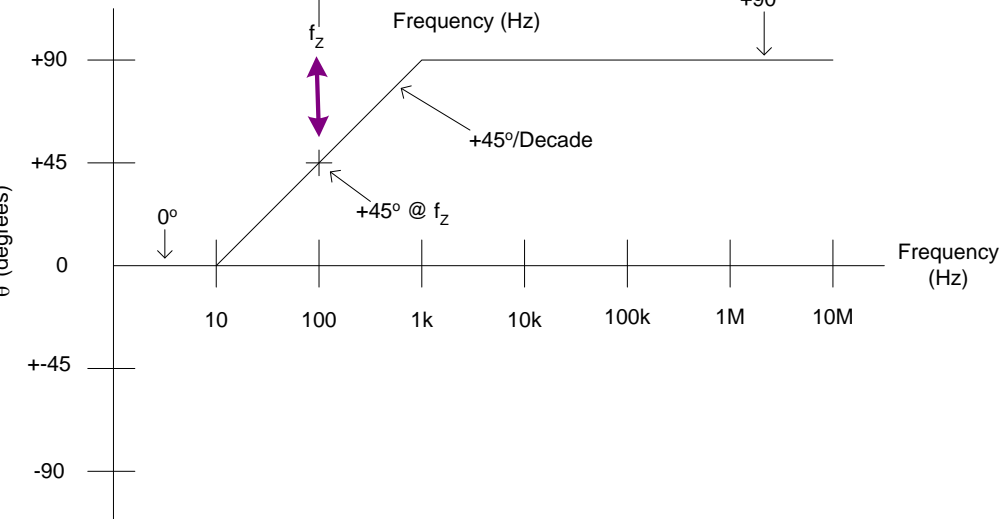
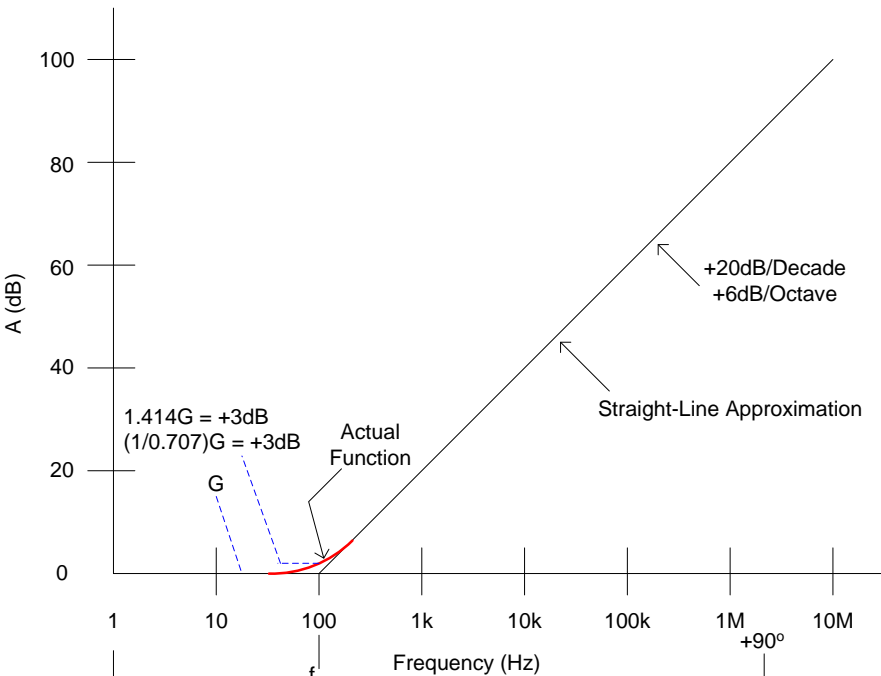

Single Zero Circuit Equivalent

- **Zero Location** = f_z
- **Magnitude** = $+20\text{dB/Decade}$ Slope
 - Slope begins at f_z and continues up as frequency increases
 - Actual Function = $+3\text{dB}$ up @ f_z
- **Phase** = $+45^\circ/\text{Decade}$ Slope through f_z
 - Decade Above f_z Phase = $+84.3^\circ$
 - Decade Below f_z Phase = 5.7°

Capacitor Intuitive Model

DC X_C

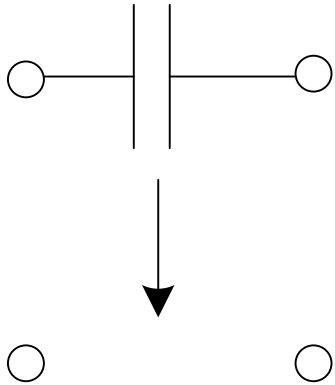

OPEN

DC $< X_C < \text{Hi-f}$

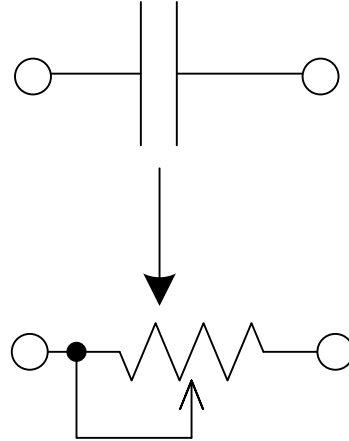

frequency
controlled
resistor

$$X_C = 1/(2\pi fC)$$

Hi-f X_C

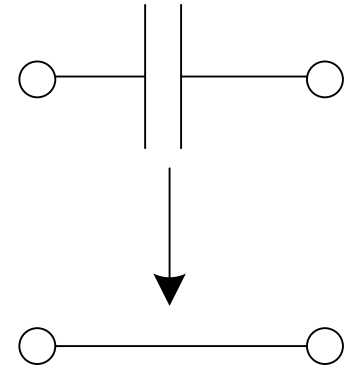

SHORT

Inductor Intuitive Model

DC X_L

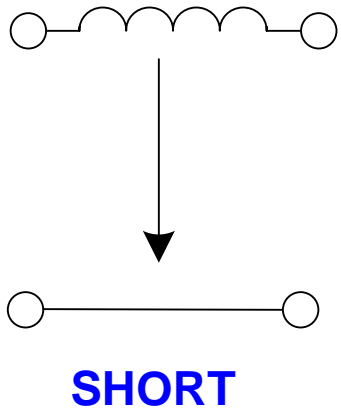

DC $< X_L <$ Hi-f

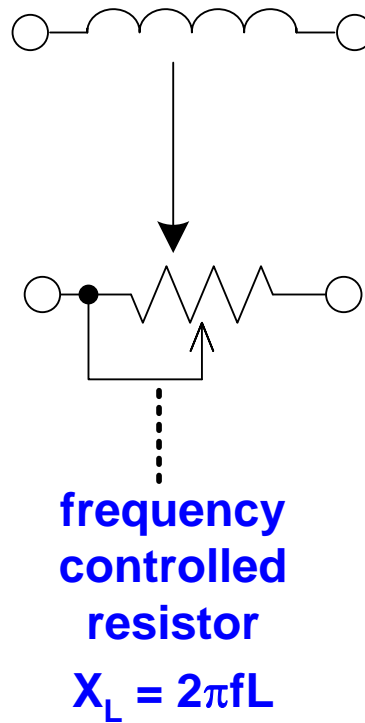

Hi-f X_L

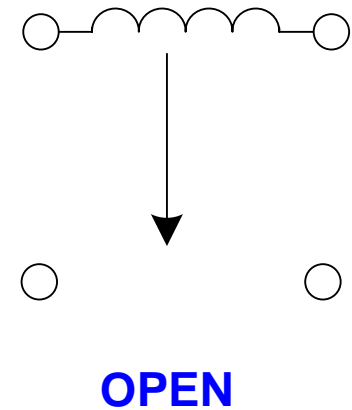

Op-Amp Intuitive Model

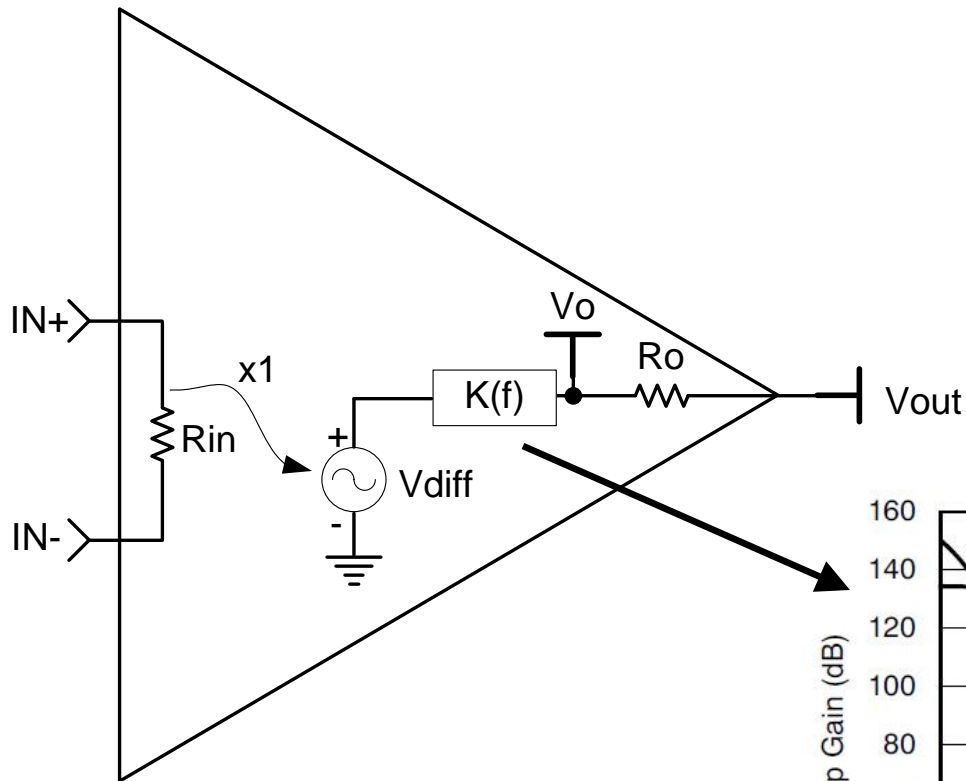

OPEN-LOOP GAIN/PHASE vs FREQUENCY

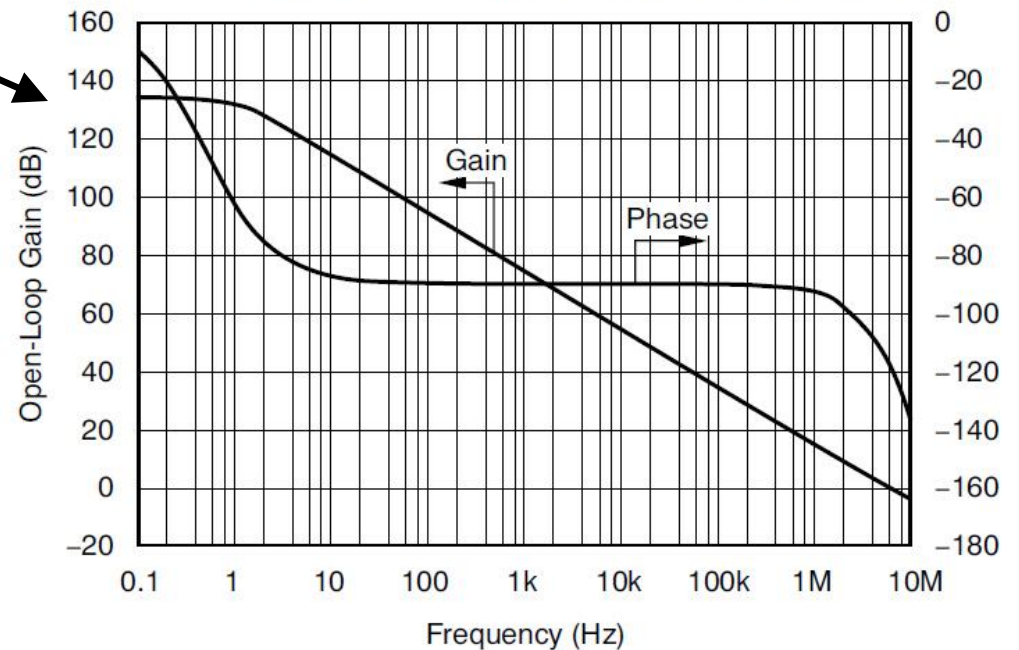

Op-Amp Loop Gain Model

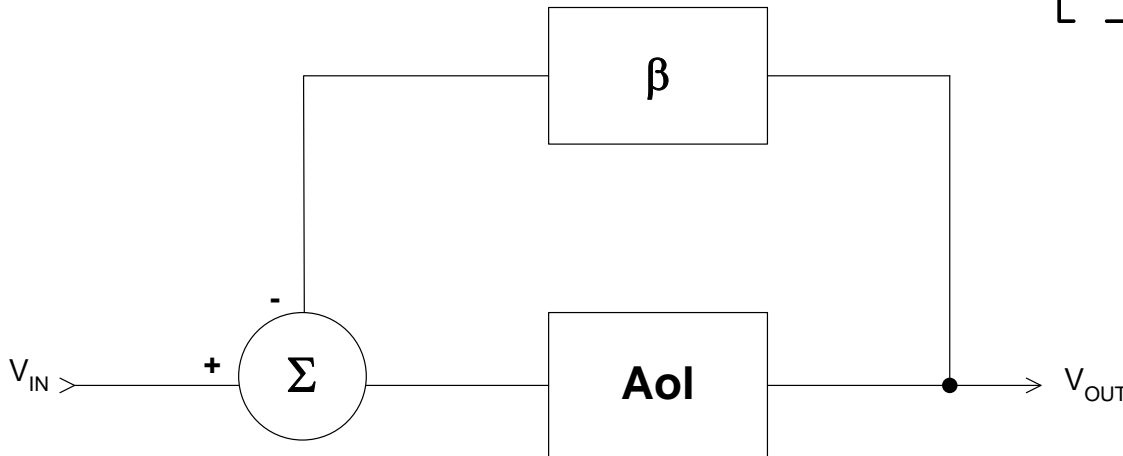
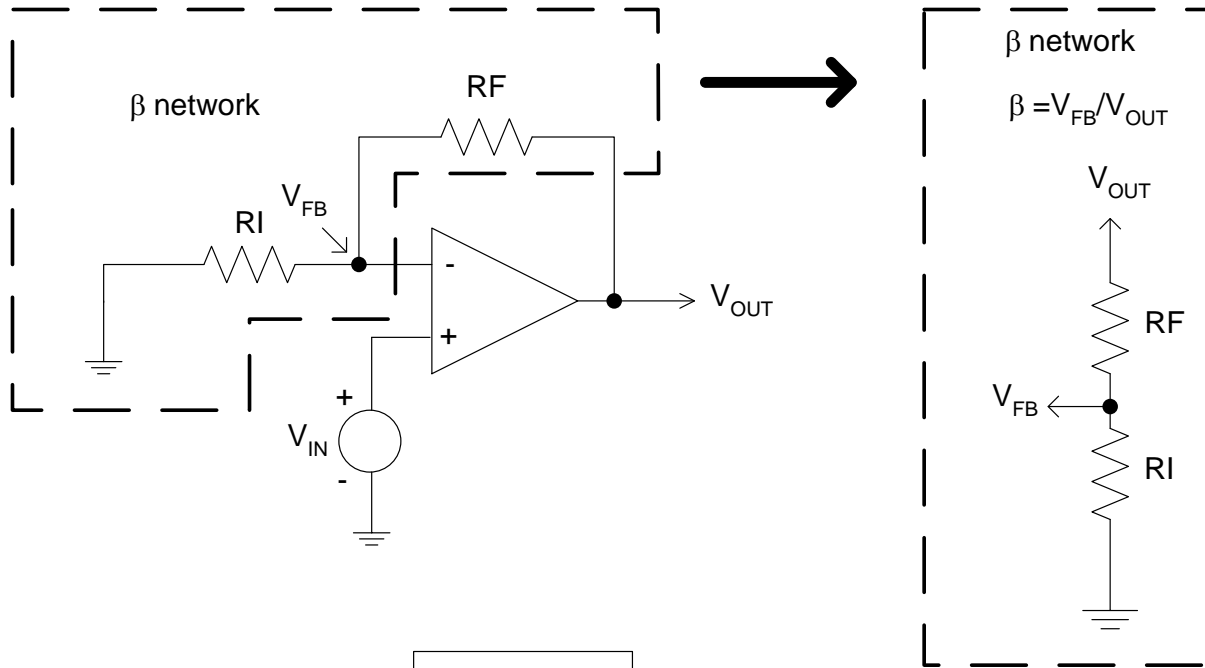

$$V_{OUT}/V_{IN} = A_{cl} = A_{ol}/(1+A_{ol}\beta)$$

If $A_{ol} \gg 1$ then $A_{cl} \approx 1/\beta$

A_{ol} : Open Loop Gain

β : Feedback Factor

A_{cl} : Closed Loop Gain

Amplifier Stability Criteria

$$V_{\text{OUT}}/V_{\text{IN}} = A_{\text{ol}} / (1 + A_{\text{ol}}\beta)$$

If: $A_{\text{ol}}\beta = -1$

Then: $V_{\text{OUT}}/V_{\text{IN}} = A_{\text{ol}} / 0 \rightarrow \infty$

If $V_{\text{OUT}}/V_{\text{IN}} = \infty \rightarrow$ Unbounded Gain

Any small changes in V_{IN} will result in large changes in V_{OUT} which will feed back to V_{IN} and result in even larger changes in $V_{\text{OUT}} \rightarrow$ **OSCILLATIONS** \rightarrow **INSTABILITY !!**

$A_{\text{ol}}\beta$: Loop Gain

$A_{\text{ol}}\beta = -1 \rightarrow$ Phase shift of $\pm 180^\circ$, Magnitude of 1 (0dB)

f_{cl}: frequency where $A_{\text{ol}}\beta = 1$ (0dB)

Stability Criteria:

At f_{cl}, where $A_{\text{ol}}\beta = 1$ (0dB), Phase Shift $< \pm 180^\circ$

Desired Phase Margin (distance from $\pm 180^\circ$ Phase Shift) $\geq 45^\circ$

What causes amplifier stability issues???

Fundamental Cause of Amplifier Stability Issues

- Too much delay in the feedback network

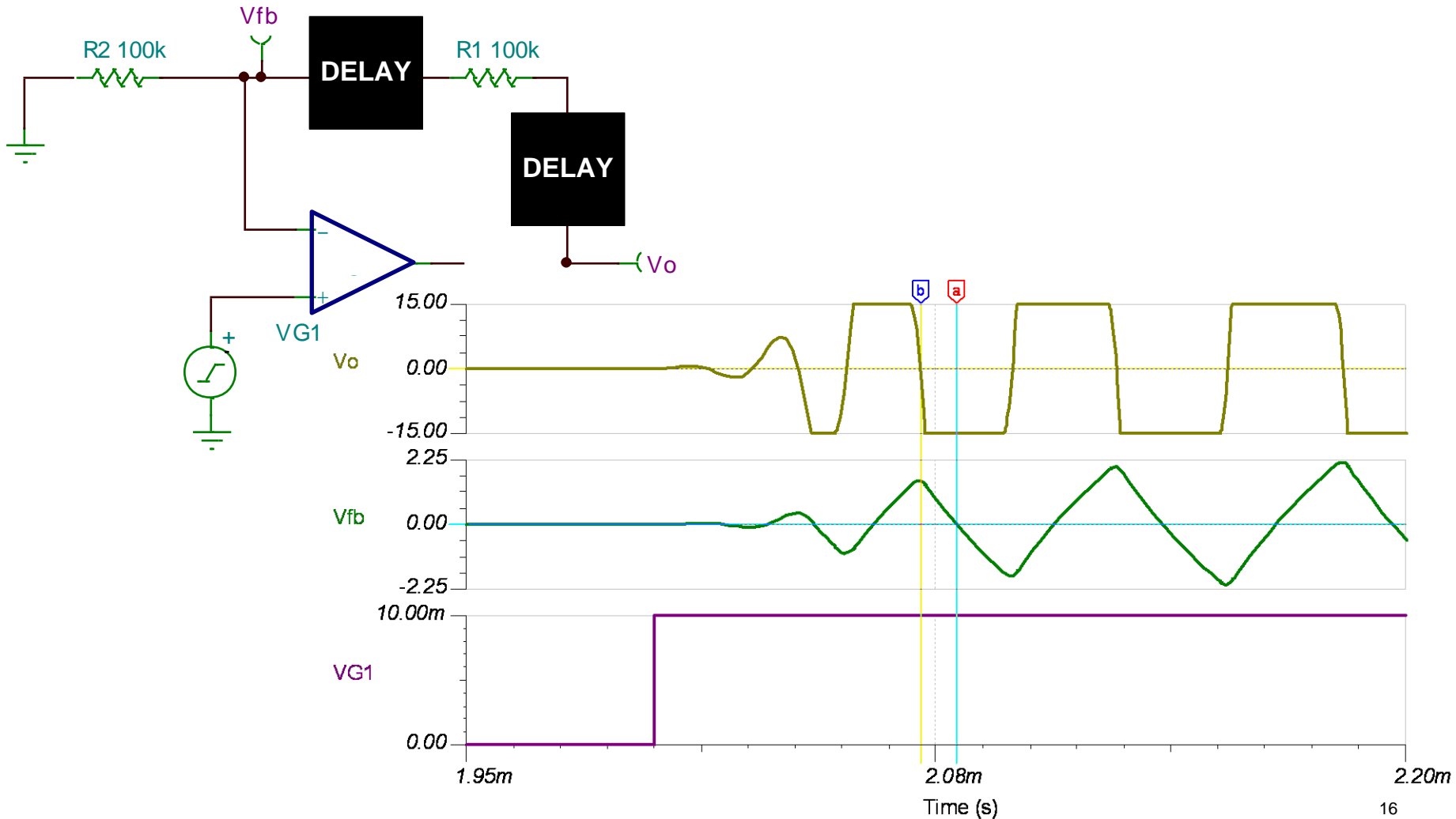

Cause of Amplifier Stability Issues

- Example circuit with too much delay in the feedback network

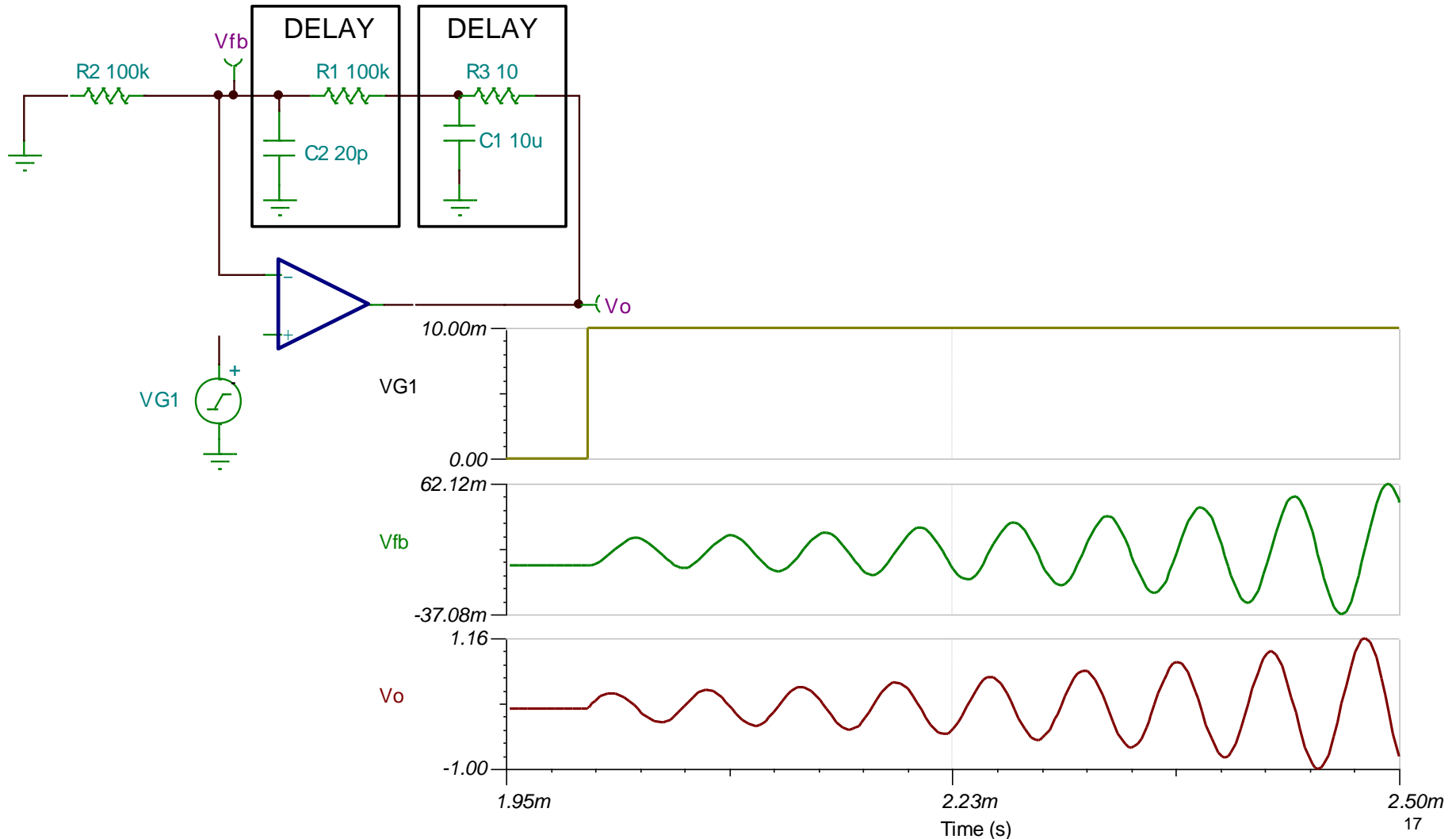

Cause of Amplifier Stability Issues

- Real circuit translation of too much delay in the feedback network

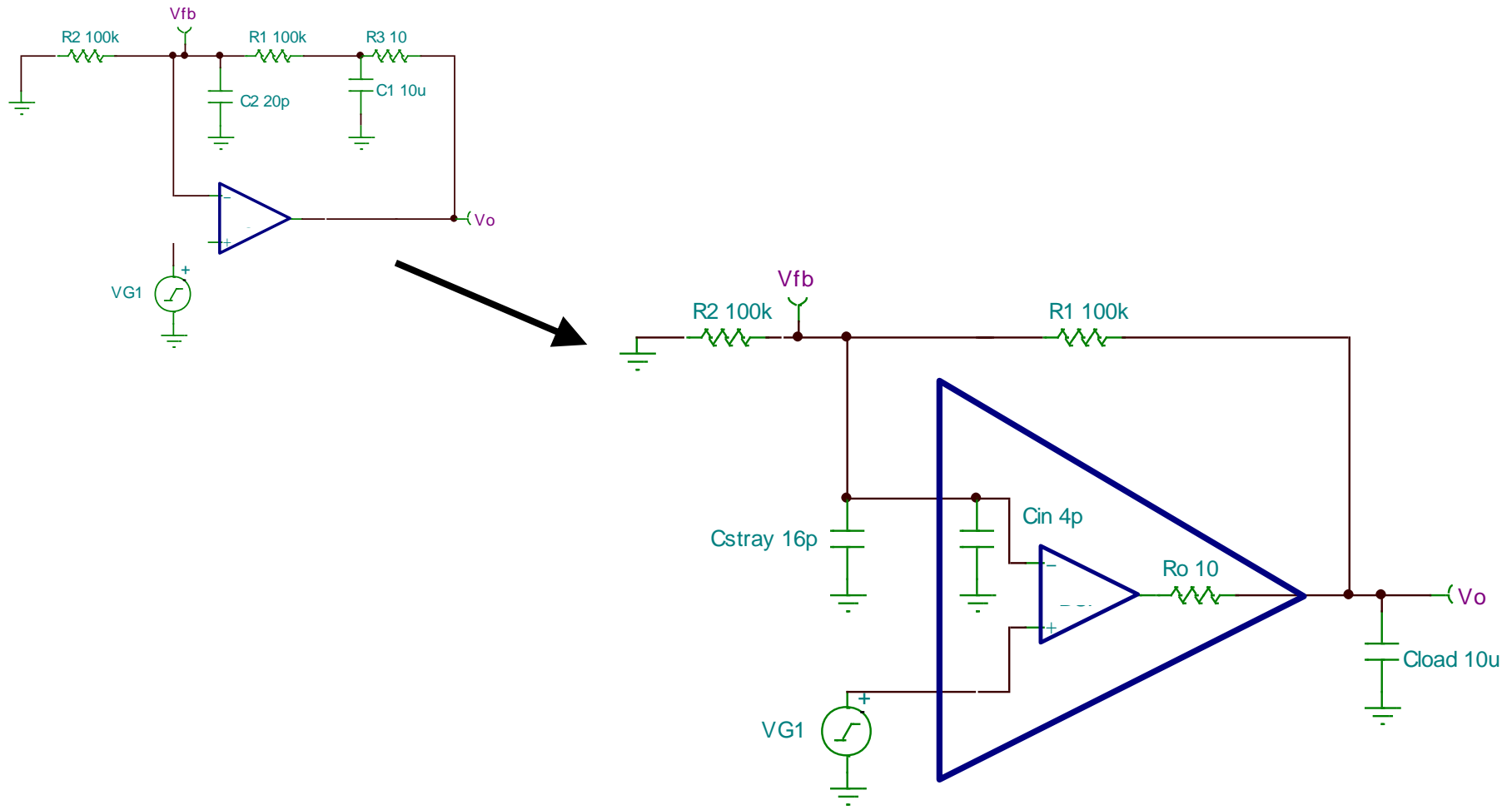

Cause of Amplifier Stability Issues

- Same results as the example circuit

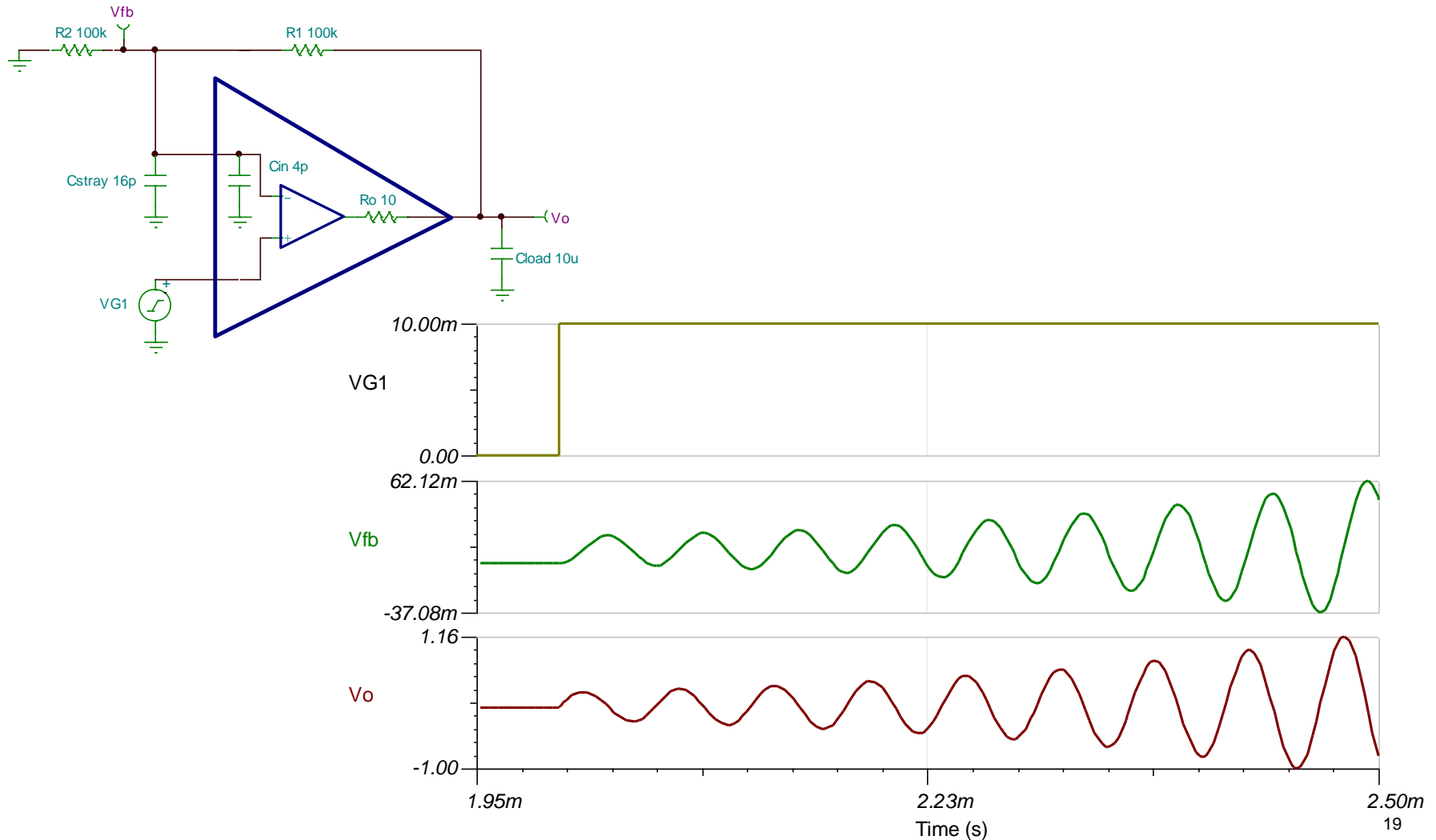

**How do we determine if
our system has too
much delay??**

Phase Margin

- Phase Margin is a measure of the “delay” in the loop

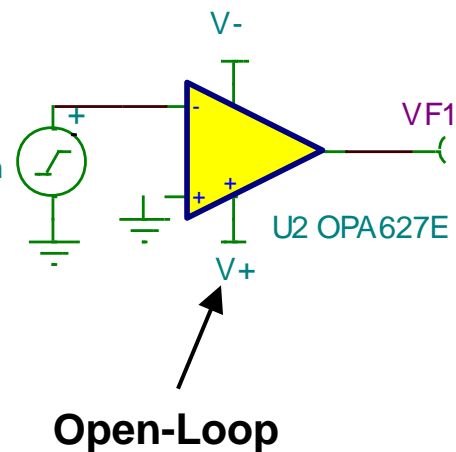
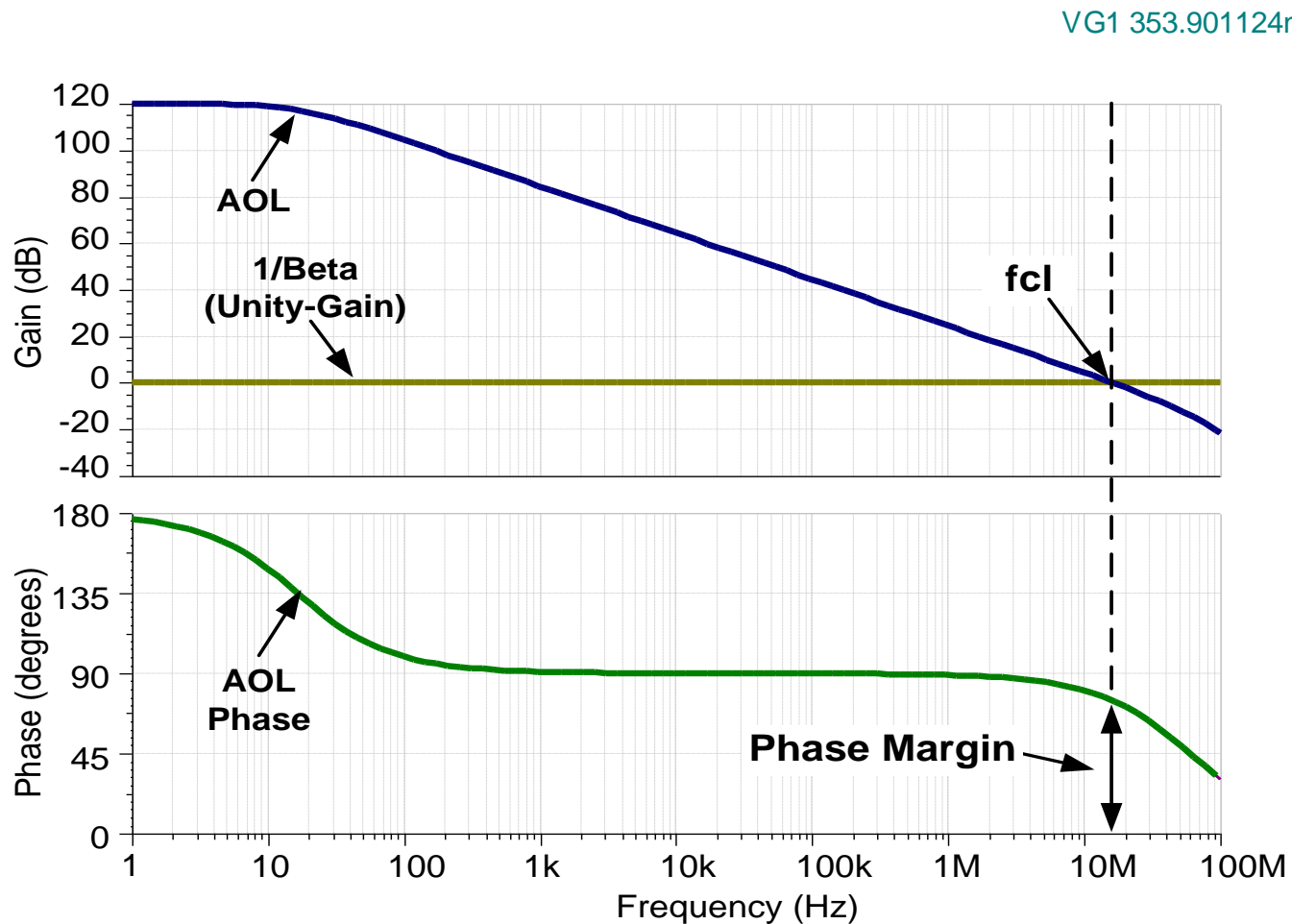

Damping Ratio vs. Phase Margin

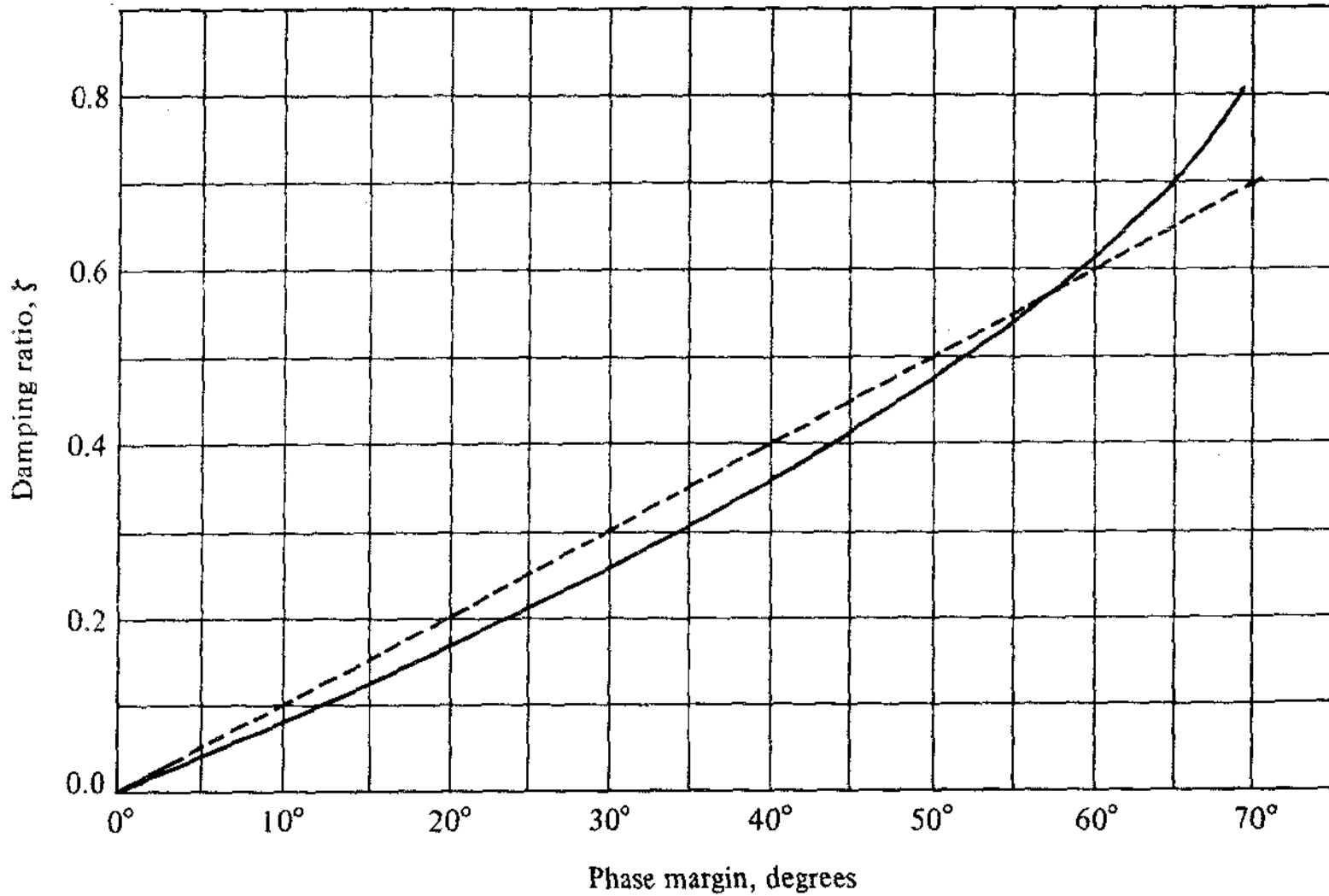

From: Dorf, Richard C. Modern Control Systems. Addison-Wesley Publishing Company. Reading, Massachusetts. Third Edition, 1981.

Small-Signal Overshoot vs. Damping Ratio

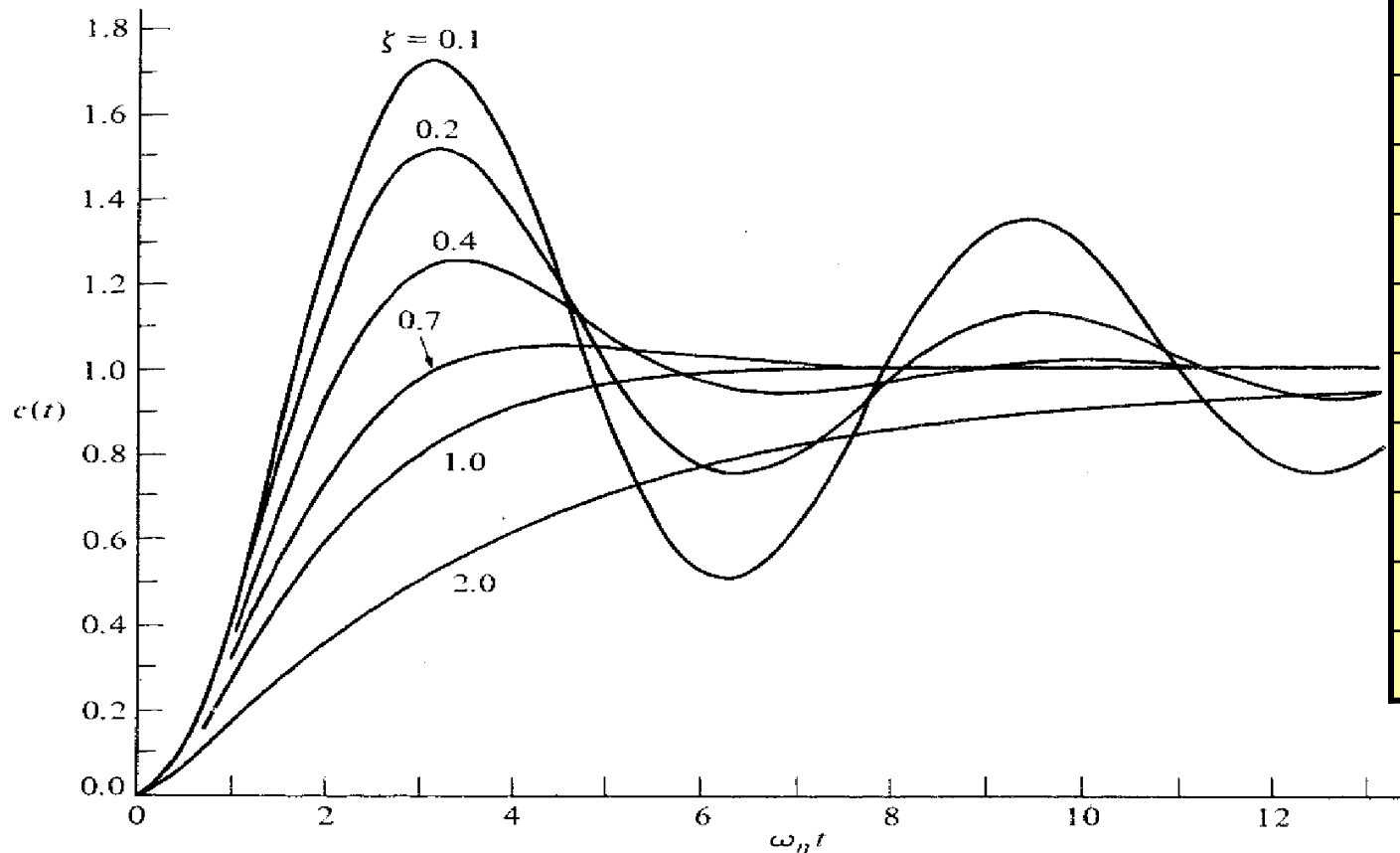

Phase Margin	Overshoot
90°	0
80°	2%
70°	5%
60°	10%
50°	16%
40°	25%
30°	37%
20°	53%
10°	73%

From: Dorf, Richard C. Modern Control Systems. Addison-Wesley Publishing Company. Reading, Massachusetts. Third Edition, 1981.

AC Peaking vs. Damping Ratio

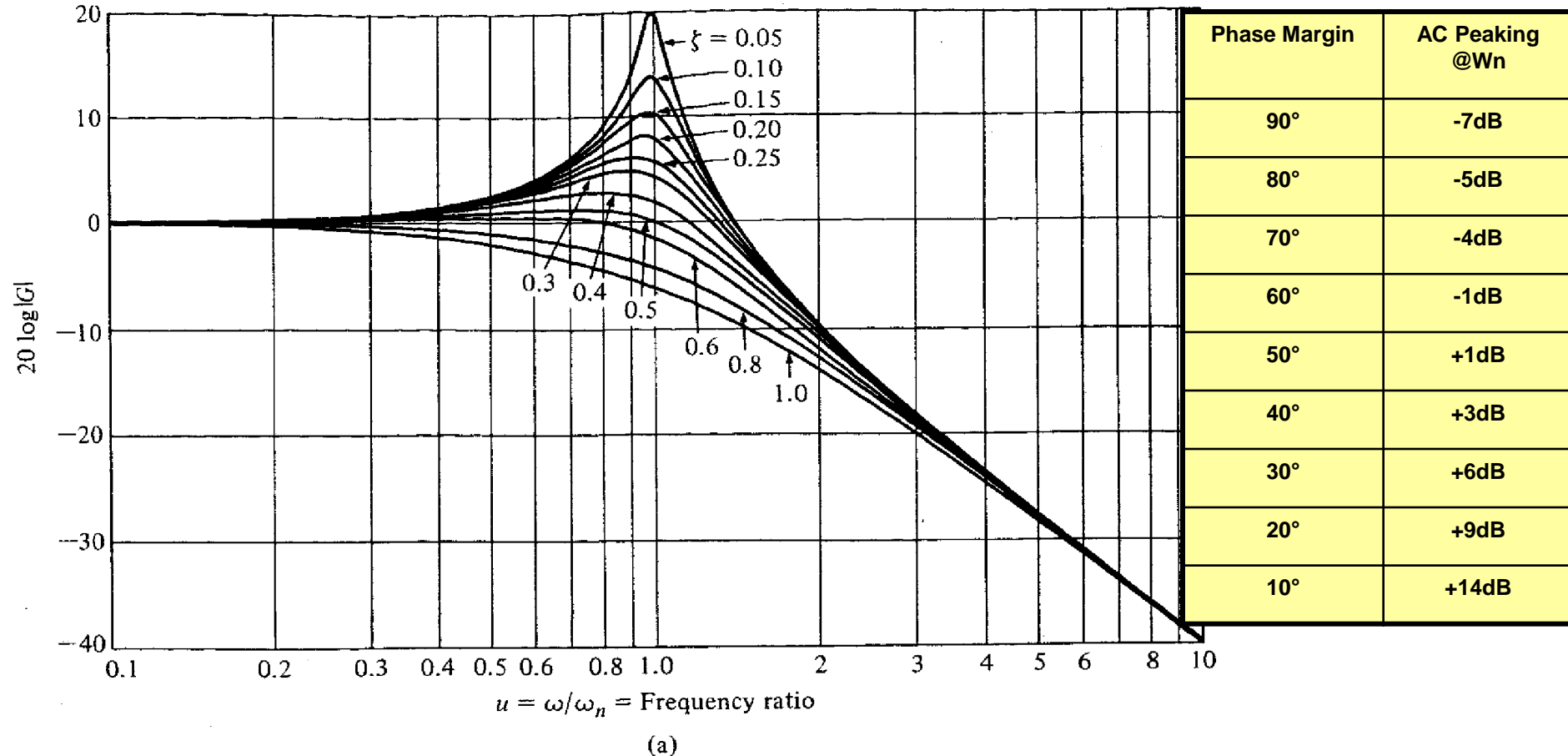

From: Dorf, Richard C. Modern Control Systems. Addison-Wesley Publishing Company. Reading, Massachusetts. Third Edition, 1981.

Rate of Closure

Rate of Closure: Rate at which 1/Beta and AOL intersect

$$\text{ROC} = \text{Slope}(1/\text{Beta}) - \text{Slope}(\text{AOL})$$

$$\text{ROC} = 0\text{dB/decade} - (-20\text{dB/decade}) = 20\text{dB/decade}$$

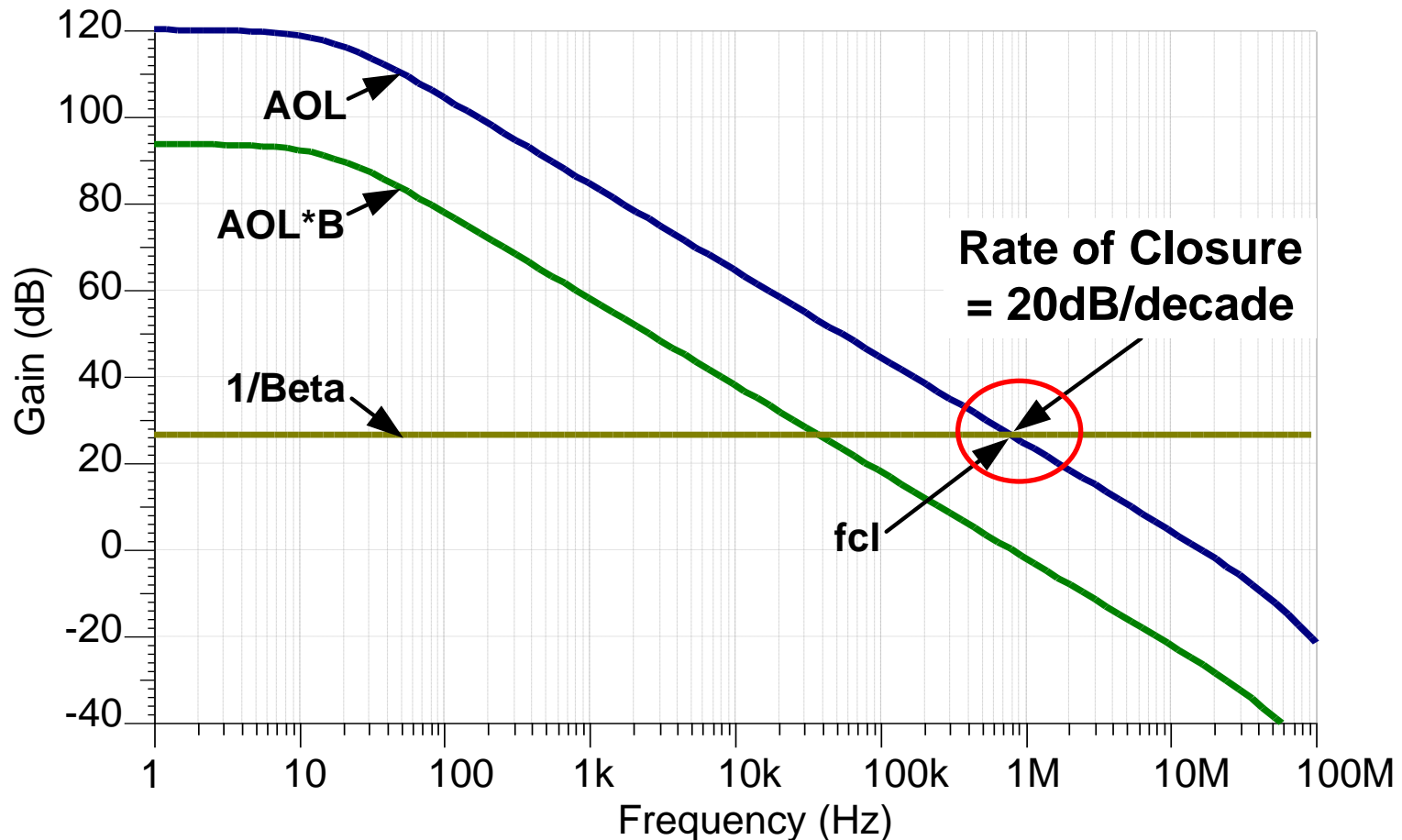

Rate of Closure and Phase Margin

Relationship between the AOL and 1/Beta rate of closure and Loop-Gain (AOL*B) phase margin

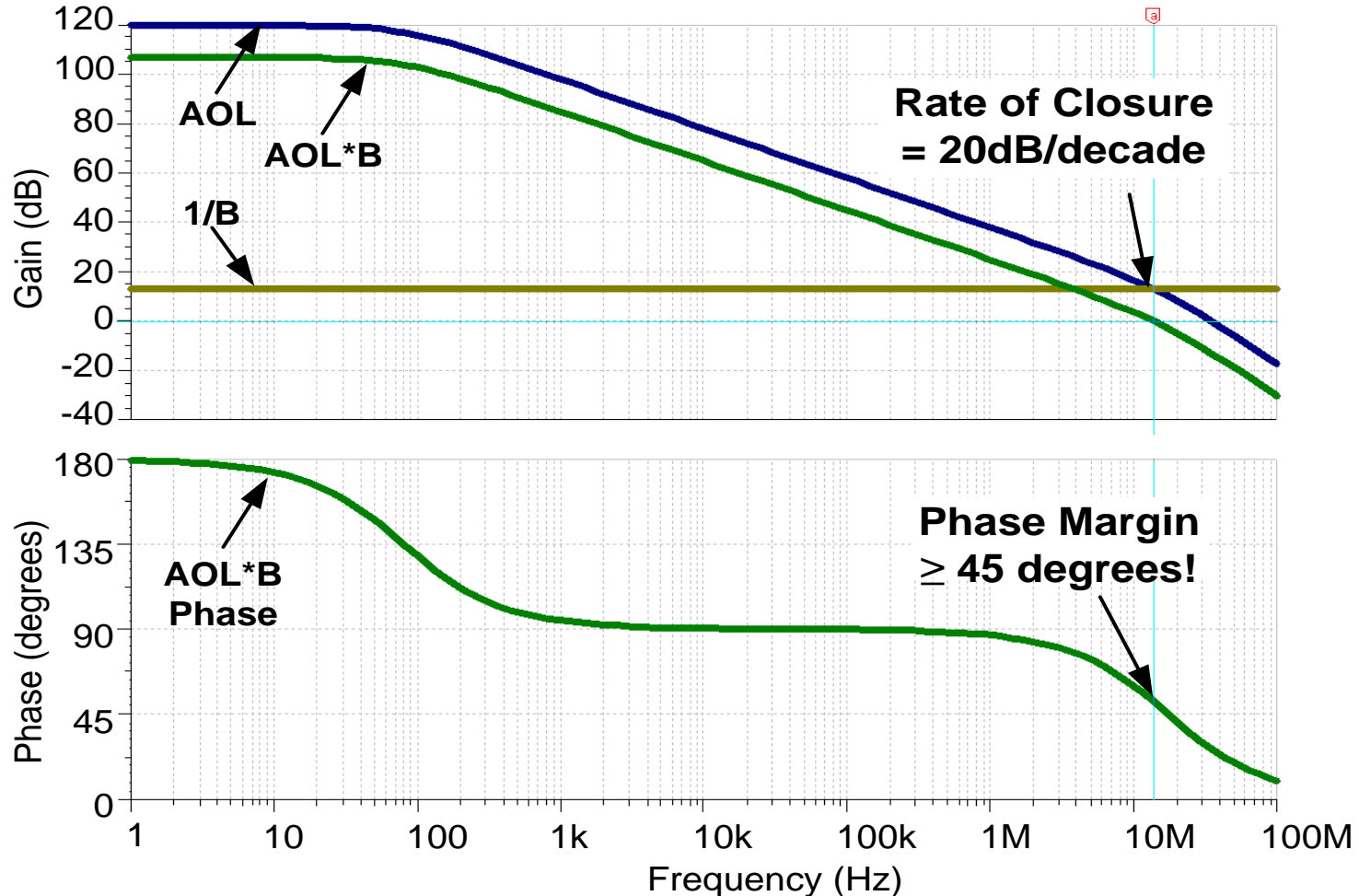

Rate of Closure and Phase Margin

So a pole in AOL or a zero in 1/Beta inside the loop will decrease AOL*B Phase!!

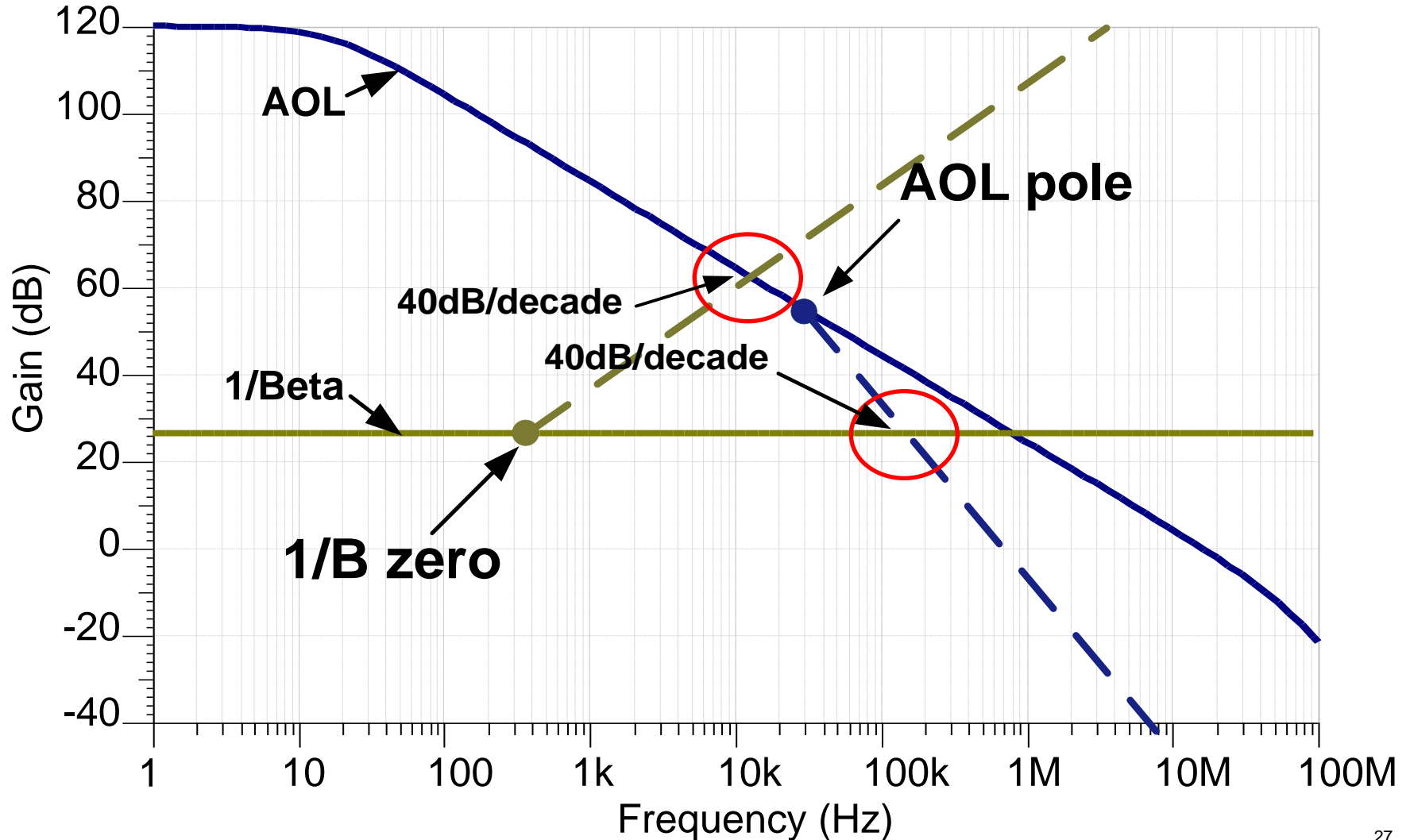

Rate of Closure and Phase Margin

AOL Pole

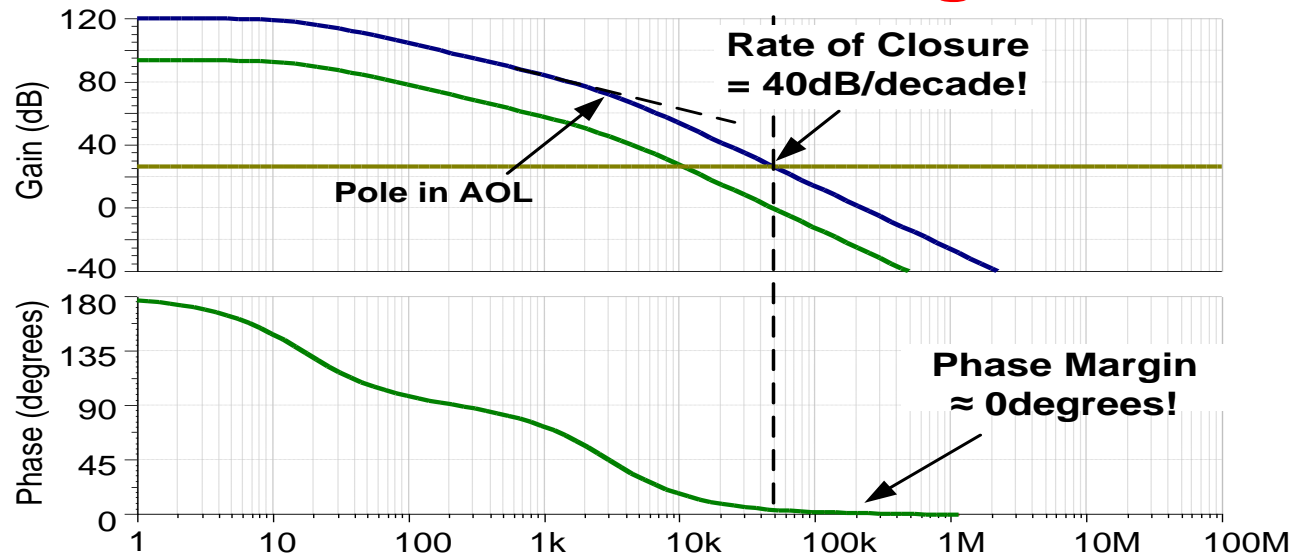

1/Beta Zero

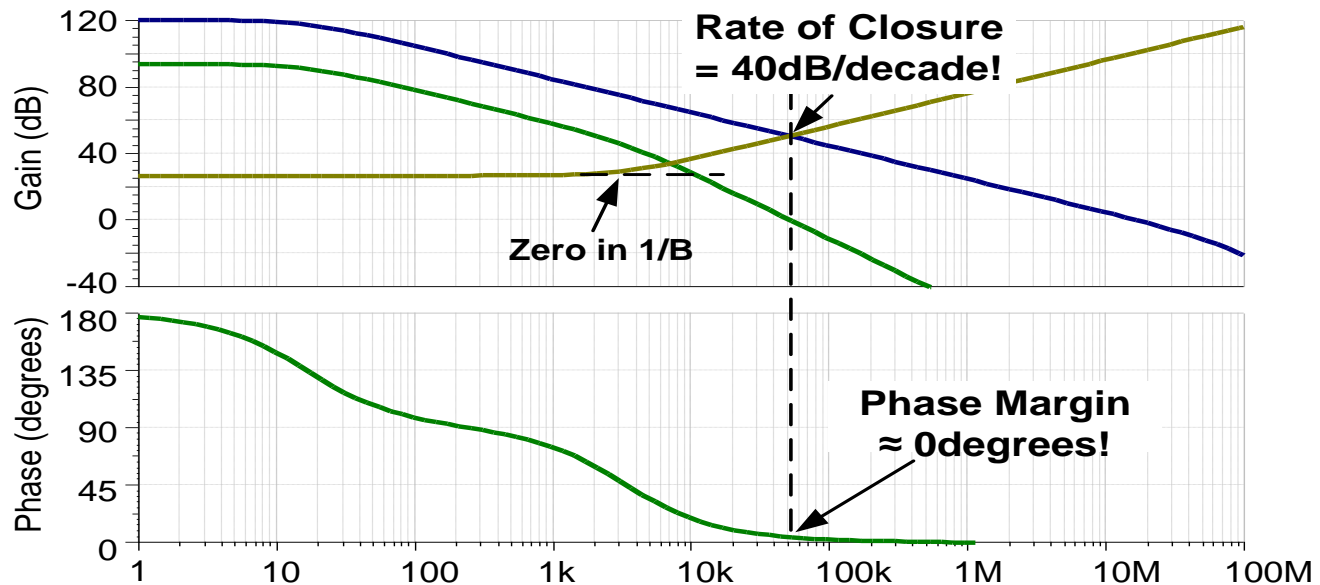

Testing for Rate of Closure in SPICE

- Break the feedback loop and inject a small AC signal

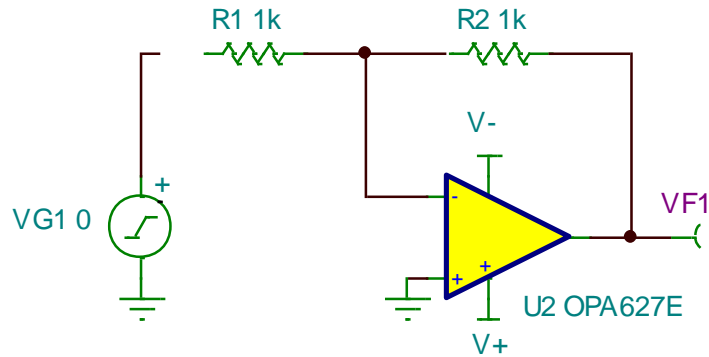

Short out the input source

Break the loop with L1 at the inverting input

Inject an AC stimulus through C1

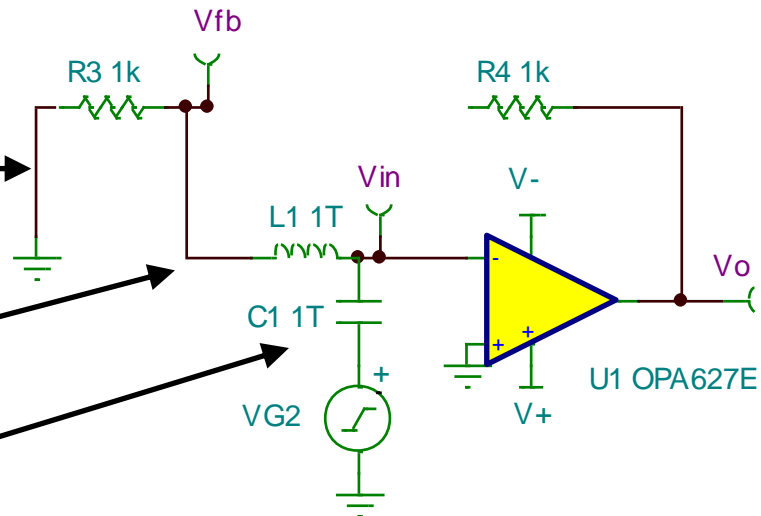

Breaking the Loop

DC

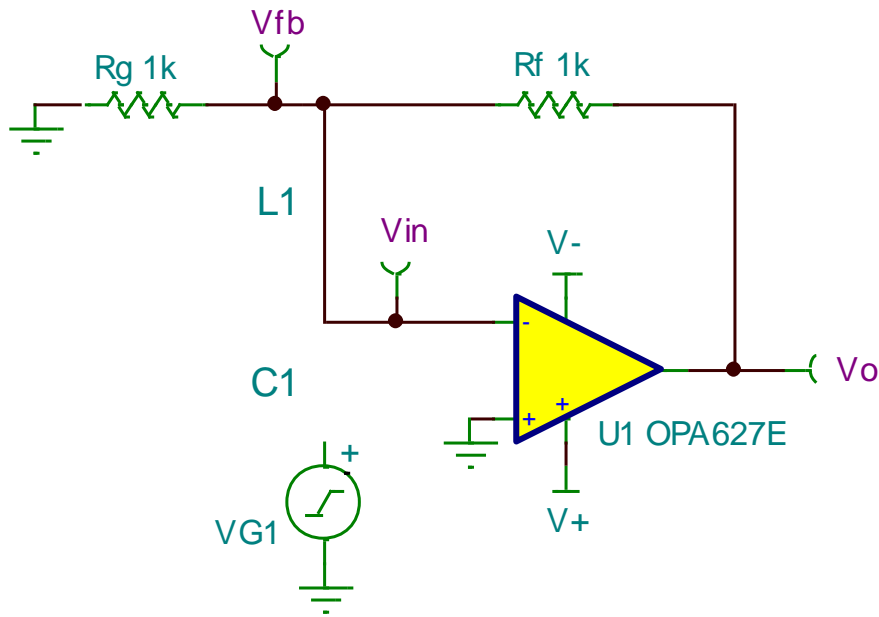

AC

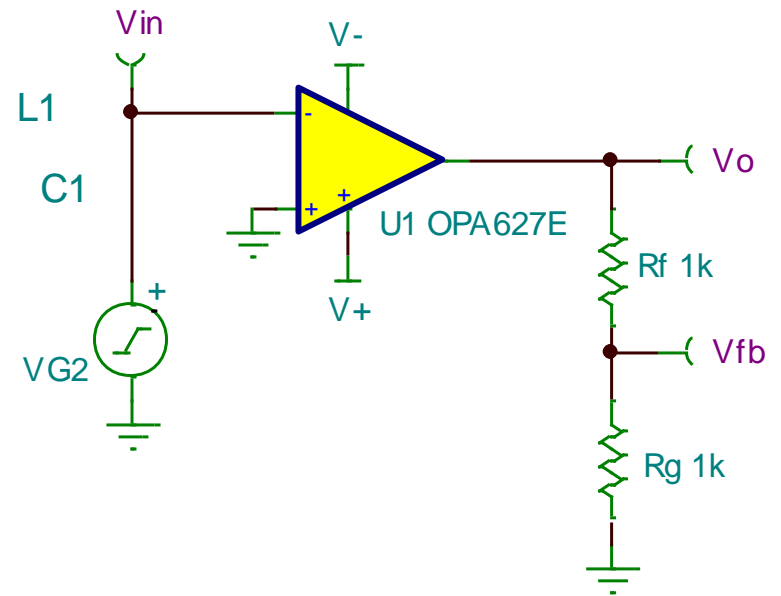

Plotting AOL, 1/Beta, and Loop Gain

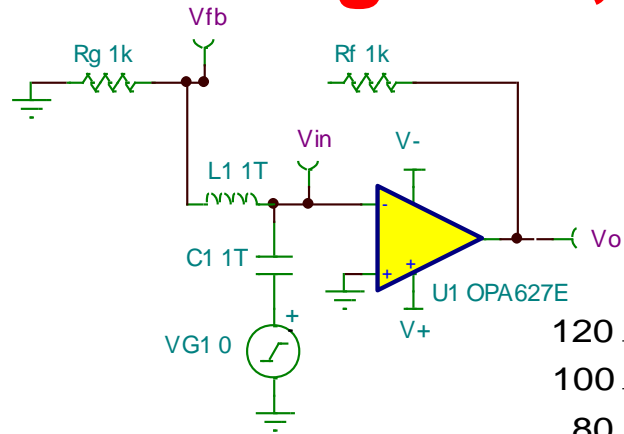

$$\text{AOL} = V_o/V_{in}$$

$$1/\text{Beta} = V_o/V_{fb}$$

$$\text{AOL} * \text{B} = V_{fb}/V_{in}$$

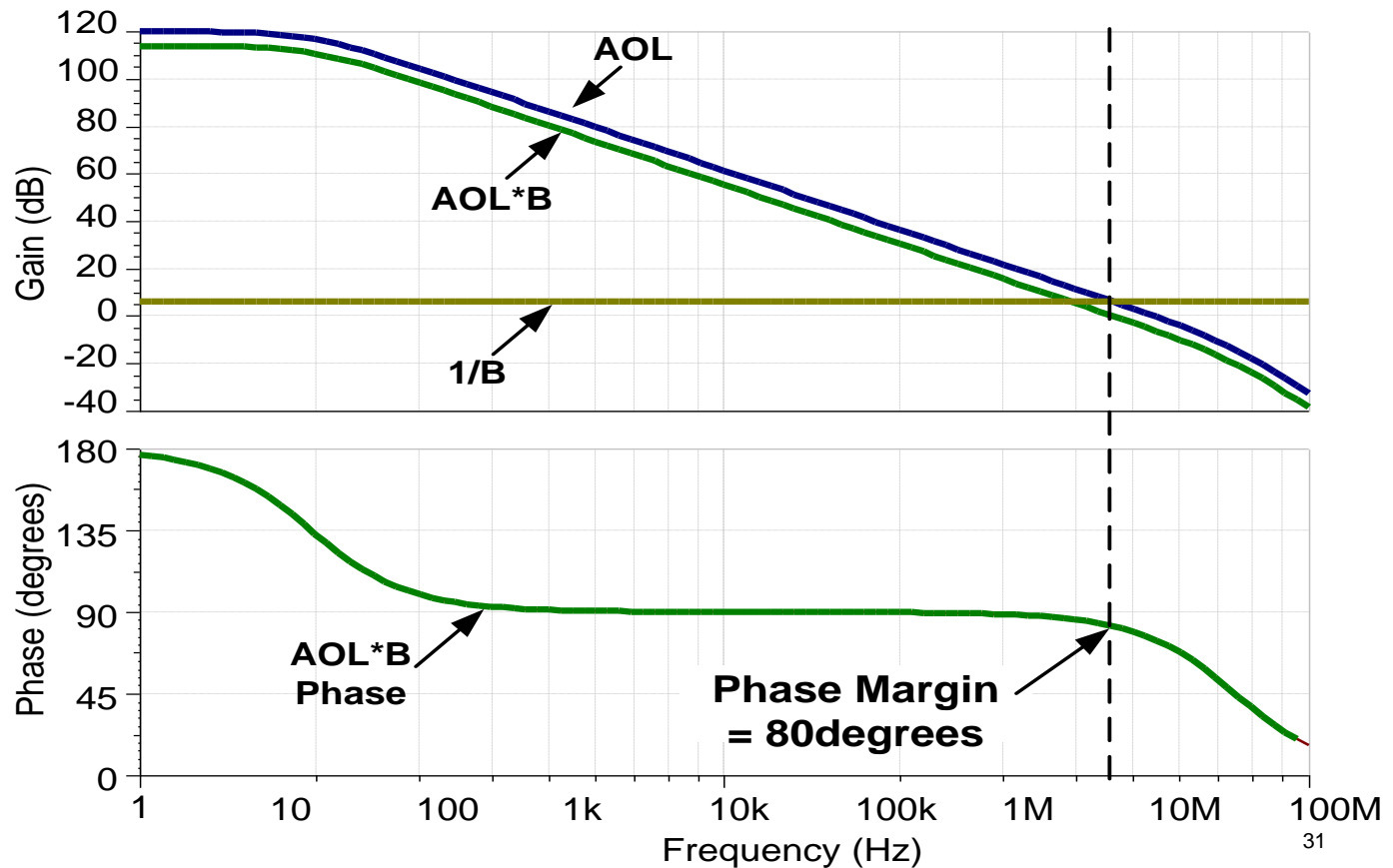

Noise Gain

- Understanding Noise Gain vs. Signal Gain

Signal Gain, $G = -1$

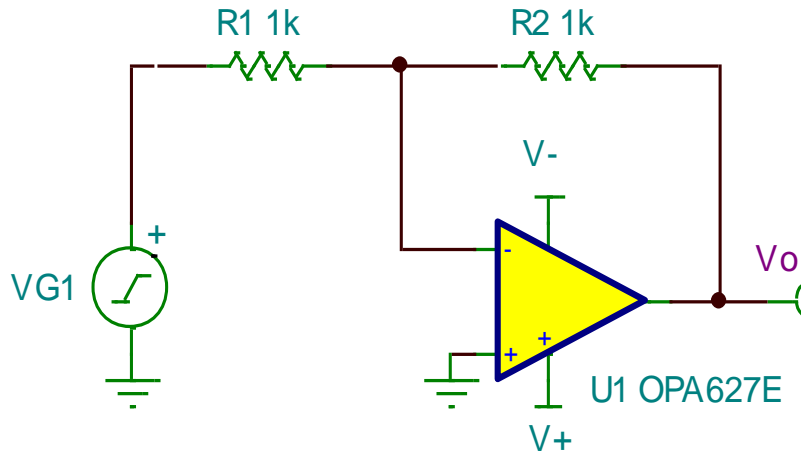

$$NG = 1 + |SG| = 2$$

Signal Gain, $G = 2$

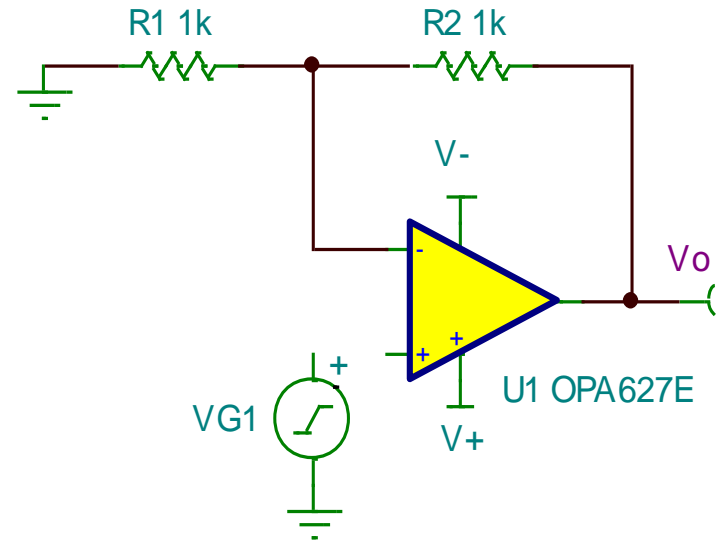

$$NG = SG = 2$$

Both circuits have a **NOISE GAIN** (NG) of 2.

Noise Gain

- Noise Gain vs. Signal Gain

Gain of -0.1V/V , Is it Stable?

Signal Gain, $G = -0.1$

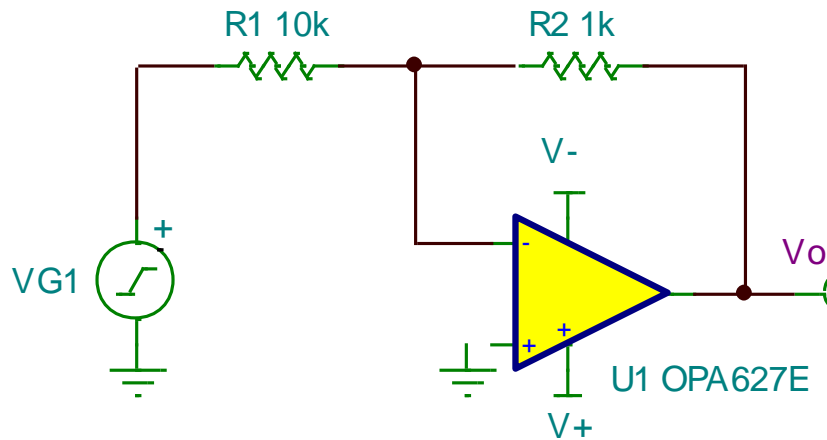

Noise Gain, $NG = 1.1$

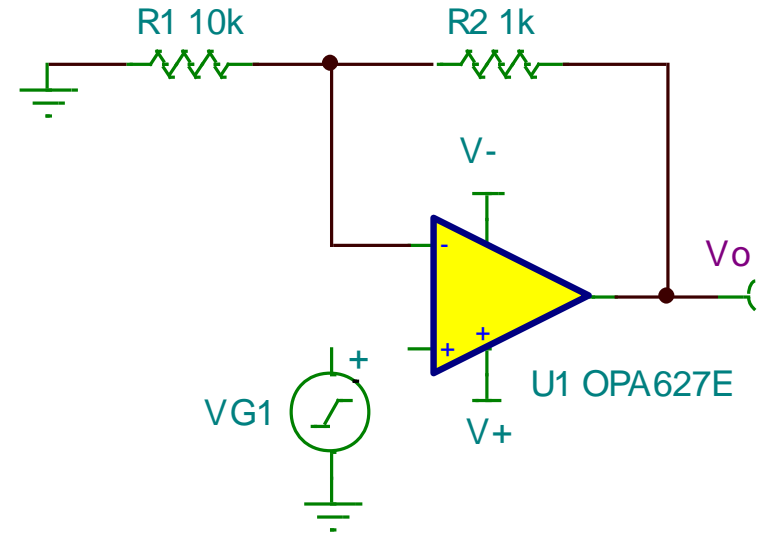

If it's unity-gain stable then it's stable as an inverting attenuator!!!

Capacitive Loads

Capacitive Loads

Unity Gain Buffer Circuits

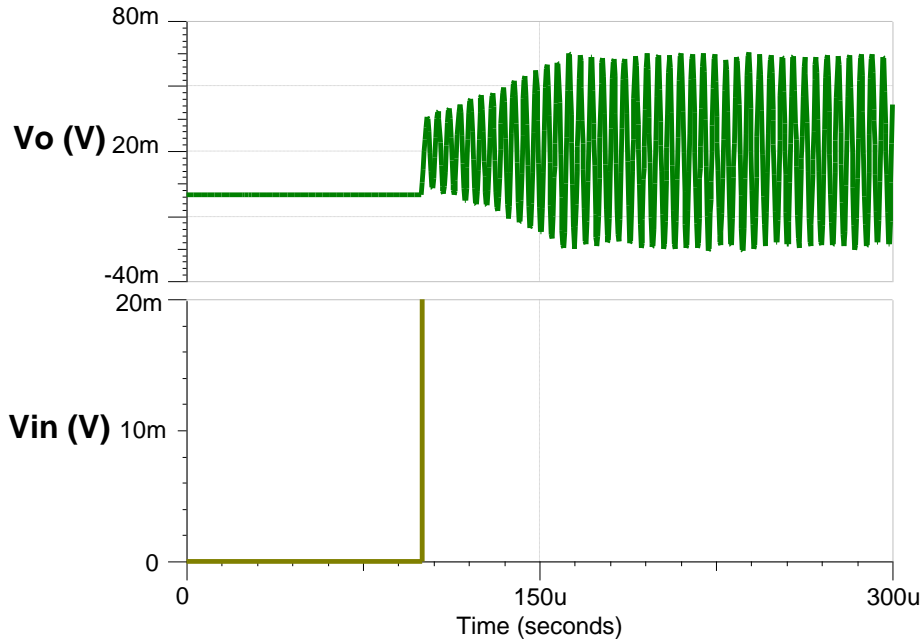
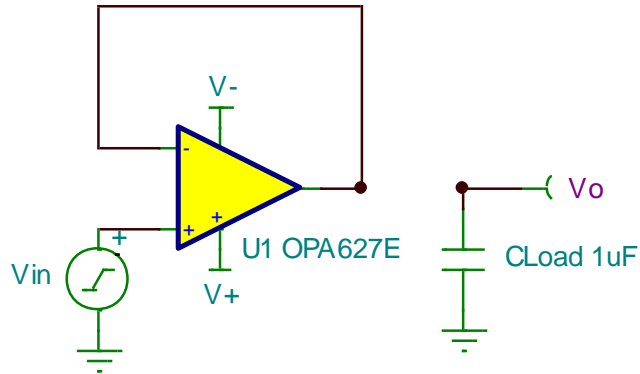

Circuits with Gain

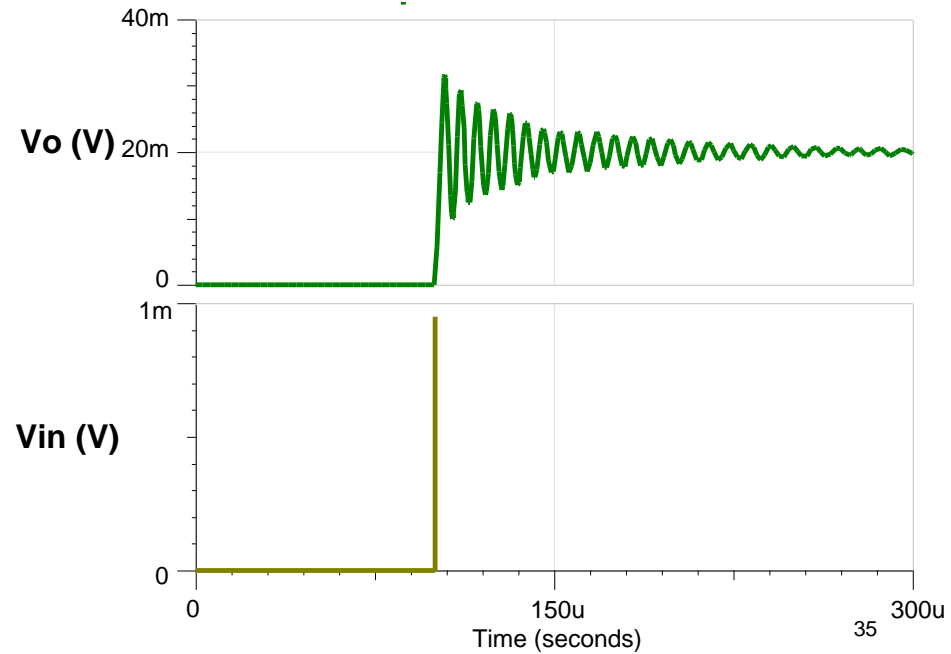
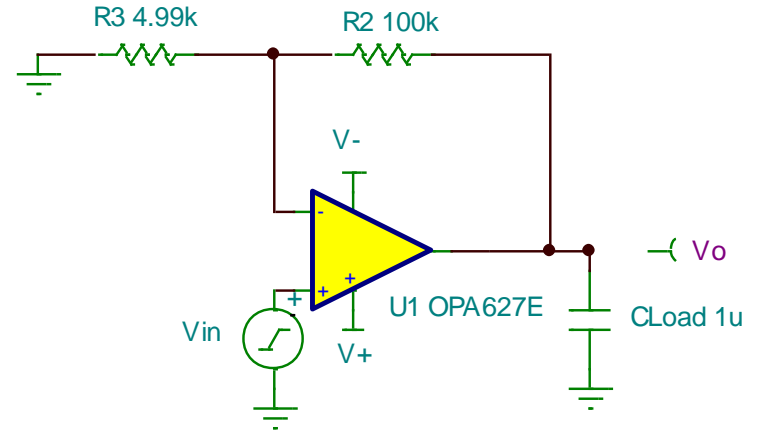

Capacitive Loads – Unity Gain Buffers - Results

Determine the issue:

Pole in AOL!!

ROC = 40dB/decade!!

Phase Margin 0!!

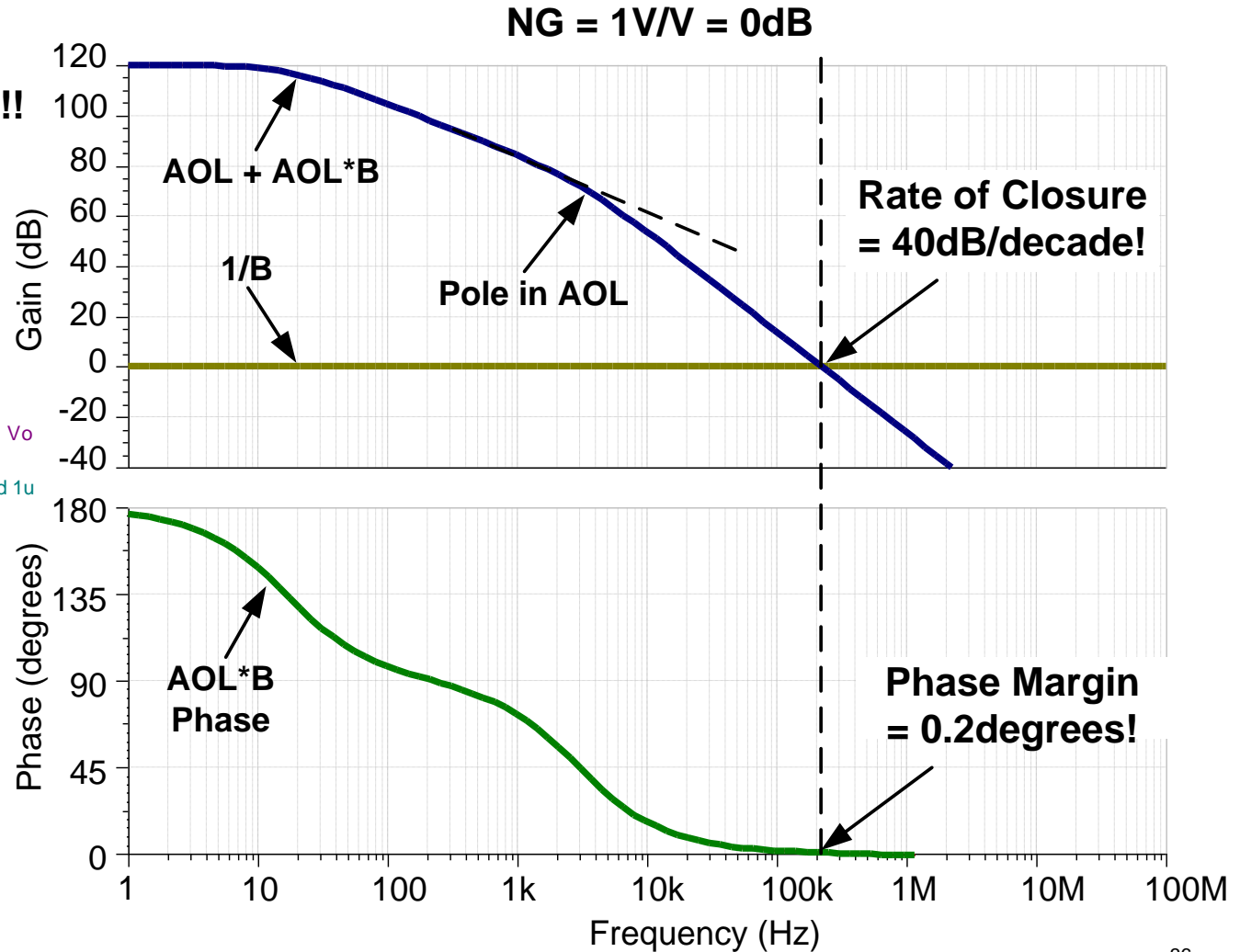
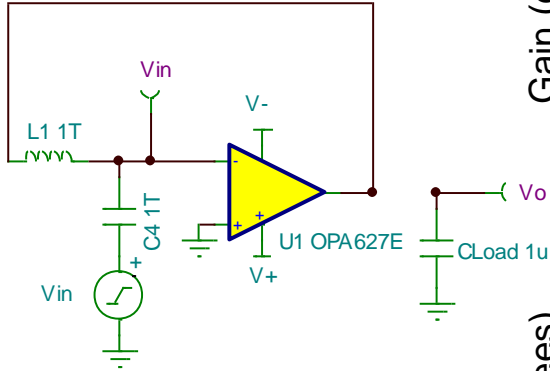

Capacitive Loads – Unity Gain Buffers - Theory

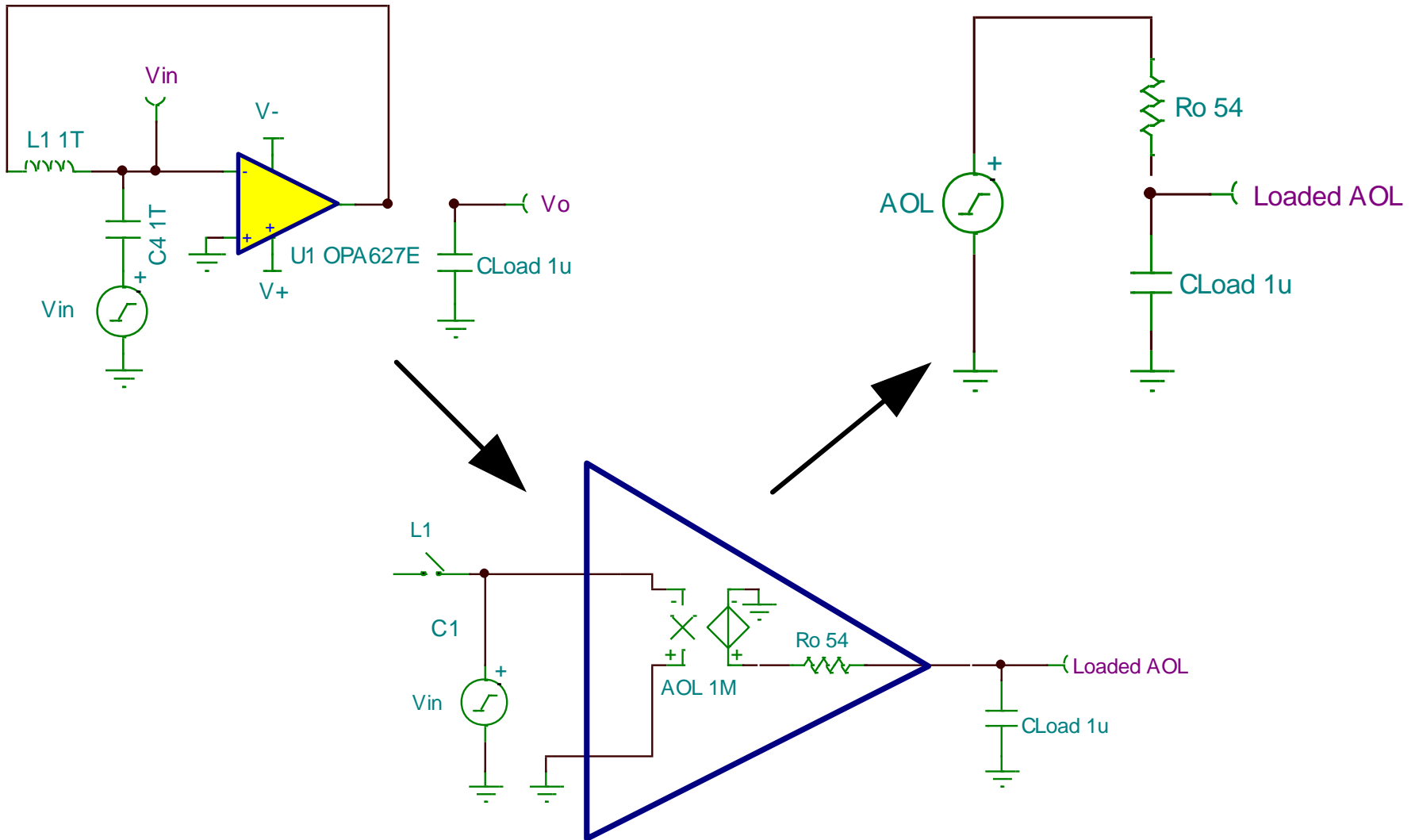

Capacitive Loads – Unity Gain Buffers - Theory

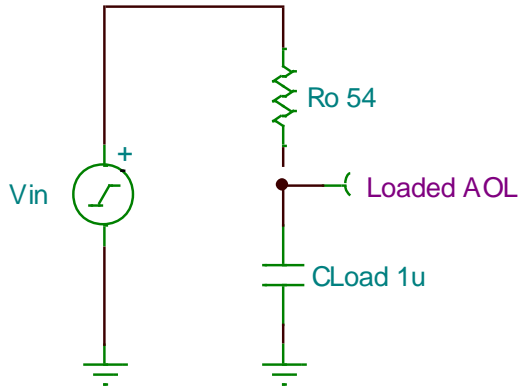

Transfer function:

$$W(s) = \frac{1}{1 + R_o \cdot C_{load} \cdot s}$$

$$f(\text{pole}) = \frac{1}{2 \cdot \pi \cdot R_o \cdot C_{Load} \cdot s}$$

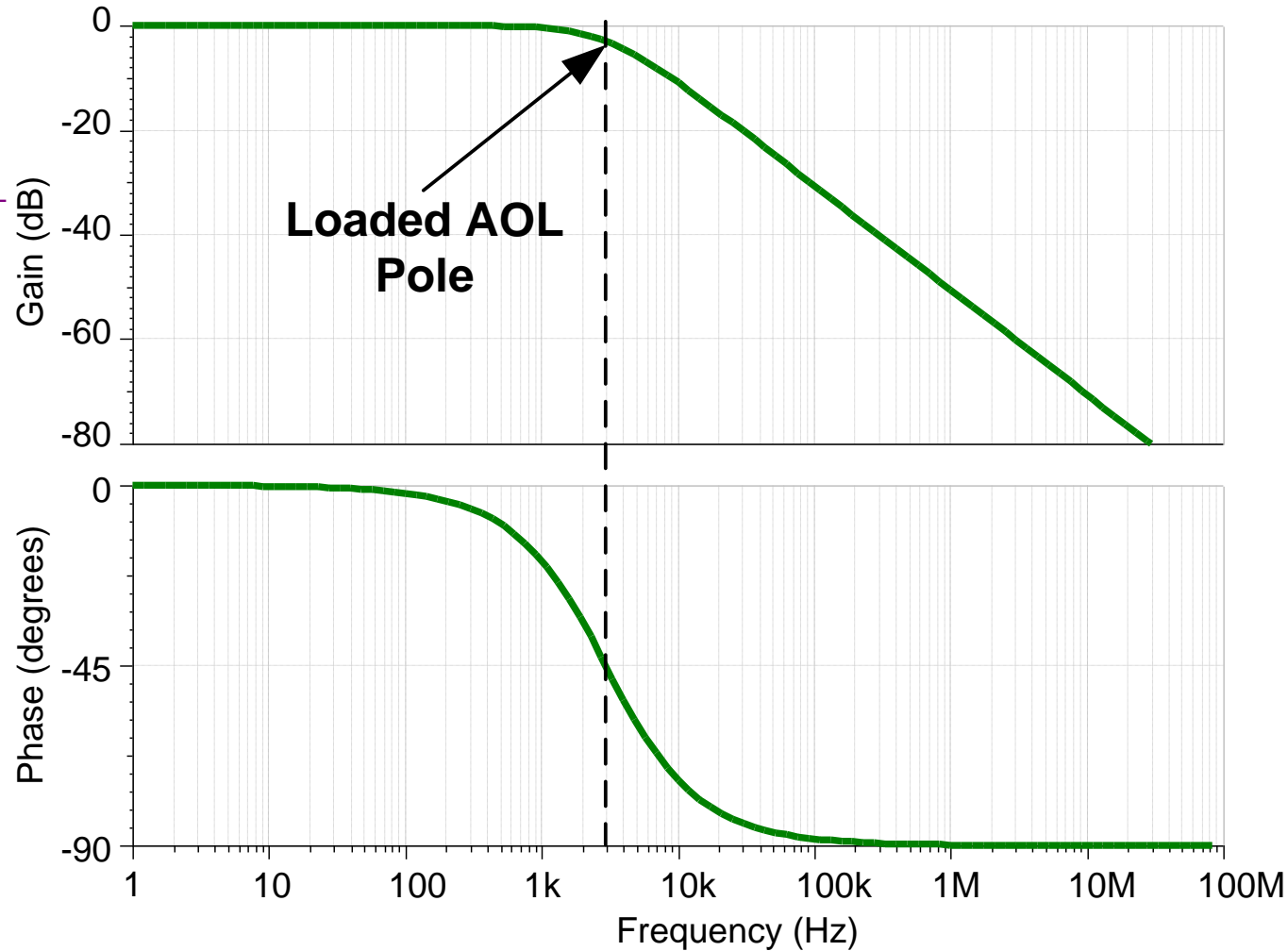

Capacitive Loads – Unity Gain Buffers - Theory

AOL

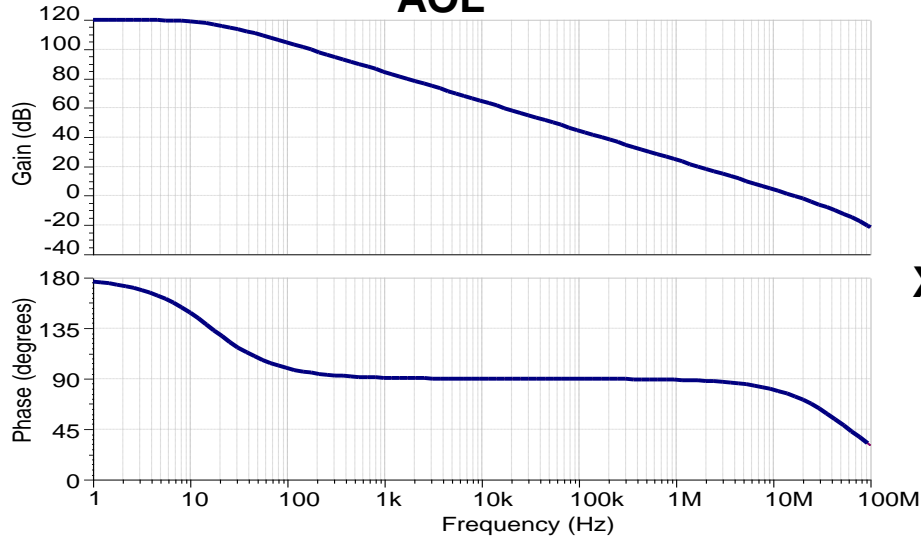

AOL Load

X

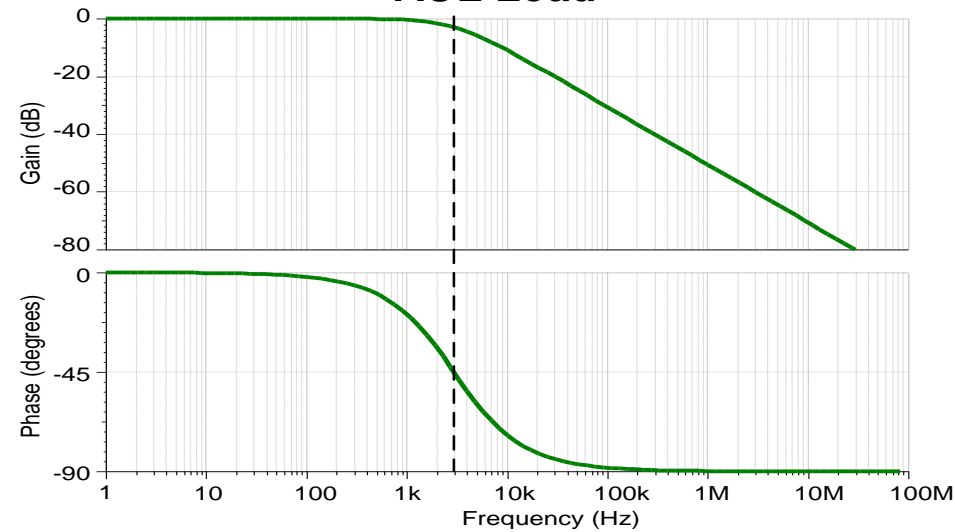

Loaded AOL =

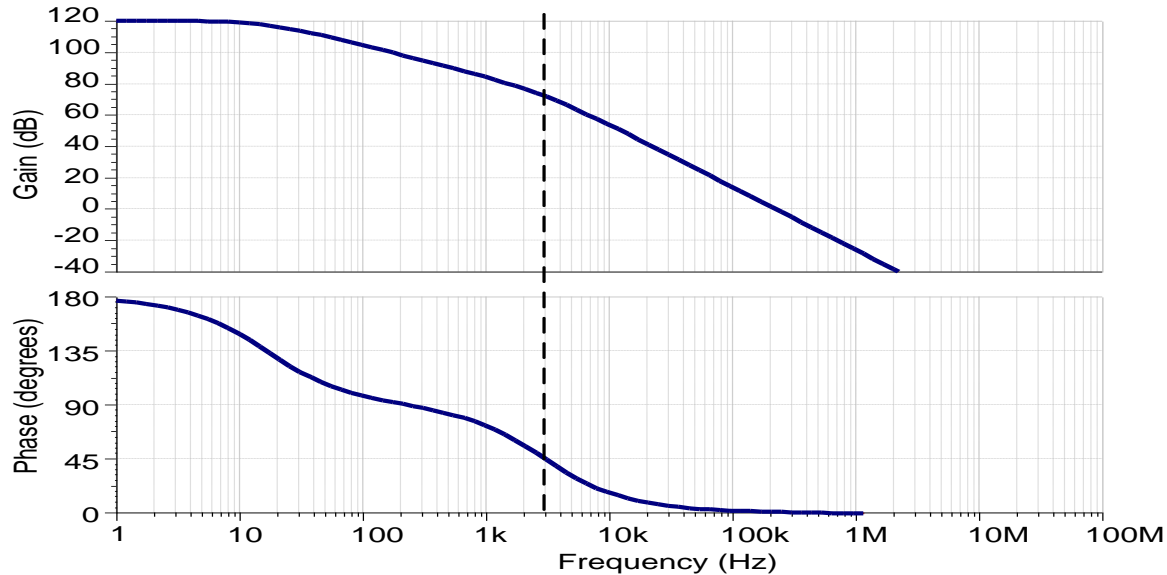

Stabilize Capacitive Loads – Unity Gain Buffers

Stability Options

Unity-Gain circuits can only be stabilized by modifying the AOL load

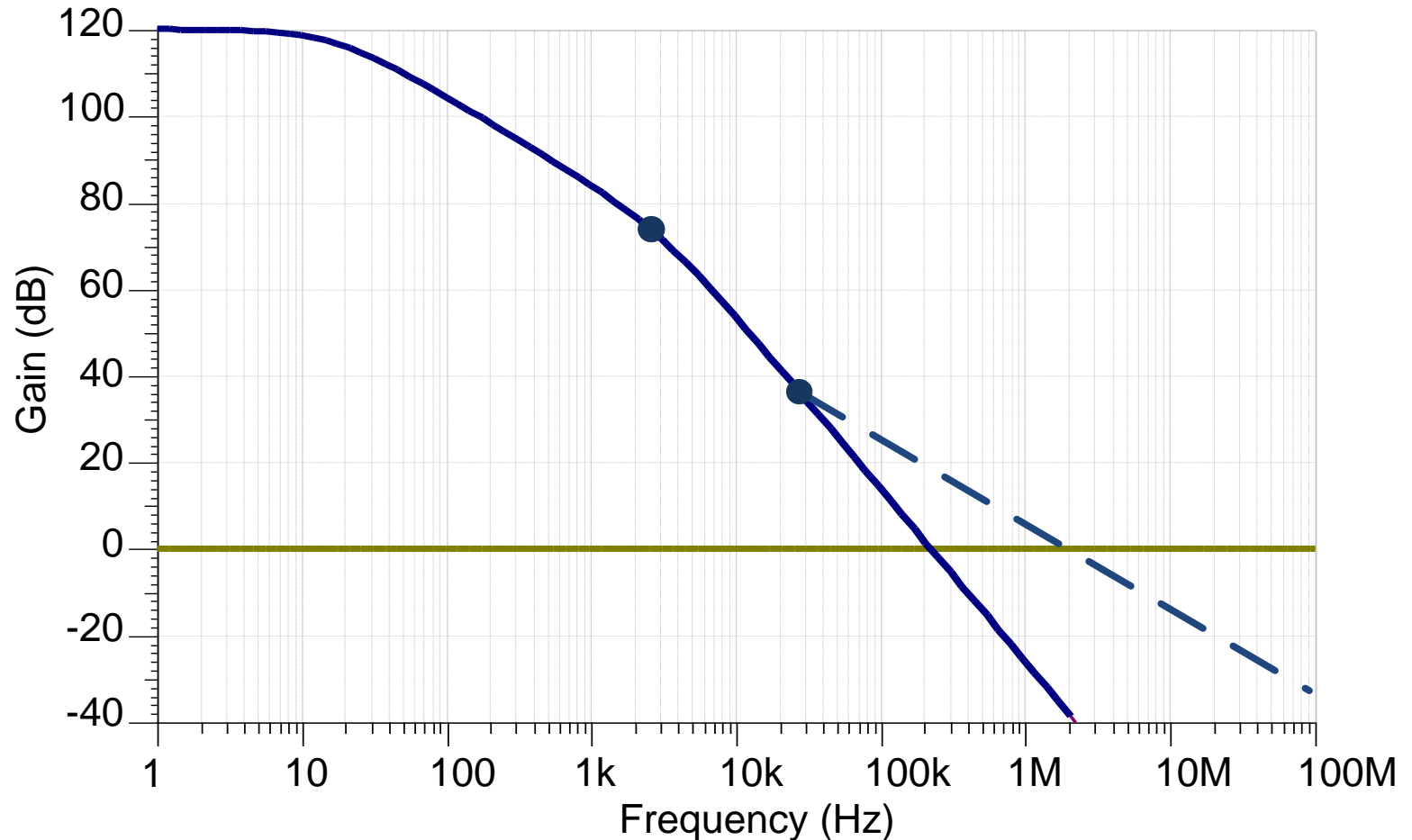

Method 1: Riso

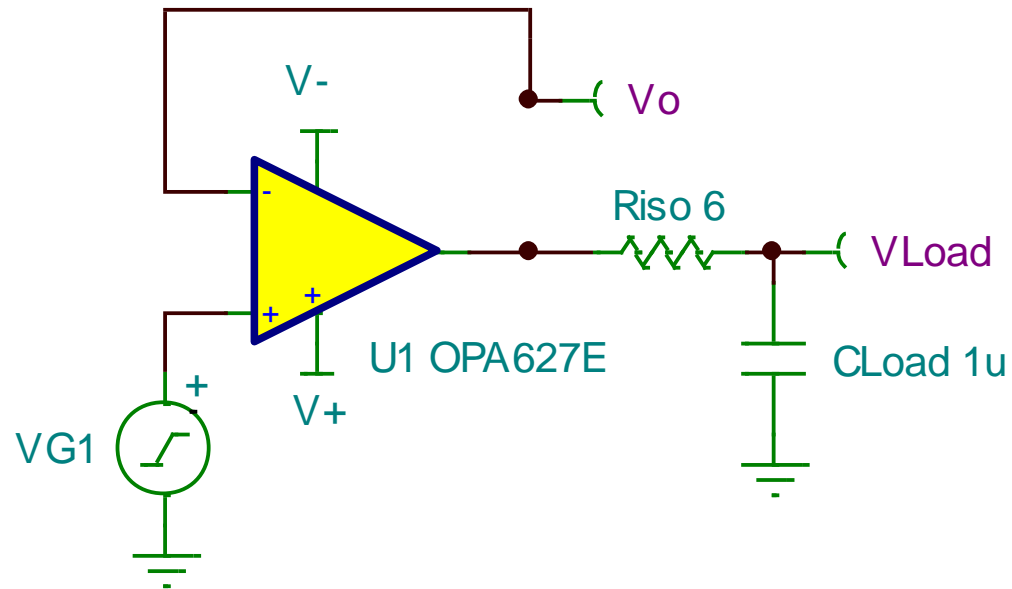

Method 1: Riso - Results

Theory: Adds a zero to the Loaded AOL response to cancel the pole

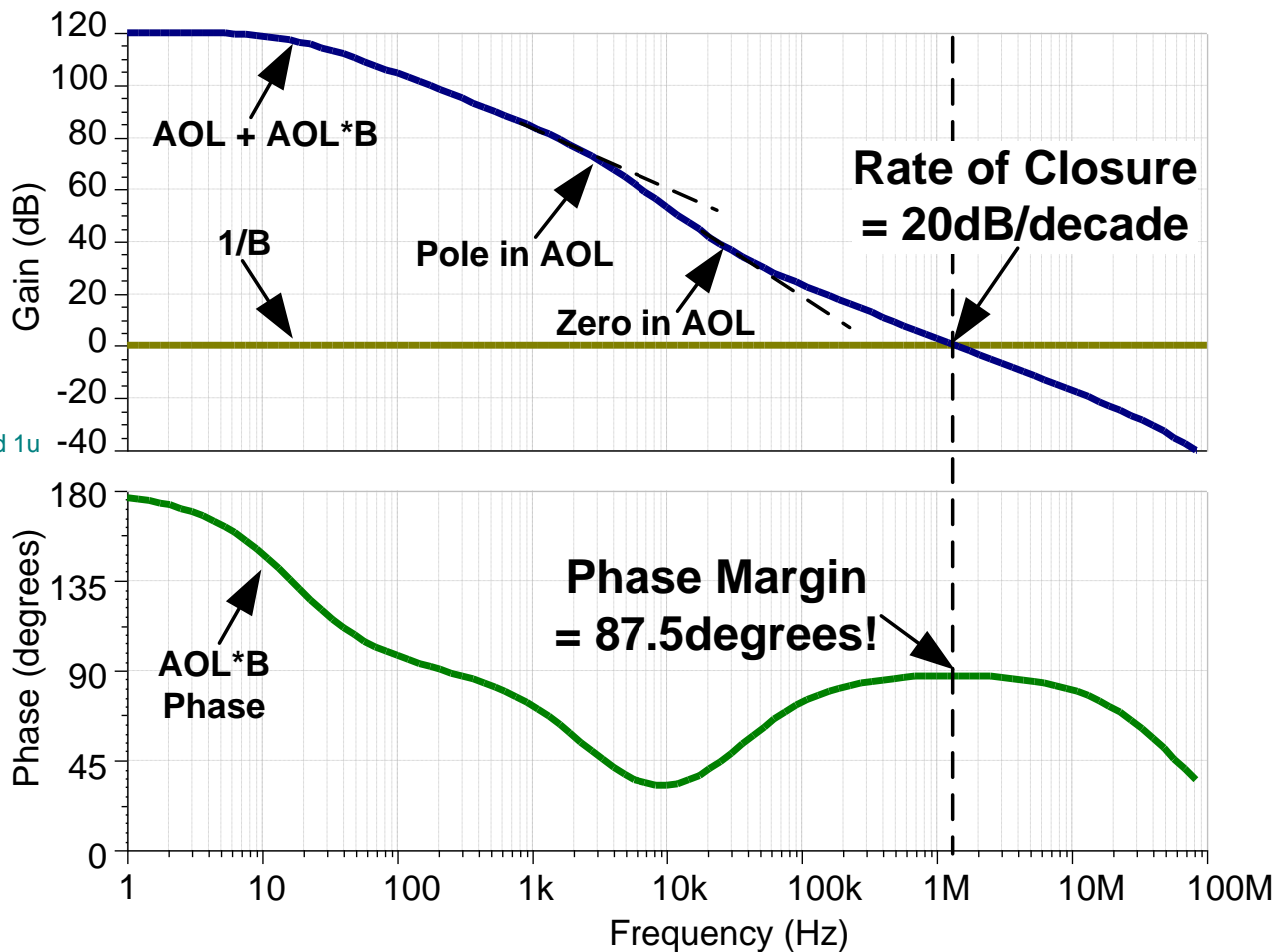
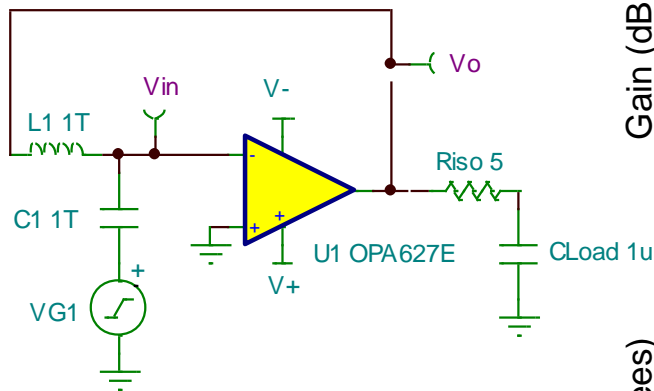

Method 1: Riso - Results

When to use: Works well when DC accuracy is not important, or when loads are very light

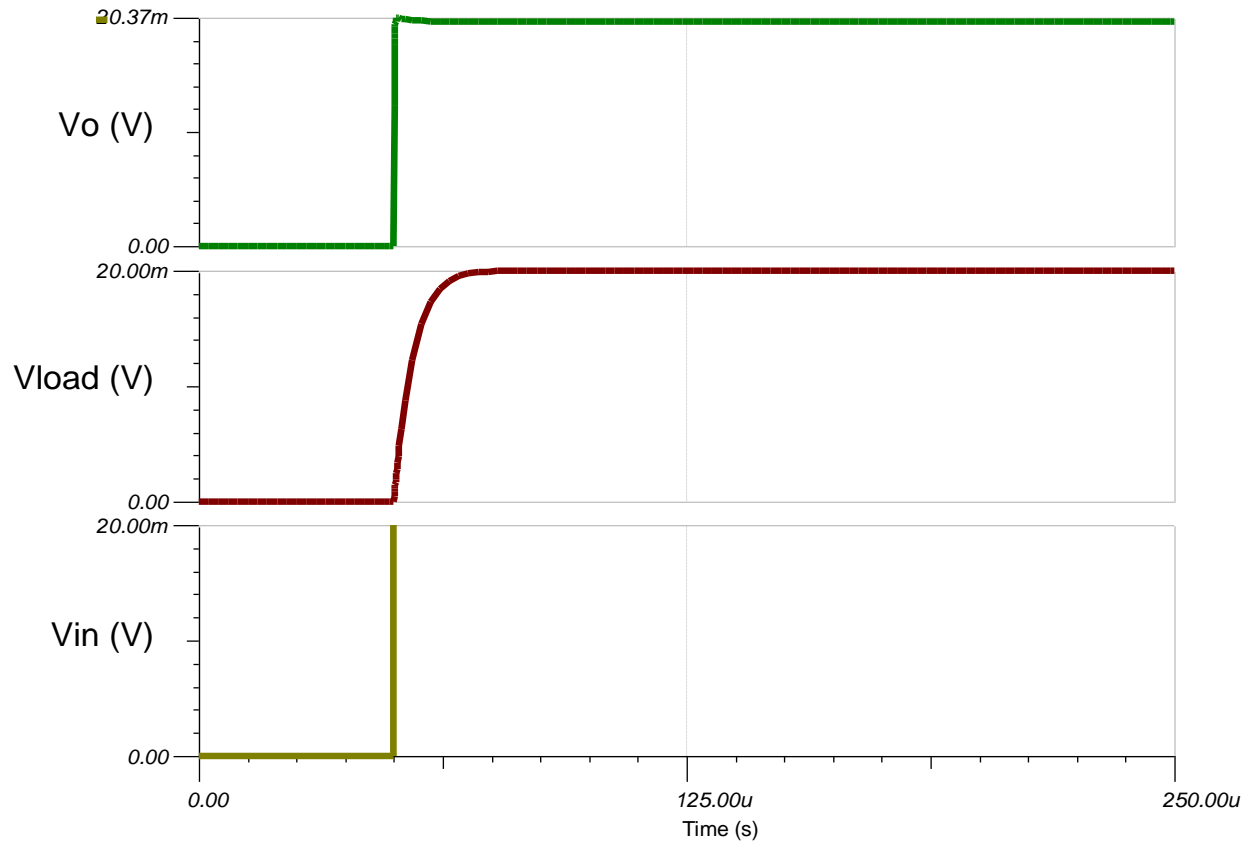
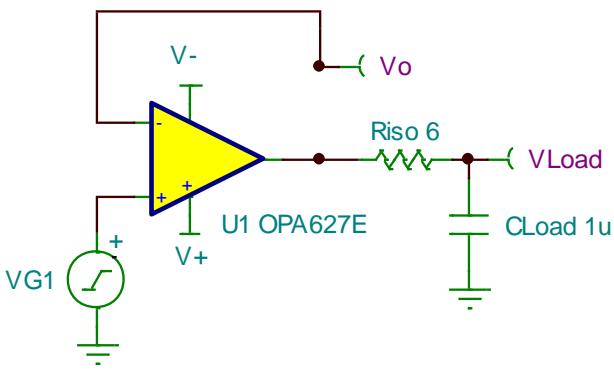

Method 1: Riso - Theory

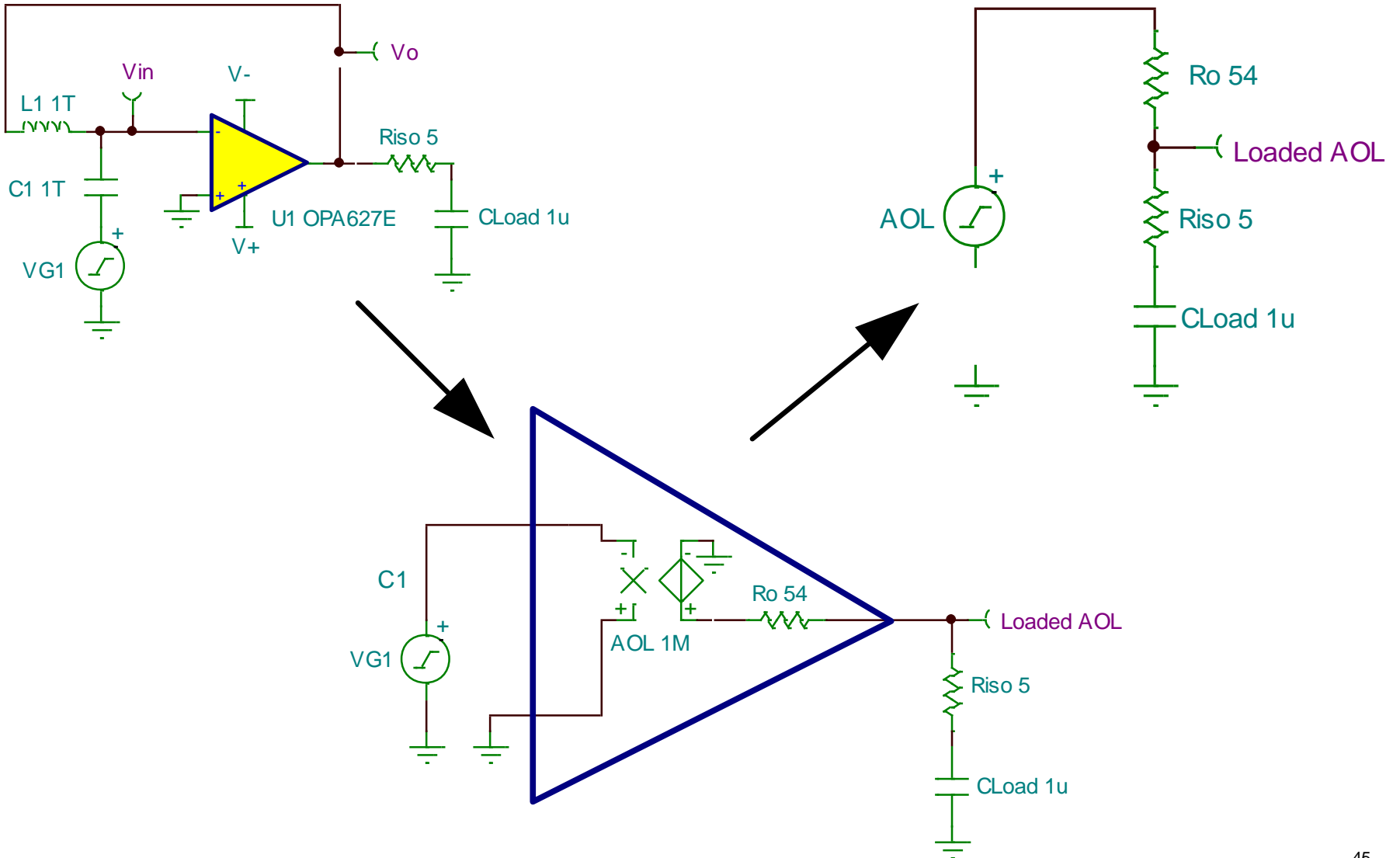

Method 1: Riso - Theory

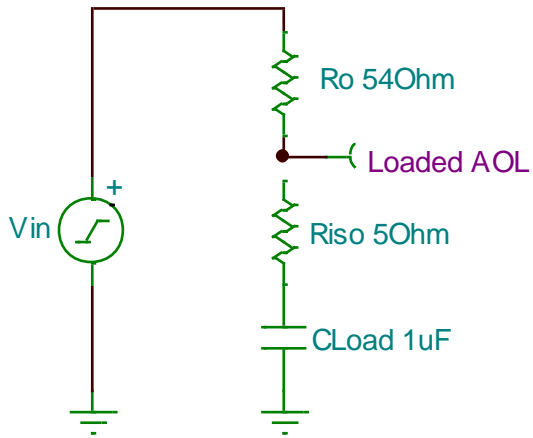

Transfer function:

$$\text{Loaded AOL}(s) = \frac{1 + C_{Load} \cdot R_{iso} \cdot s}{1 + (R_o + R_{iso}) \cdot C_{Load} \cdot s}$$

Pole Equation:

$$f(\text{pole}) = \frac{1}{2 \cdot \pi \cdot (R_o + R_{iso}) \cdot C_{Load} \cdot s}$$

Zero Equation:

$$f(\text{zero}) = \frac{1}{2 \cdot \pi \cdot R_{iso} \cdot C_{Load} \cdot s}$$

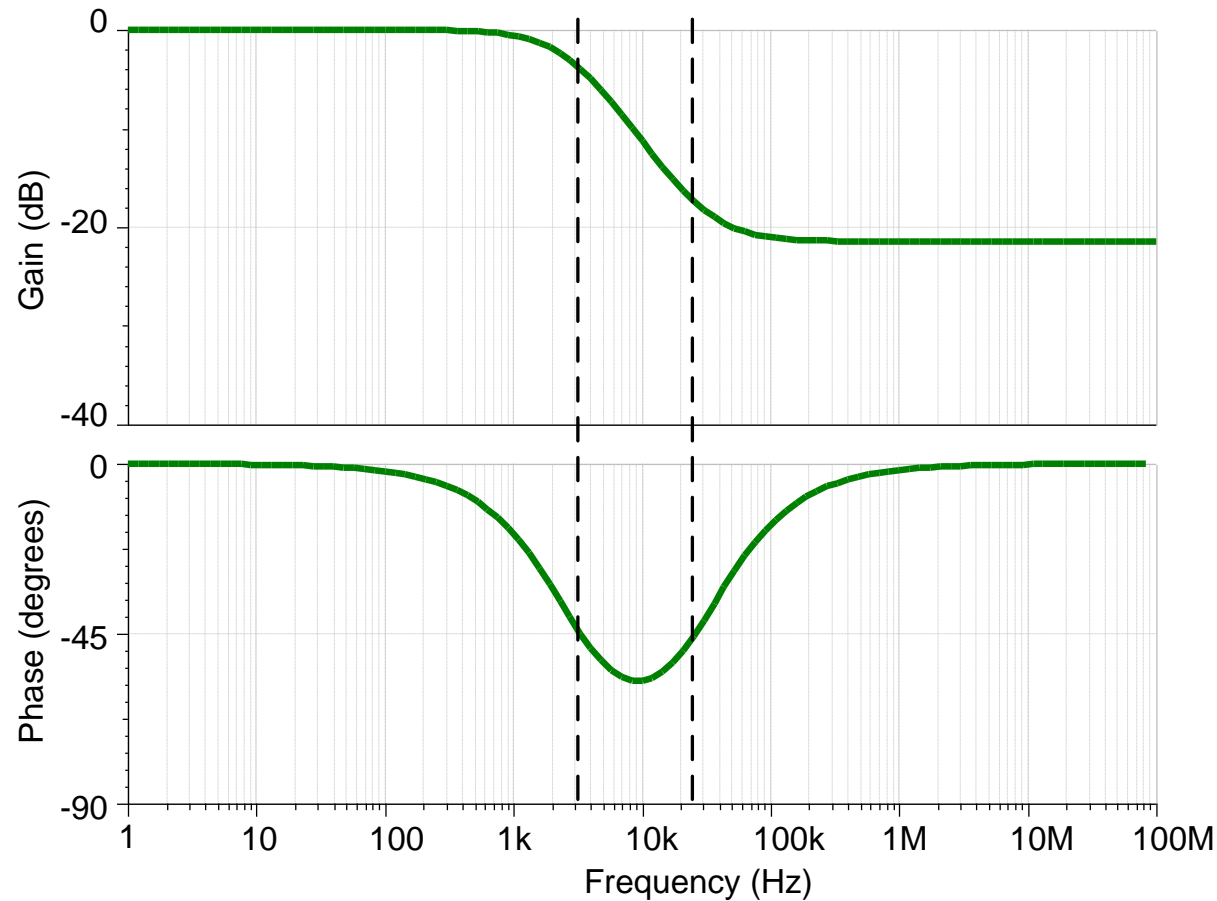

Method 1: Riso - Theory

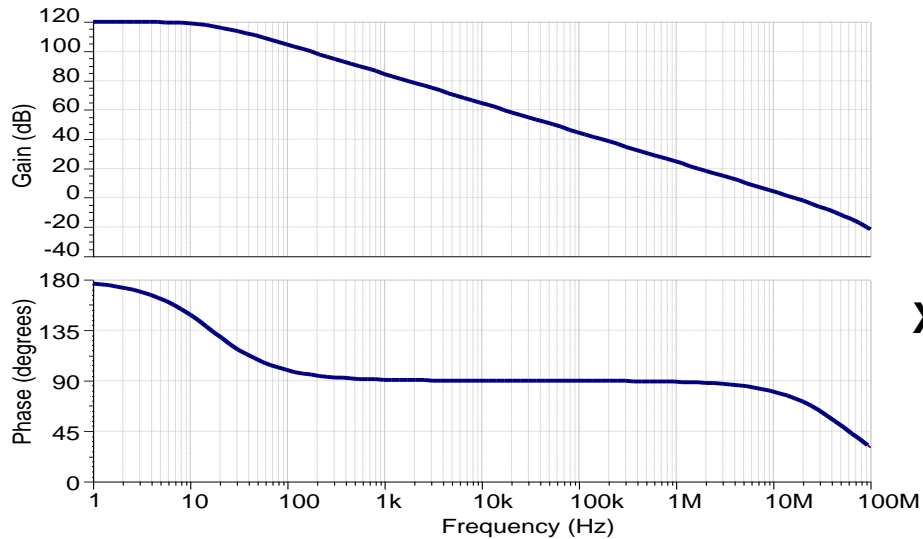

X

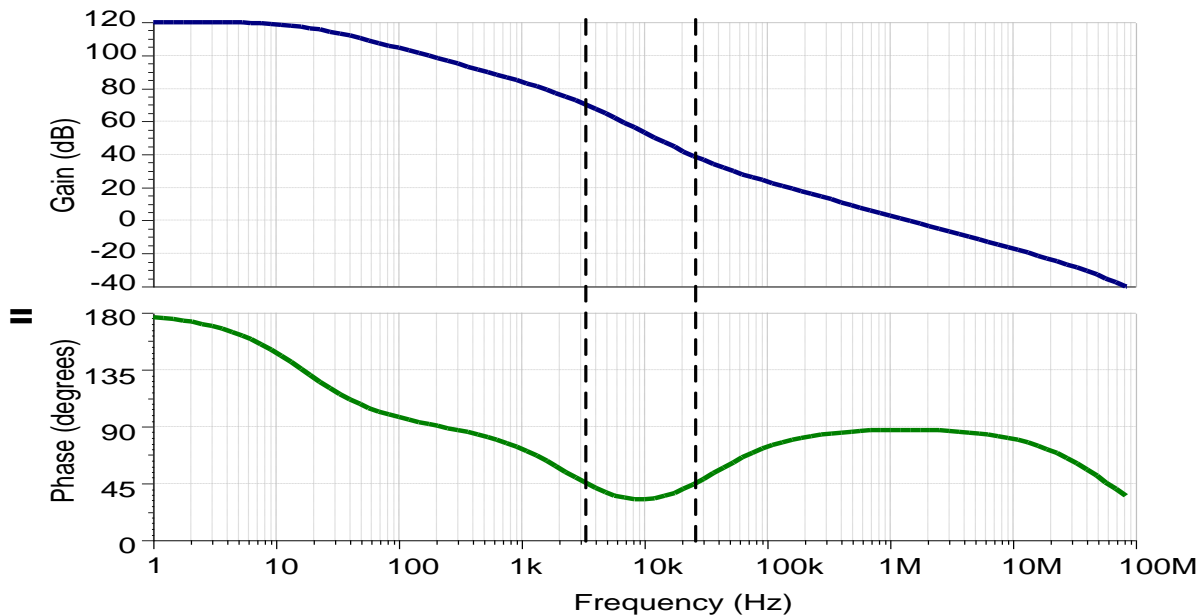
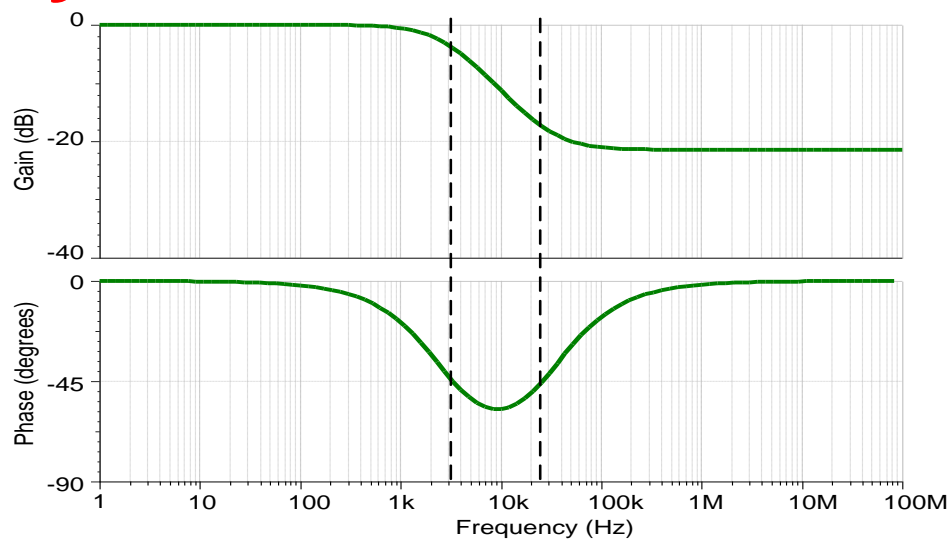

Method 1: Riso - Design

Ensure Good Phase Margin:

1.) Find: f_{cl} and $f(AOL = 20dB)$

2.) Set Riso to create AOL zero:

Good: $f(\text{zero}) = F_{cl}$ for $PM \approx 45$ degrees.

Better: $f(\text{zero}) = F(AOL = 20dB)$ will yield slightly less than 90 degrees phase margin

$f_{cl} = 222.74\text{kHz}$

$f(AOL = 20dB) = 70.41\text{kHz}$

Zero Equation:

$$f(\text{zero}) = \frac{1}{2 \cdot \pi \cdot R_{iso} \cdot C_{Load} \cdot s}$$

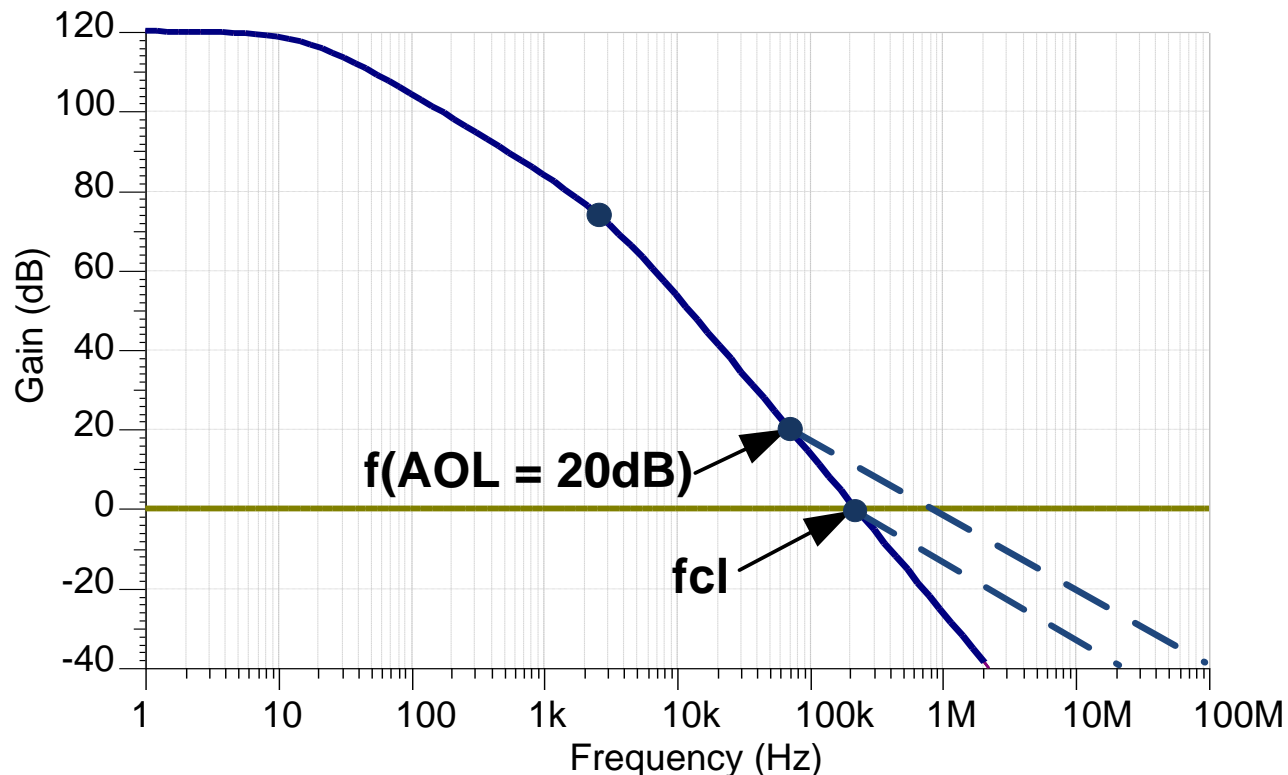

Method 1: Riso - Design

$$f(\text{zero}) = \frac{1}{2 \cdot \pi \cdot R_{\text{iso}} \cdot C_{\text{Load}} \cdot S}$$

Ensure Good Phase Margin: Test

$f(\text{AOL} = 20\text{dB}) = 70.41\text{kHz}$

→ $R_{\text{iso}} = 2.26\text{Ohms}$

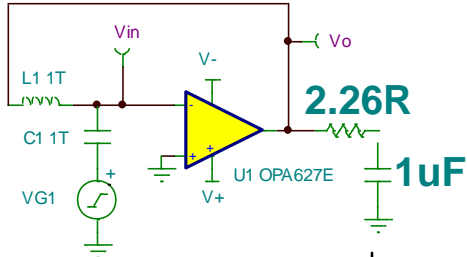

$f_{\text{cl}} = 222.74\text{kHz}$

→ $R_{\text{iso}} = 0.715\text{Ohms}$

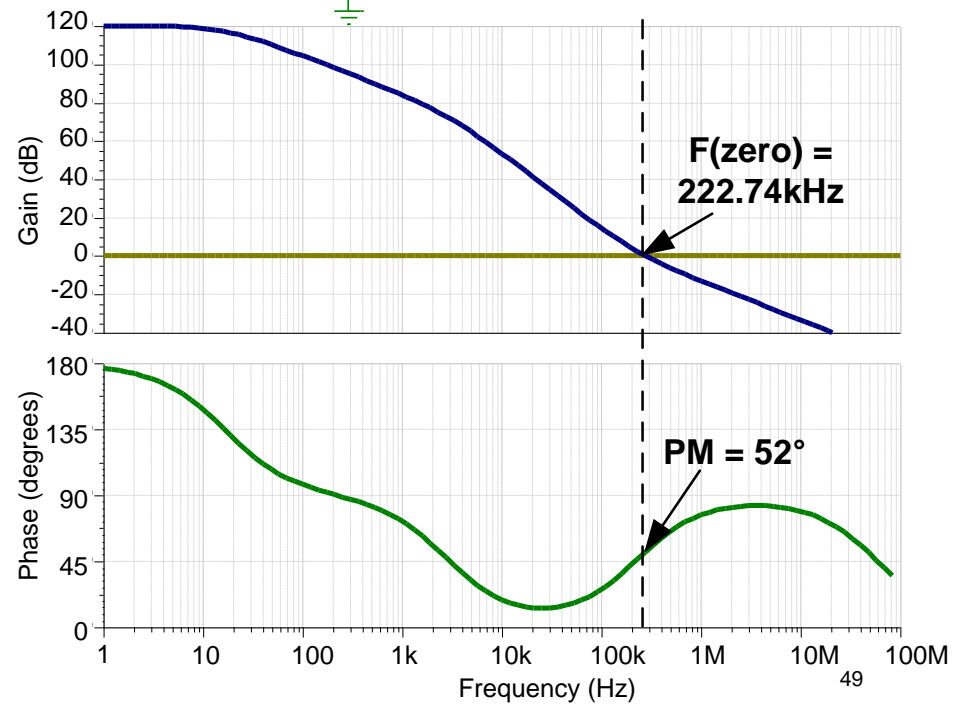
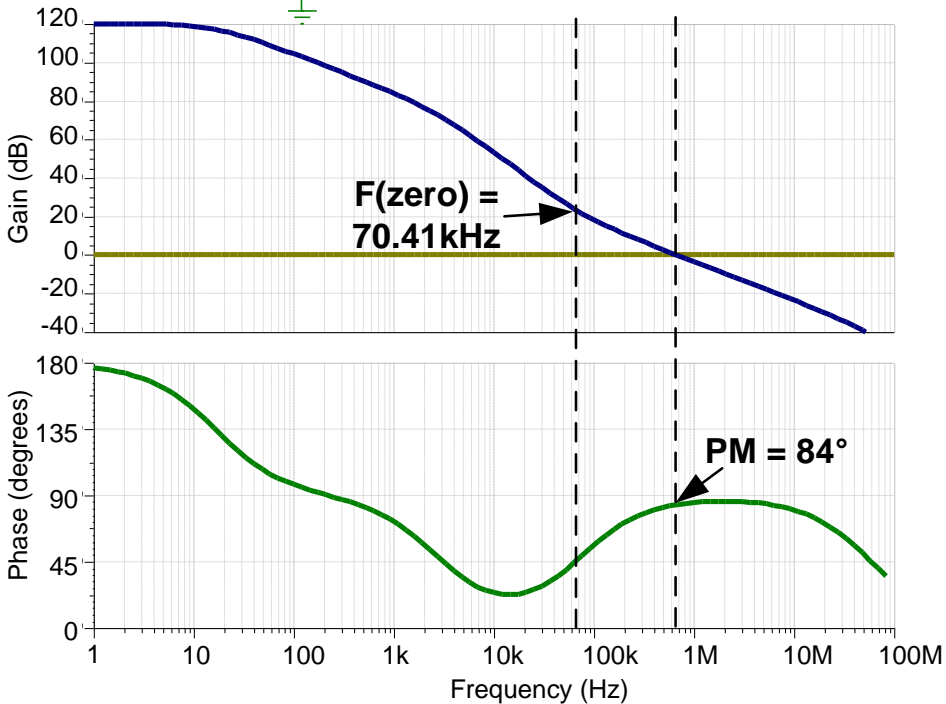
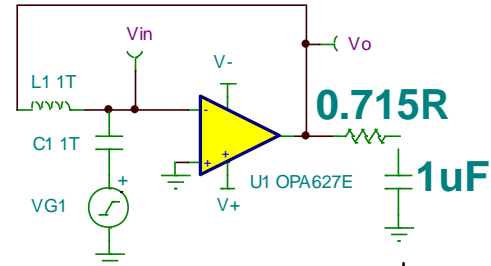

Method 1: Riso - Design

Prevent Phase Dip:

Place the zero less than 1 decade from the pole, no more than 1.5 decades away

Good: 1.5 Decades: $F(\text{zero}) \leq 35 * F(\text{pole}) \rightarrow \text{Riso} \geq \text{Ro}/34 \rightarrow 70^\circ \text{ Phase Shift}$

Better: 1 Decade: $F(\text{zero}) \leq 10 * F(\text{pole}) \rightarrow \text{Riso} \geq \text{Ro}/9 \rightarrow 55^\circ \text{ Phase Shift}$

Riso = Ro/9

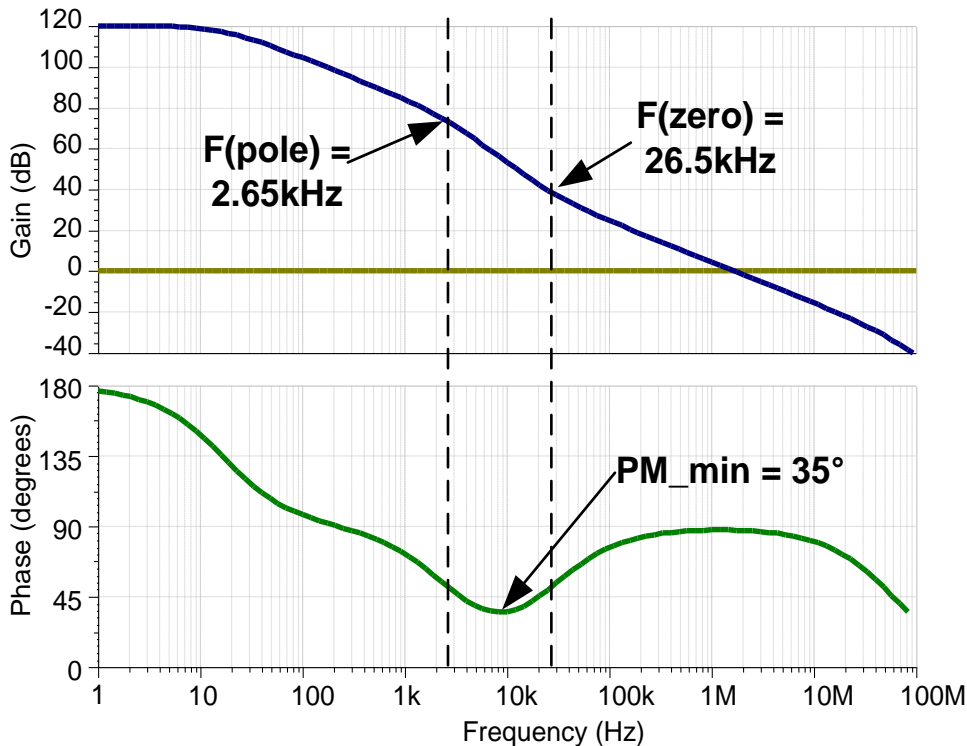

Riso = Ro/34

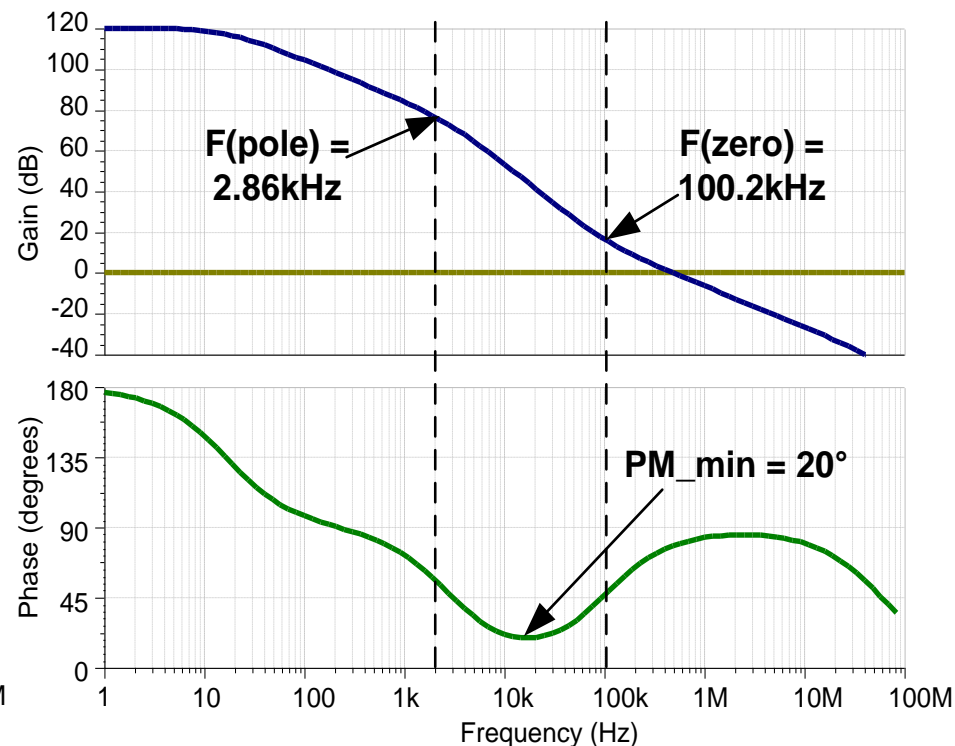

Method 1: Riso - Design

Prevent Phase Dip: Ratio of Riso to Ro

If $R_{iso} \geq 2 \cdot R_o \rightarrow F(\text{zero}) = 1.5 \cdot F(\text{pole}) \rightarrow \sim 10^\circ$ Phase Shift

**Almost completely cancels the pole.

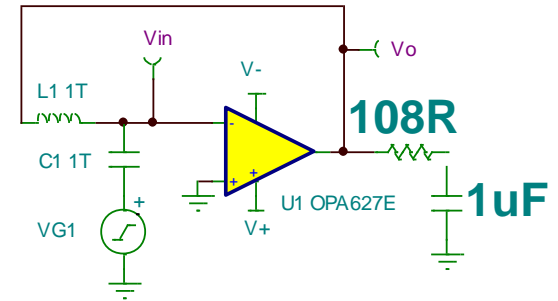

Riso = Ro*2

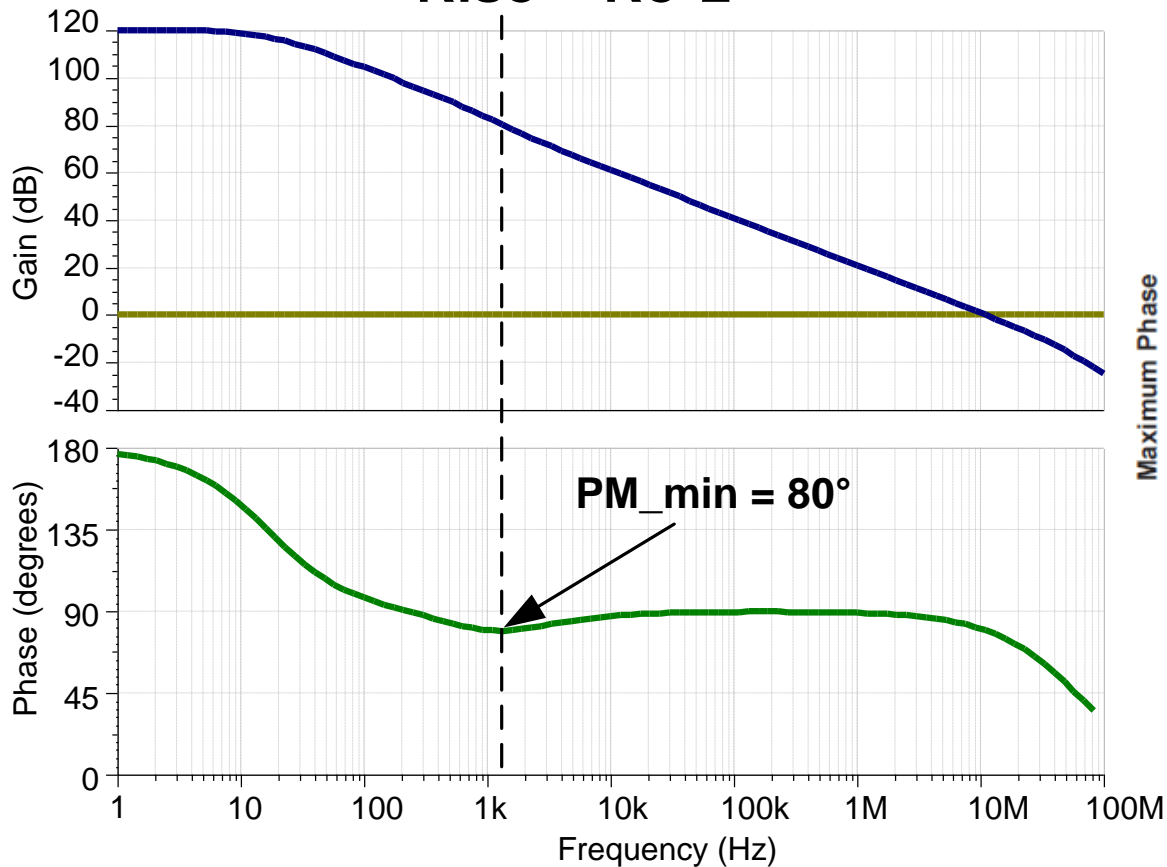

Phase Shift vs. Riso/Ro

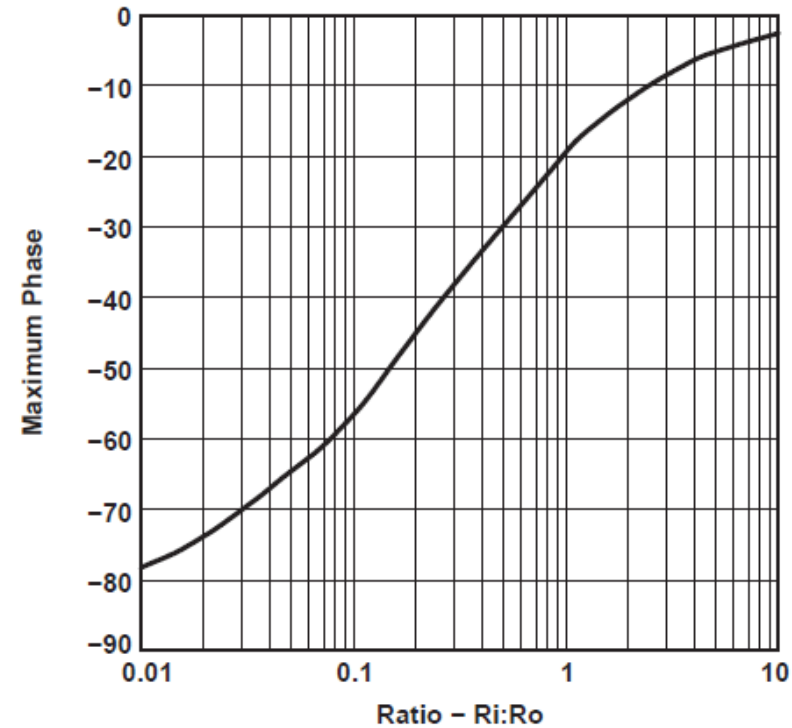

Method 1: Riso – Design Summary

Summary:

- 1.) Ensure stability by placing $F_{zero} \leq F(AOL=20dB)$
- 2.) If F_{zero} is > 1.5 decades from $F(pole)$ then increase R_{iso} up to at least $R_o/34$
- 3.) If loads are very light consider increasing $R_{iso} > R_o$ for stability across all loads

Final Circuit

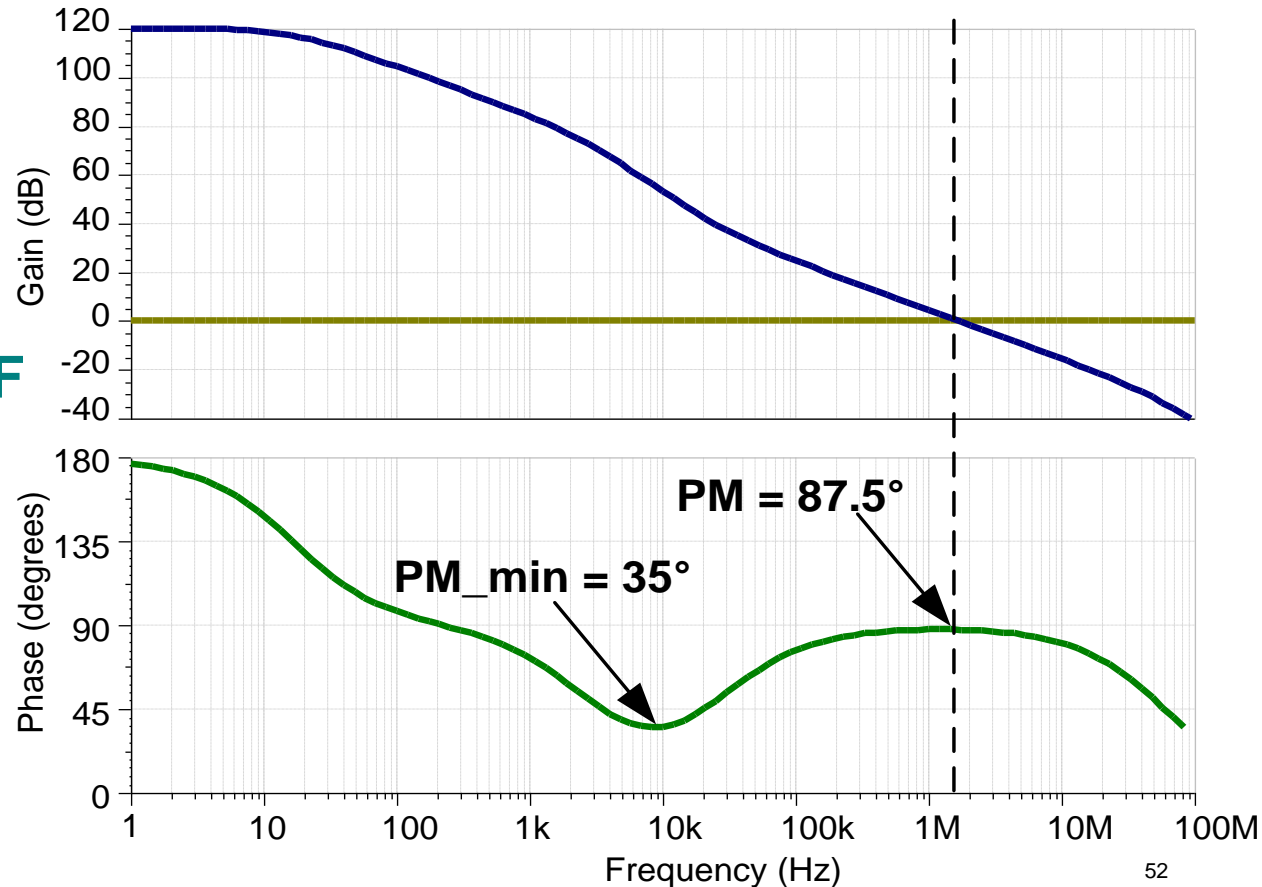
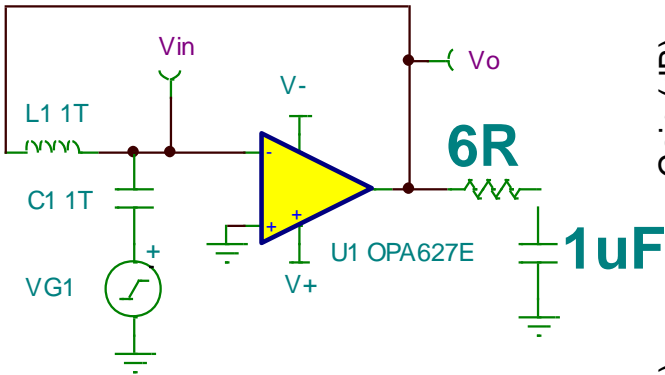

Method 1: Riso - Disadvantage

Disadvantage:

Voltage drop across Riso may not be acceptable

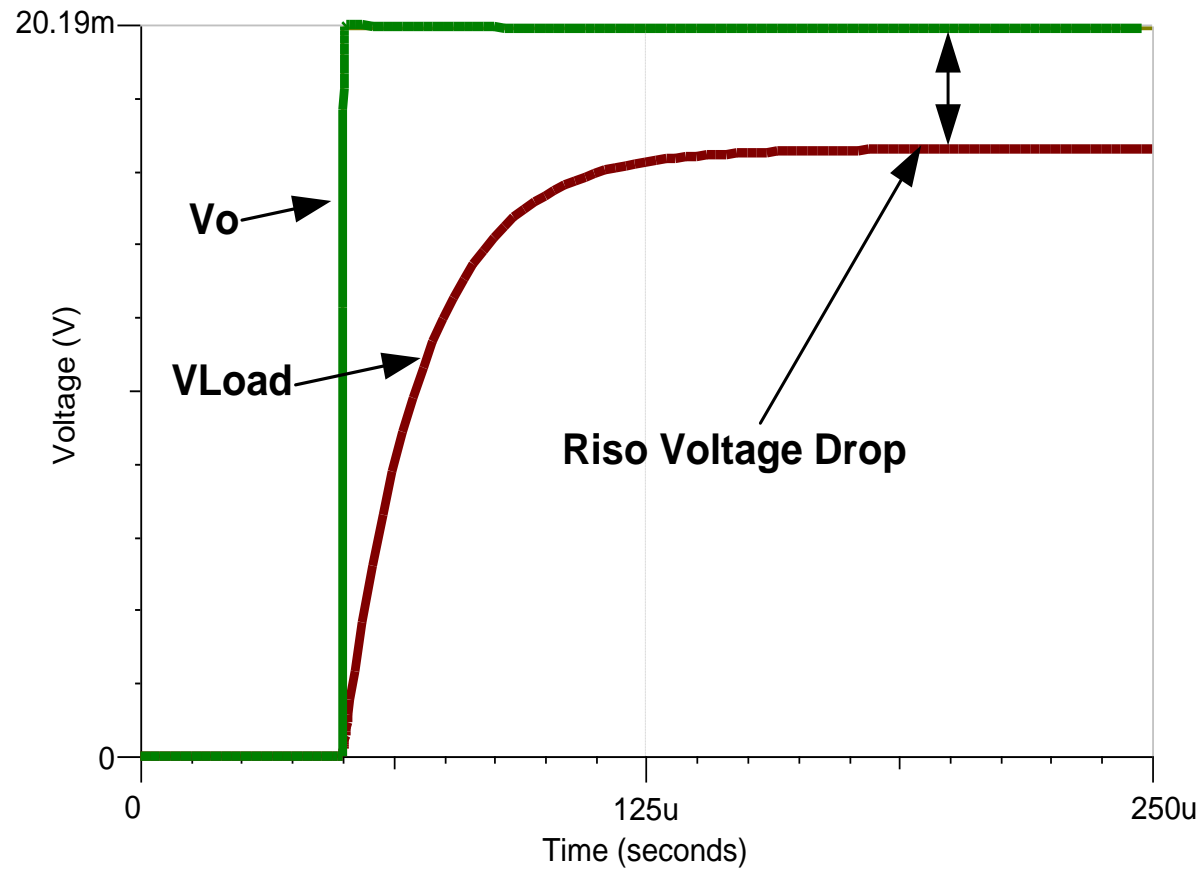
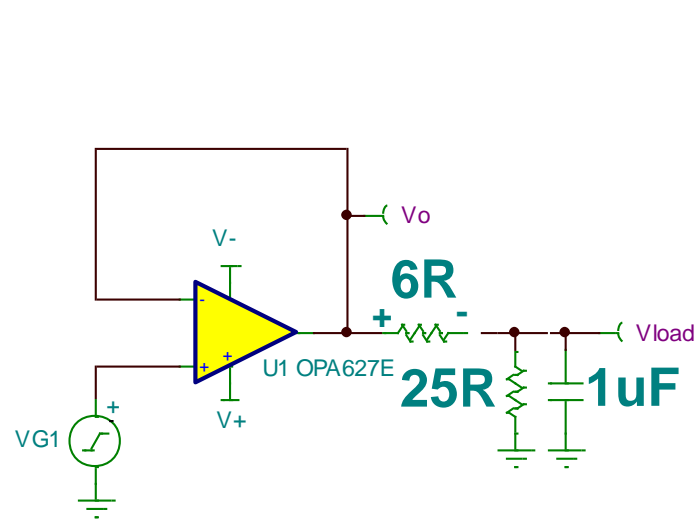

Method 2: Riso + Dual Feedback

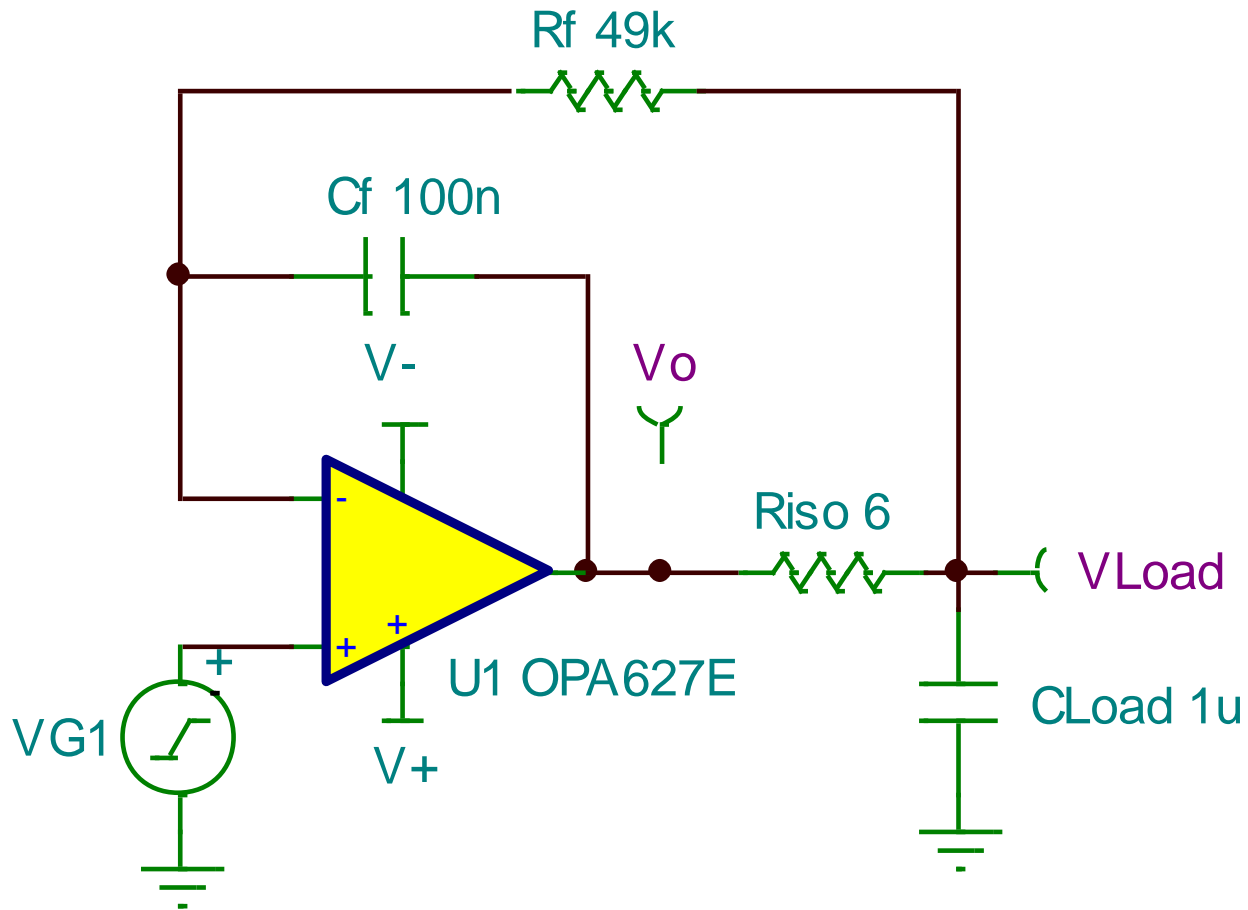

Method 2: Riso + Dual Feedback

Theory: Features a low-frequency feedback to cancel the Riso drop and a high-frequency feedback to create the AOL pole and zero.

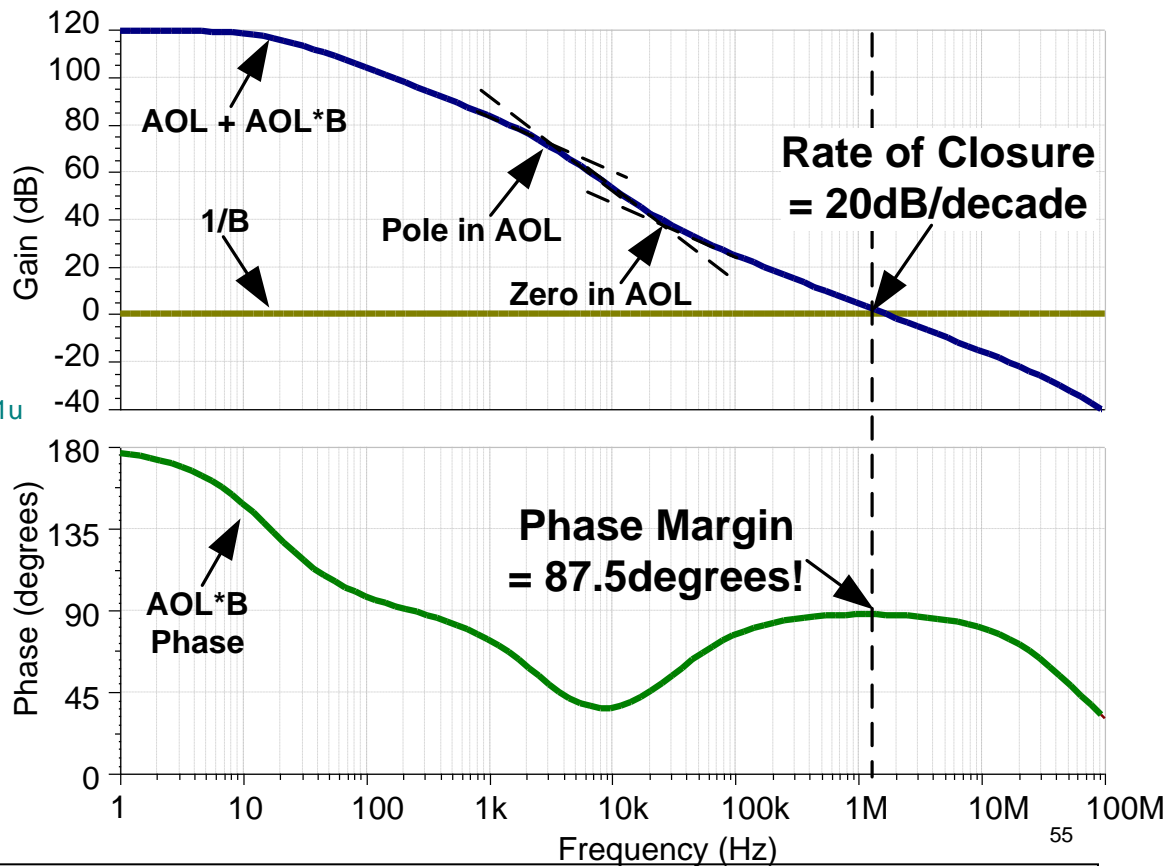
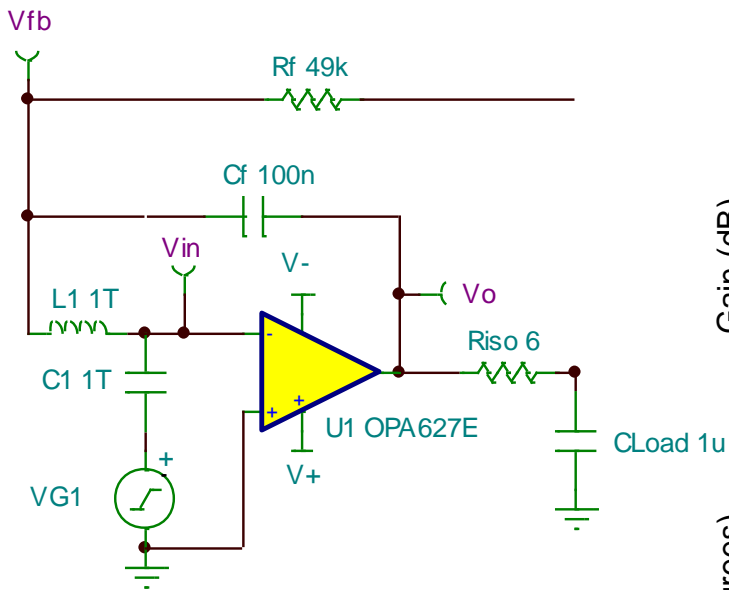

Method 2: Riso + Dual Feedback

When to Use: Only practical solution for very large capacitive loads $\geq 10\mu\text{F}$

When DC accuracy must be preserved across different current loads

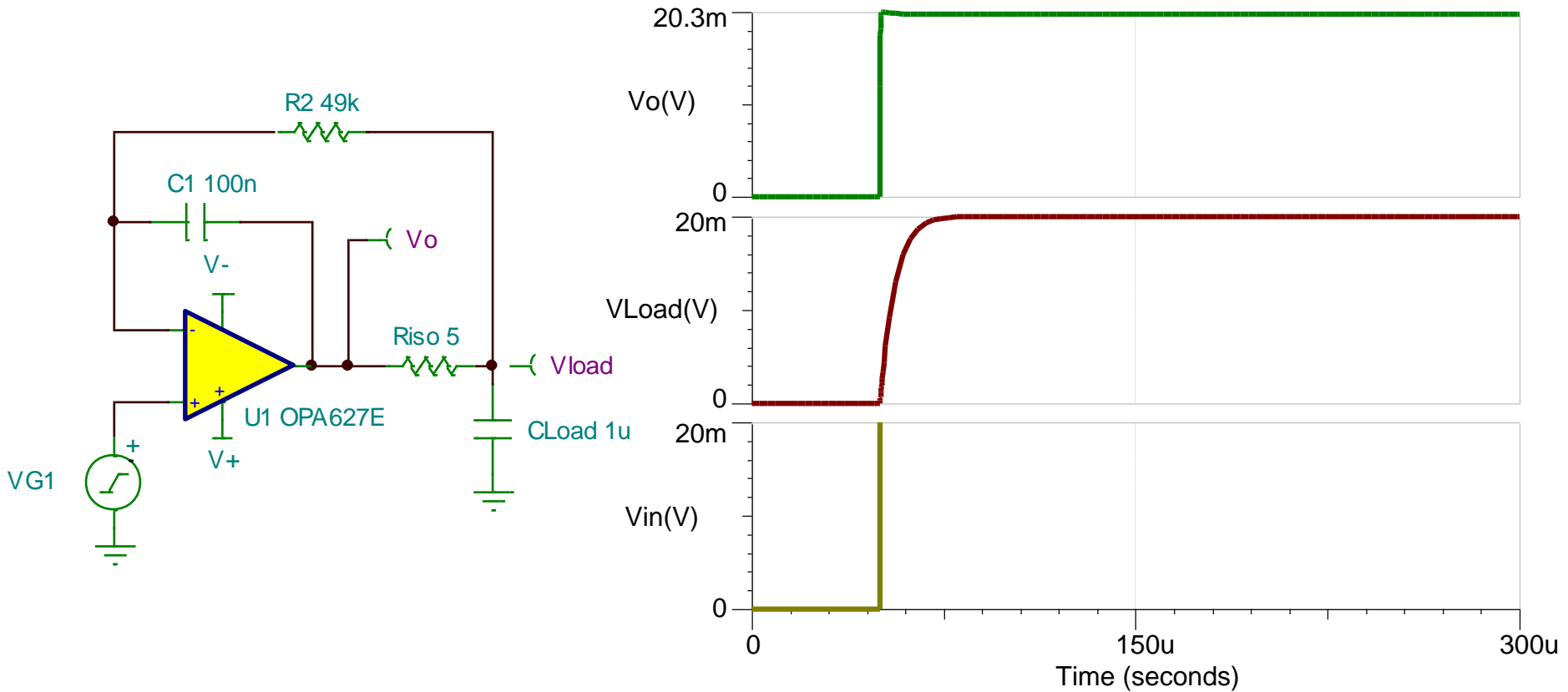

Method 2: Riso + Dual Feedback - Design

Ensure Good Phase Margin:

- 1.) Find: f_{cl} and $f(\text{AOL} = 20\text{dB})$
- 2.) Set R_{iso} to create AOL zero:
Good: $f(\text{zero}) = F_{cl}$ for $PM \approx 45$ degrees.
Better: $f(\text{zero}) = F(\text{AOL} = 20\text{dB})$ will yield slightly less than 90 degrees phase margin
- 3.) Set R_f so $R_f \gg R_{iso}$
 $R_f \geq (R_{iso} * 100)$
- 4.) Set $C_f \geq (200 * R_{iso} * C_{load}) / R_f$

$f_{cl} = 222.74\text{kHz}$

$f(\text{AOL} = 20\text{dB}) = 70.41\text{kHz}$

Zero Equation:

$$f(\text{zero}) = \frac{1}{2 \cdot \pi \cdot R_{iso} \cdot C_{Load} \cdot s}$$

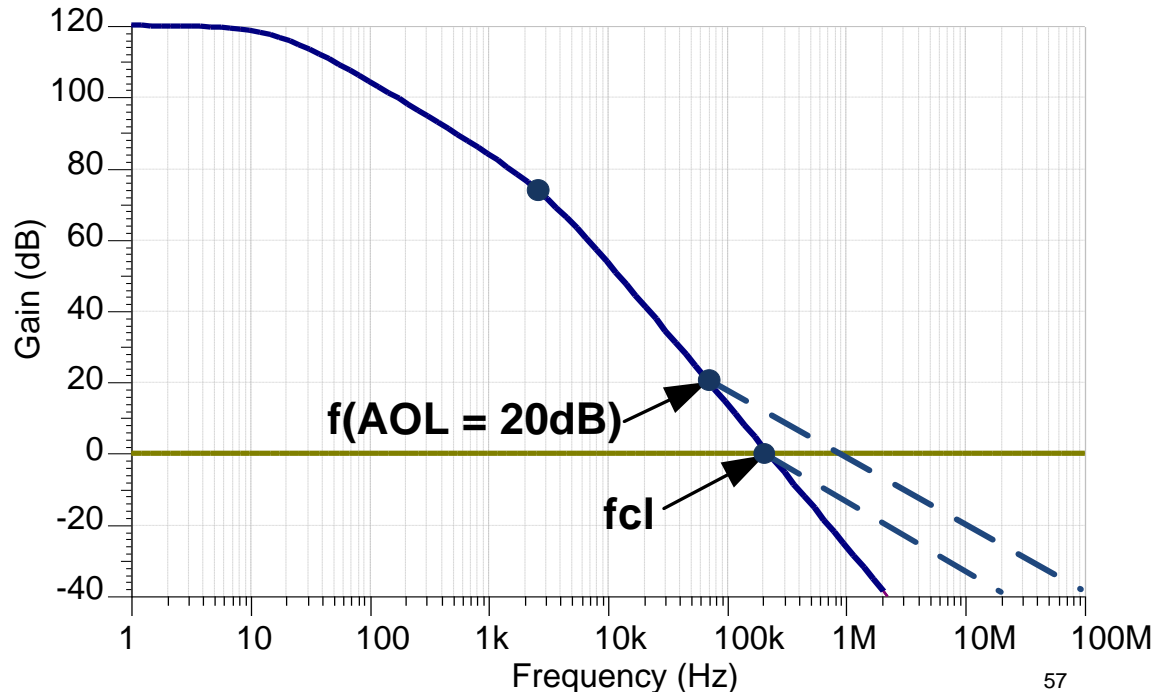

Method 2: Riso + Dual Feedback - Summary

Ensure Good Phase Margin (Same as “Riso” Method):

- 1.) Set Riso so $f(\text{zero}) = F(\text{AOL} = 20\text{dB})$
- 2.) Set Rf: $R_f \geq (\text{Riso} * 100)$
- 3.) Set Cf: $C_f \geq (200 * \text{Riso} * \text{Cload}) / R_f$

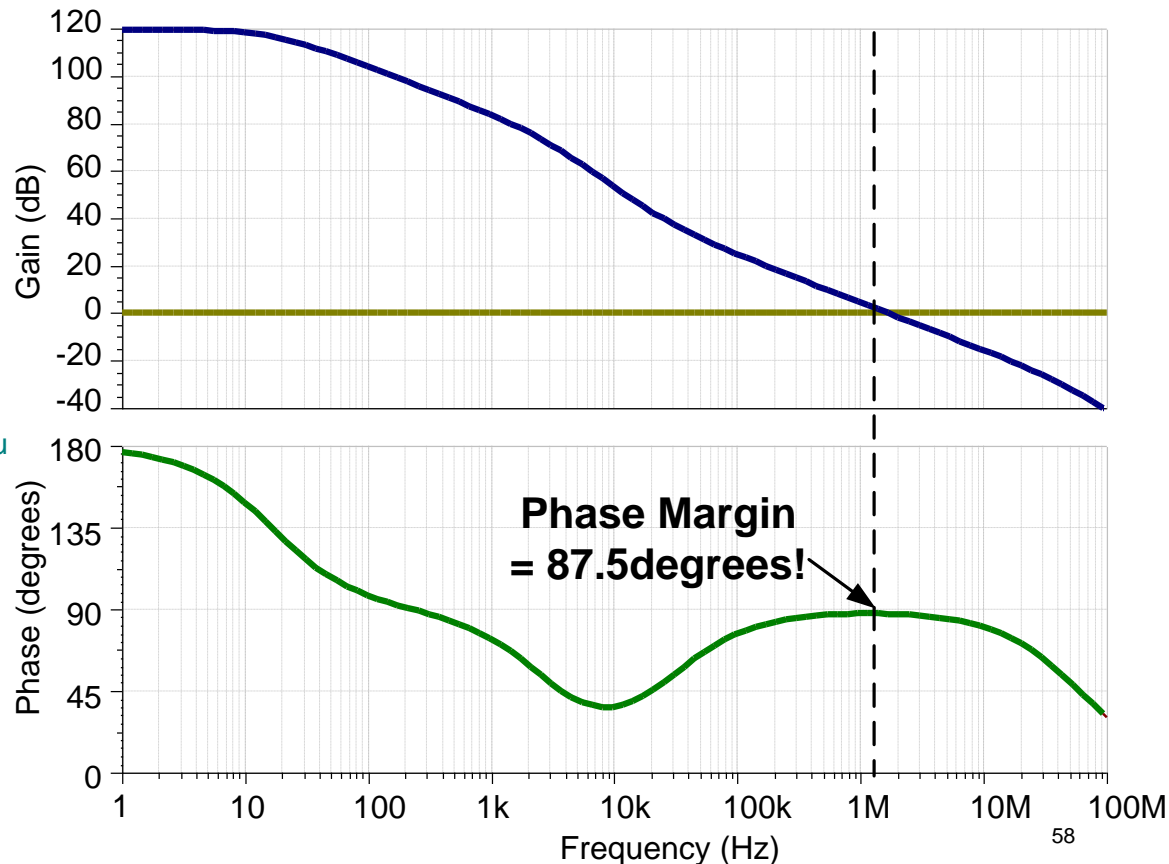
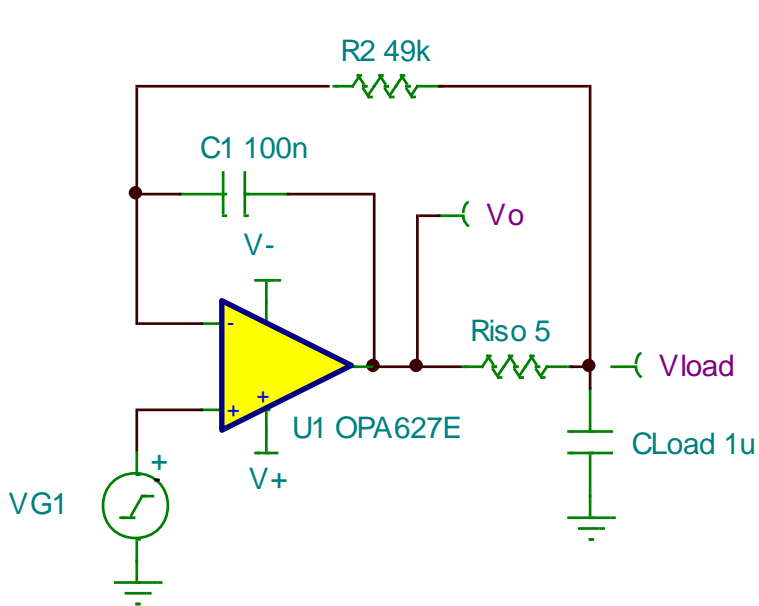

Capacitive Loads – Circuits with Gain

Capacitive Loads – Circuits with Gain

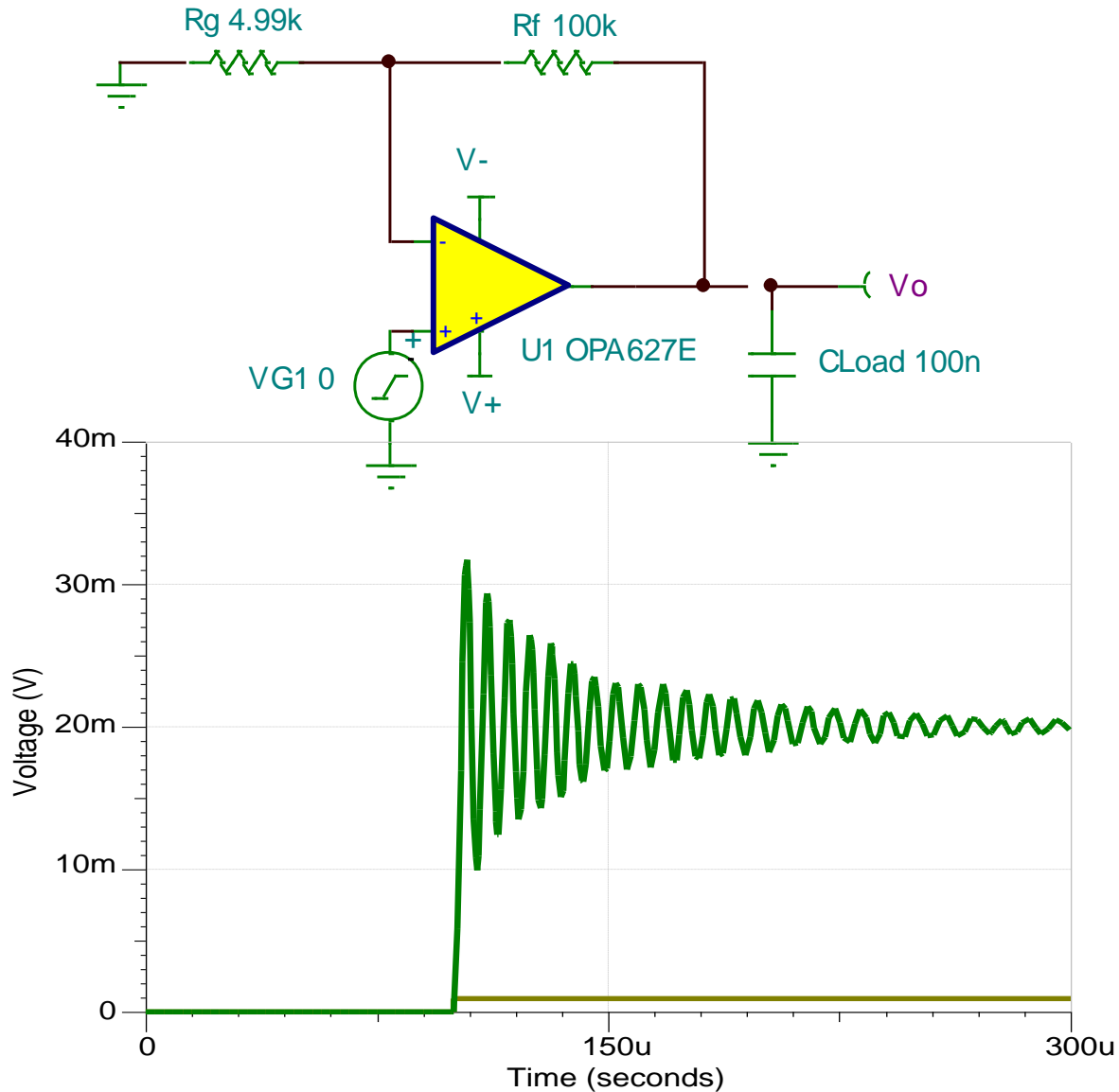

Capacitive Loads – Circuits With Gain - Results

Same Issues as Unity Gain Circuit

Pole in AOL!!

ROC = 40dB/decade!!

Phase Margin = 10°!!

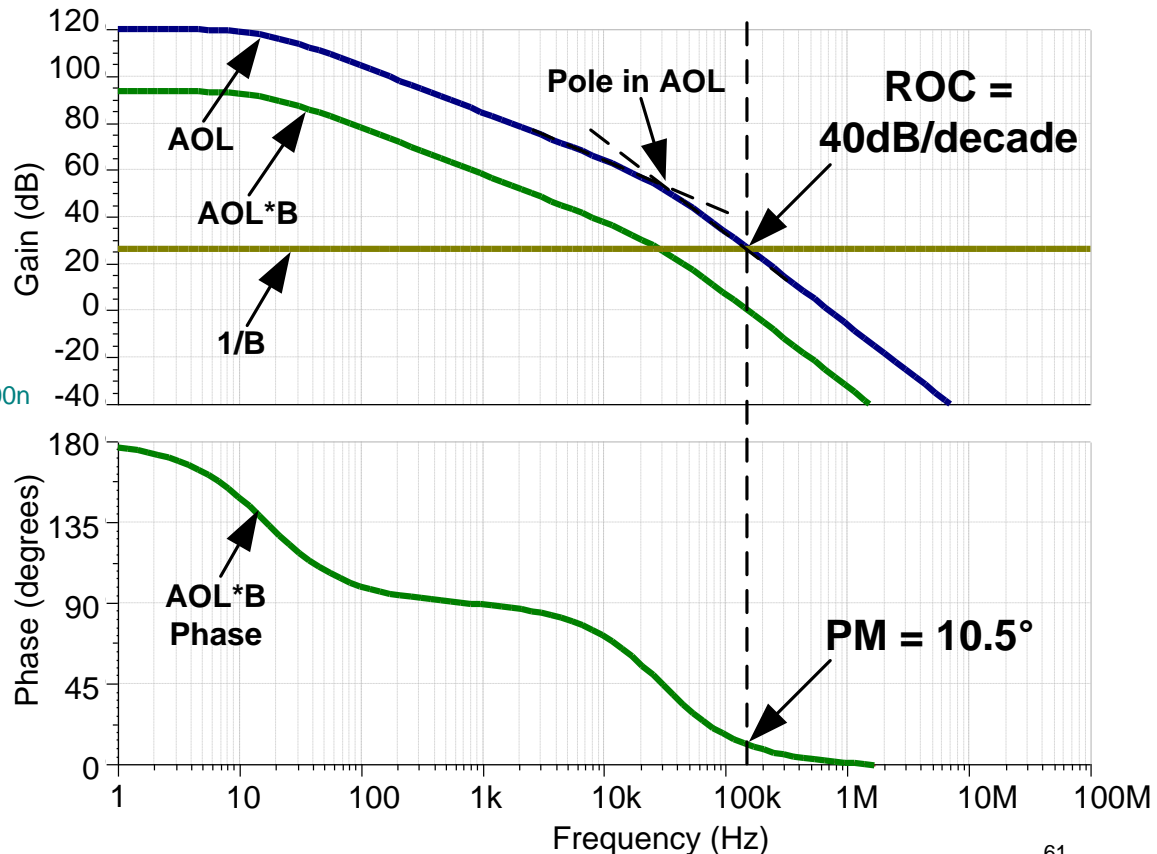
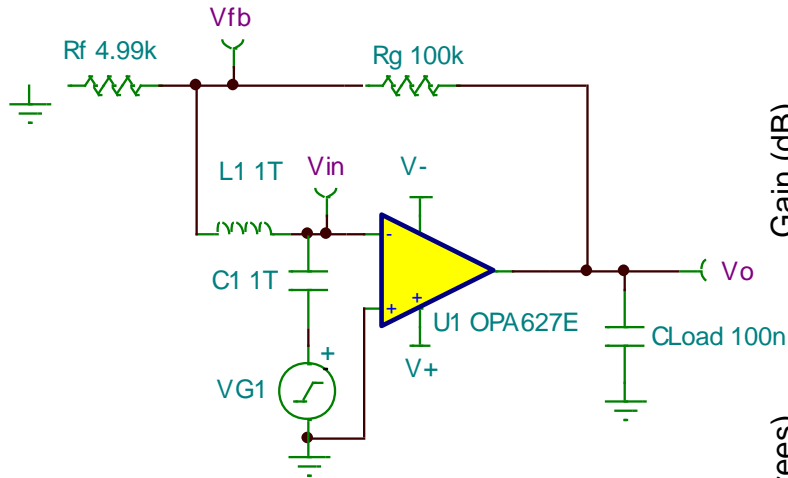

Stabilize Capacitive Loads – Circuits with Gain

Stability Options – Circuits with Gain

Circuits with gain can be stabilized by modifying the AOL load and by modifying 1/Beta

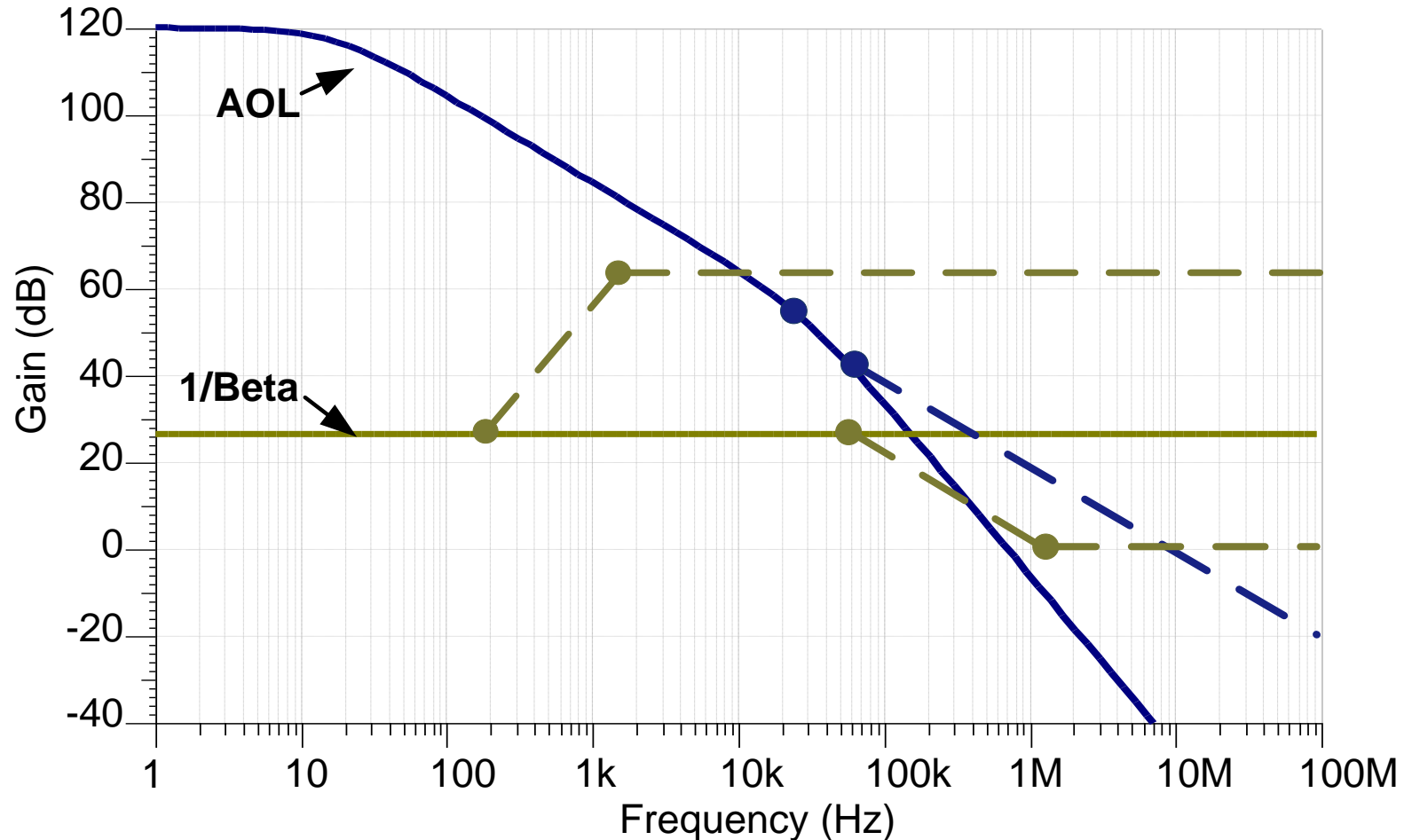

Method 1 + Method 2

Methods 1 and 2 work on circuits with gain as well!

Method 1: Riso

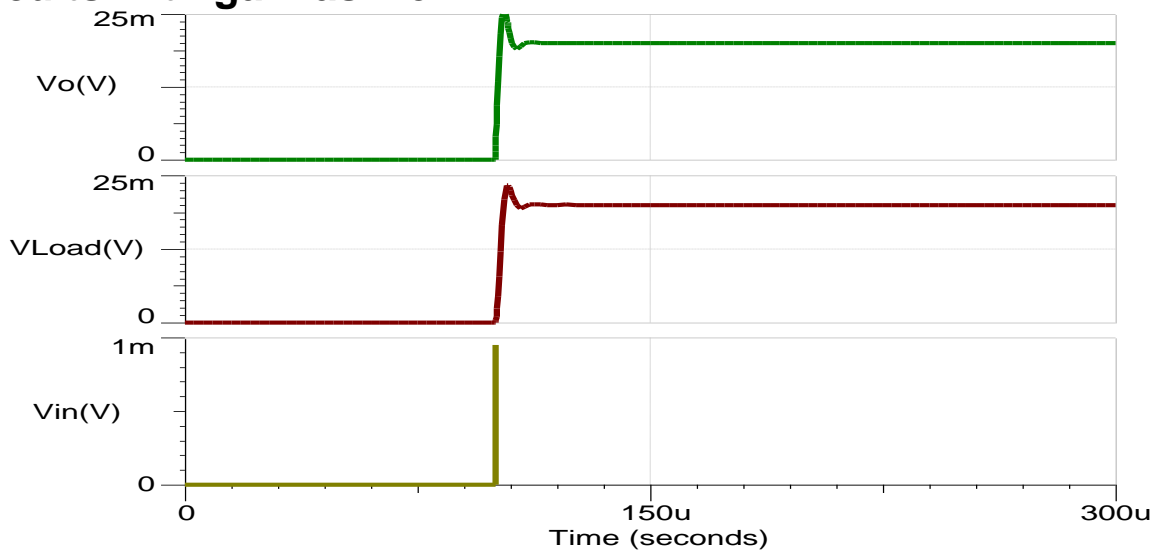
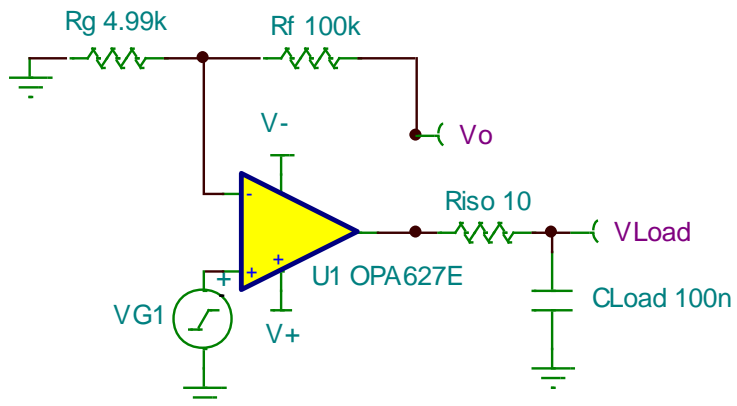

Method 2: Riso+Dual Feedback

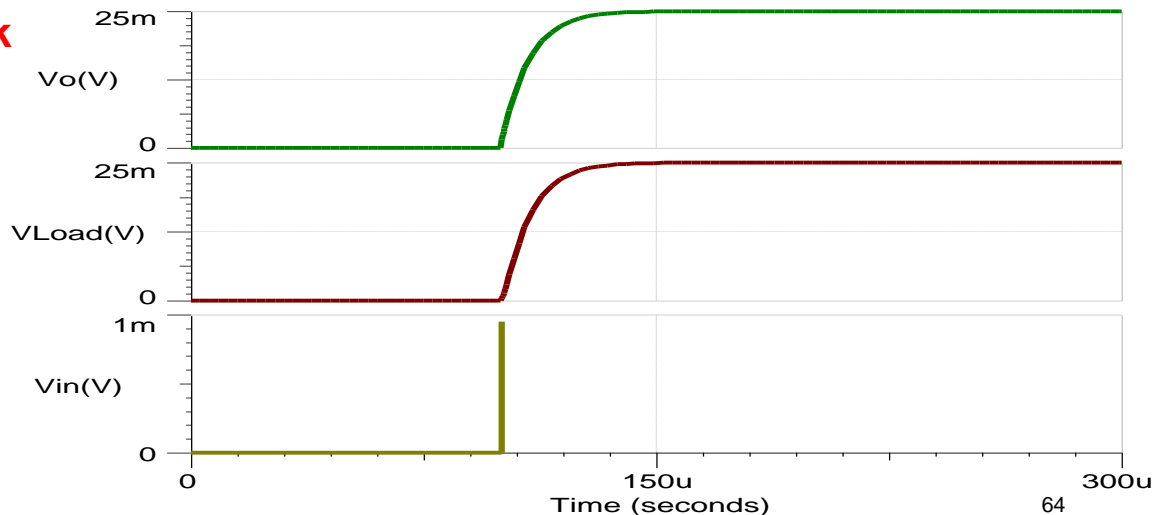
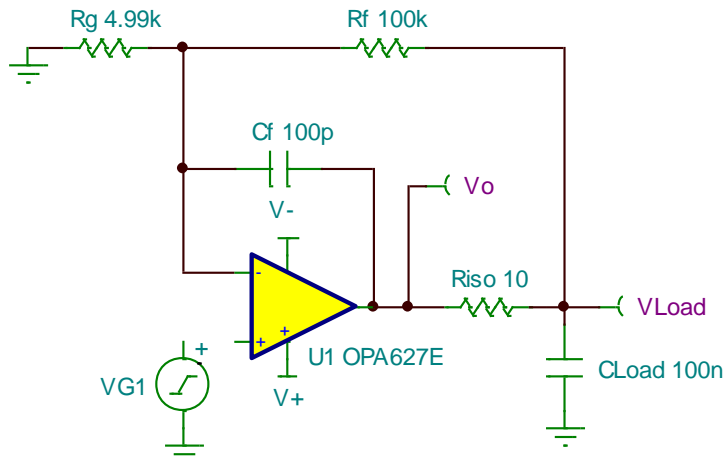

Method 3: C_f

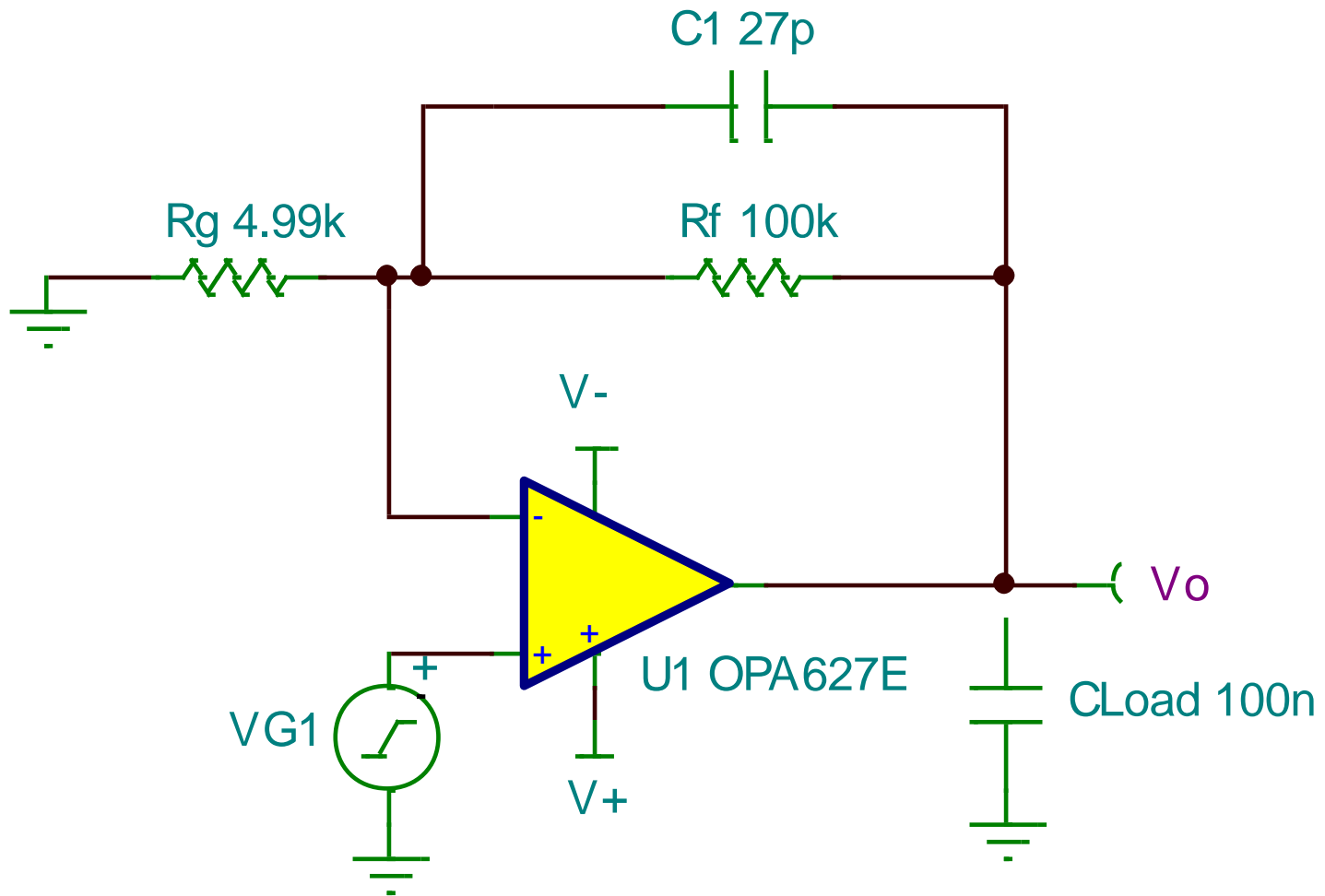

Method 3: Cf - Results

Theory: 1/Beta compensation. Cf feedback capacitor causes 1/Beta to decrease at -20dB/decade and if placed correctly will cause the ROC to be 20dB/decade.

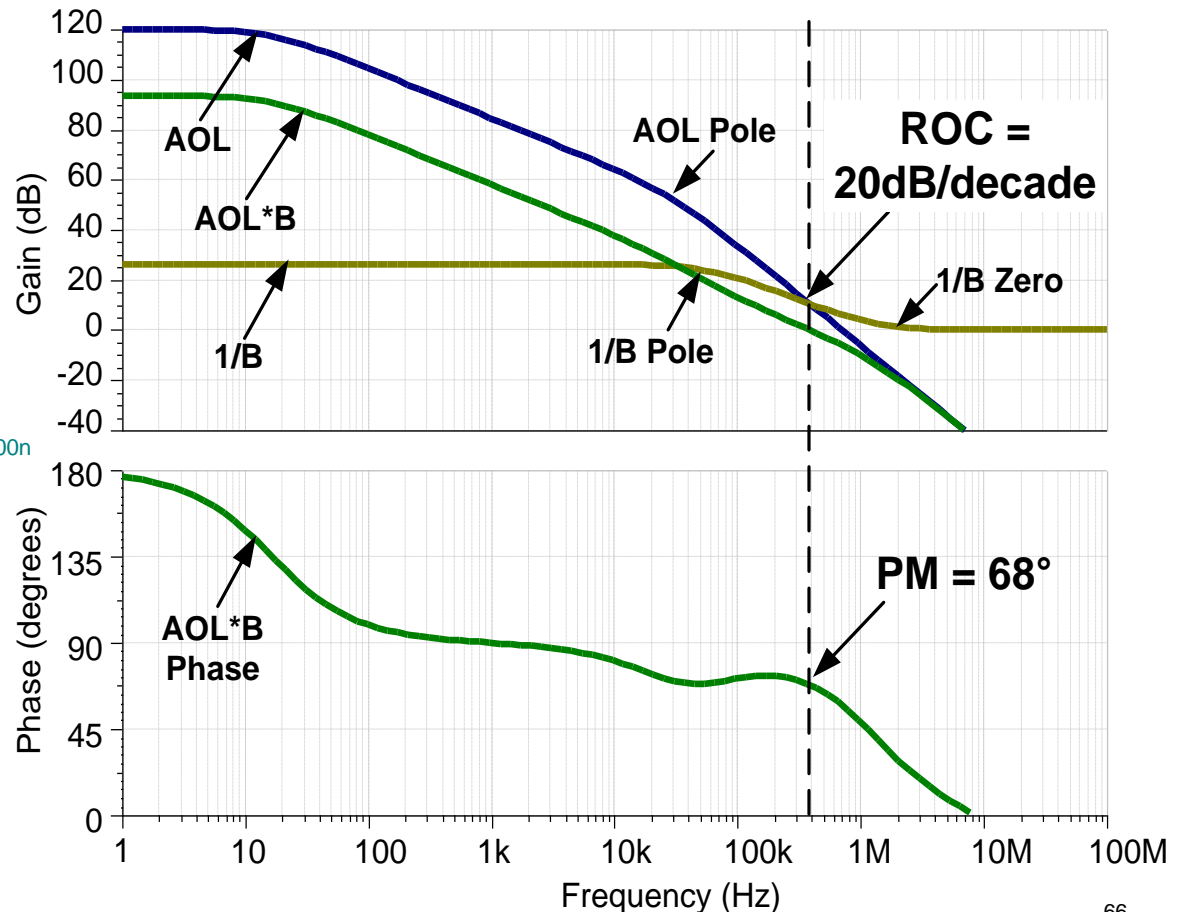
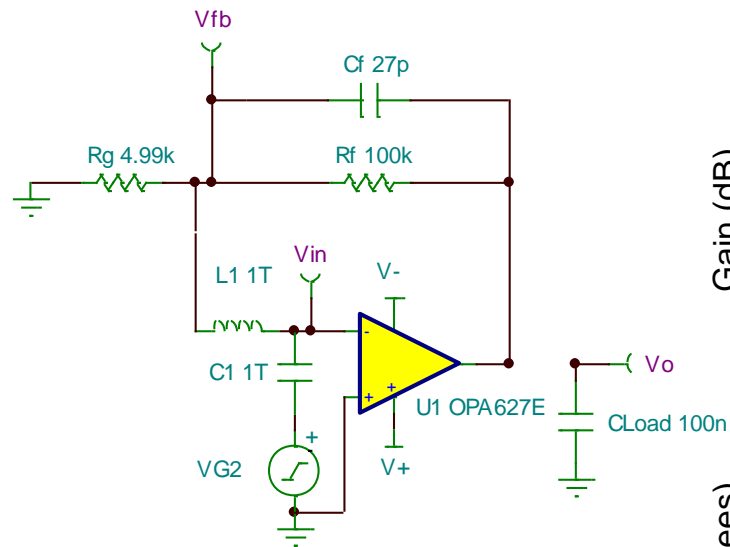

Method 3: Cf - Results

When to use: Especially effective when NG is high, $\geq 30\text{dB}$.

Systems where a bandwidth limitation is not an issue

- Limits closed-loop bandwidth at $1/(2*\pi*Rf*Cf)$

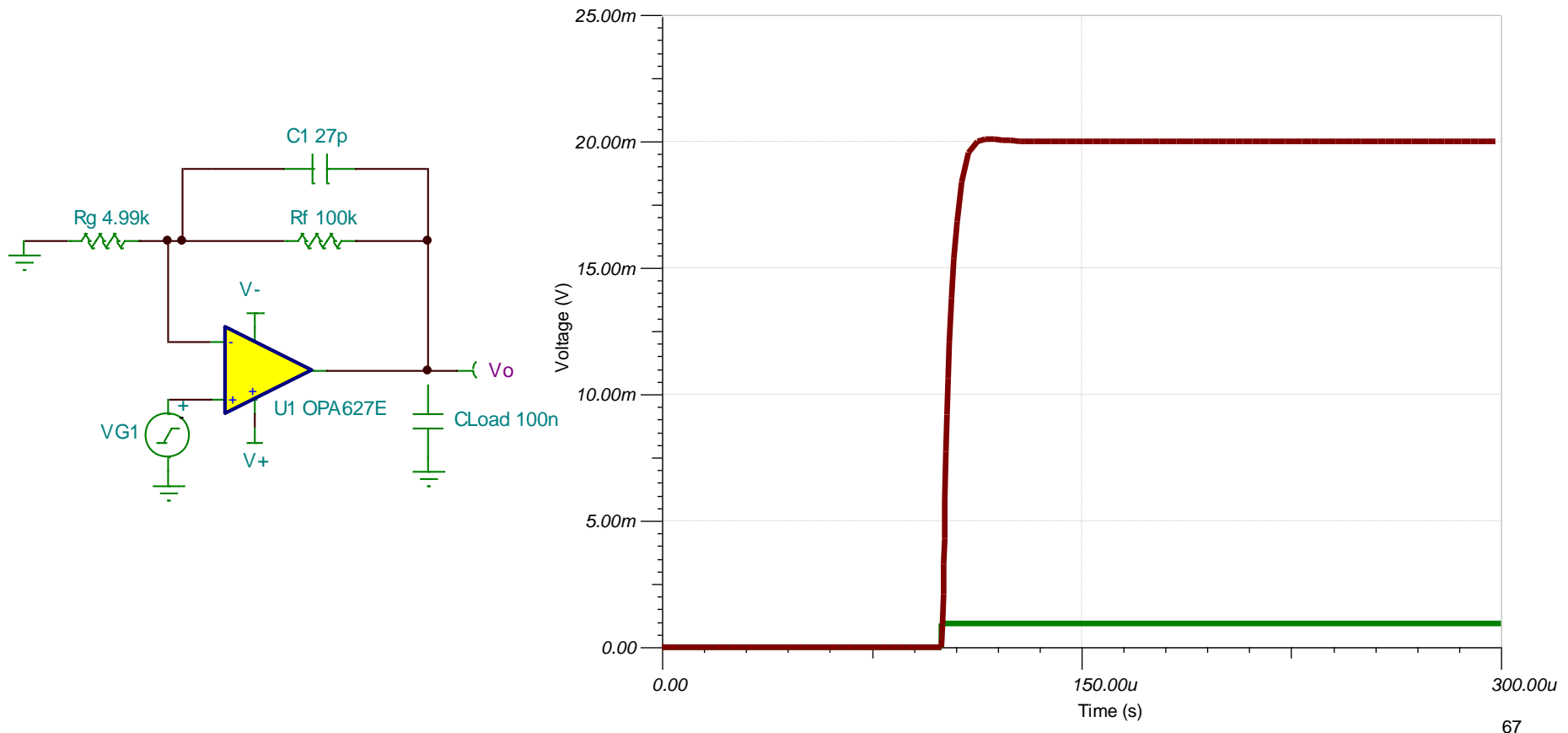

Method 3: Cf - Design

Ensure Good Phase Margin:

For 20dB/decade ROC, 1/Beta must intersect AOL while its slope is -20dB/decade.

Therefore: $f(1/B \text{ pole}) < f(\text{cl_unmodified})$

$f(1/B \text{ zero}) > f(\text{AOL} = 0\text{dB})$

$f(\text{cl_unmodified}) = 152.13\text{kHz}$

$f(\text{AOL} = 0\text{dB}) = 704.06\text{kHz}$

1/B Pole Equation:

$$f(1/B \text{ pole}) = \frac{1}{2 \cdot \pi \cdot R_f \cdot C_f}$$

1/B Zero Equation:

$$f(1/B \text{ zero}) = \frac{1}{2 \cdot \pi \cdot (R_g \parallel R_f) \cdot C_f}$$

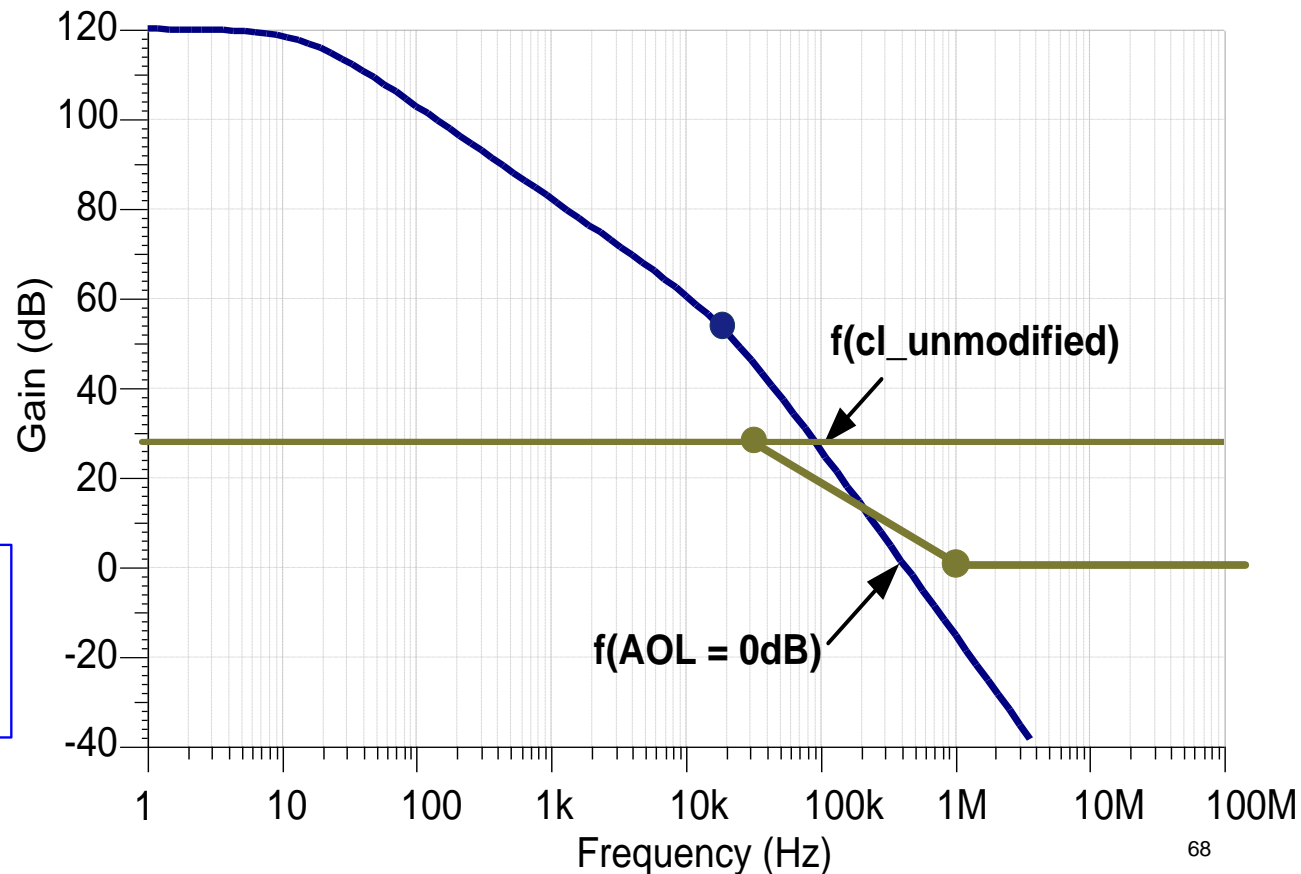

Method 3: Cf - Design

Ensure Good Phase Margin:

- 1.) Find $f(\text{AOL}=0\text{dB})$
- 2.) Set $f(1/B \text{ zero})$ by choosing C_f :

Good: Set $f(1/B \text{ zero}) = f(\text{AOL} = 0\text{dB})$ for $\text{PM} \approx 45$ degrees.

Better: Set $f(1/B \text{ zero})$ so $\text{AOL} @ f(\text{cl}) = \frac{1}{2}$ Low-Frequency NG in dB

$f(\text{AOL} = 0\text{dB}) = 704.06\text{kHz}$

1/B Zero Equation:

$$f(1/B \text{ zero}) = \frac{1}{2 \cdot \pi \cdot (R_g \parallel R_f) \cdot C_f}$$

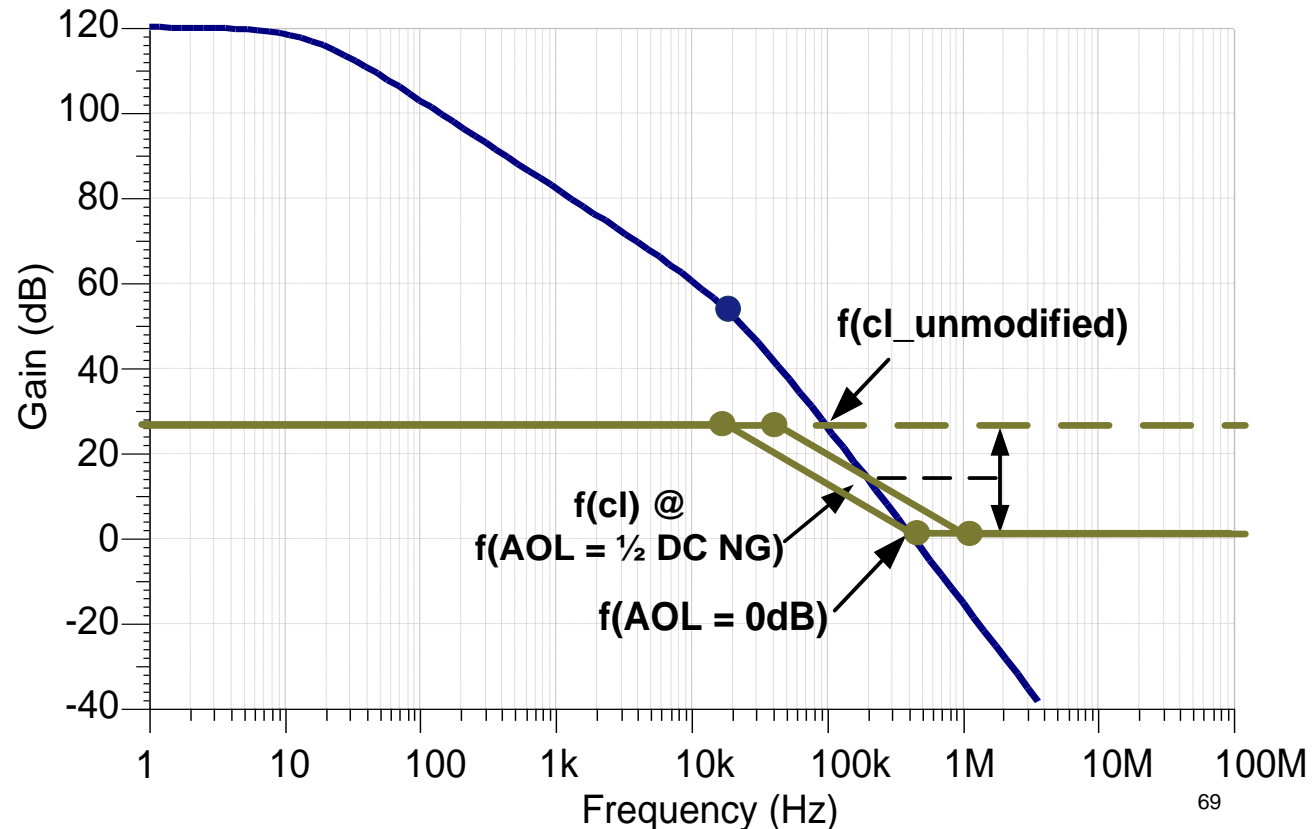

Method 3: Cf – Design - Summary

Summary:

- 1.) Ensure stability by placing:
 - a) $f(1/B \text{ zero}) \geq f(\text{AOL} = 0\text{dB})$
 - b) $f(1/B \text{ pole}) \leq f(\text{cl_unmodified})$
- 2.) Try to adjust the zero location so the 1/B curve crosses the AOL curve in the middle of the 1/B span allowing for shifts in AOL

Final Circuit

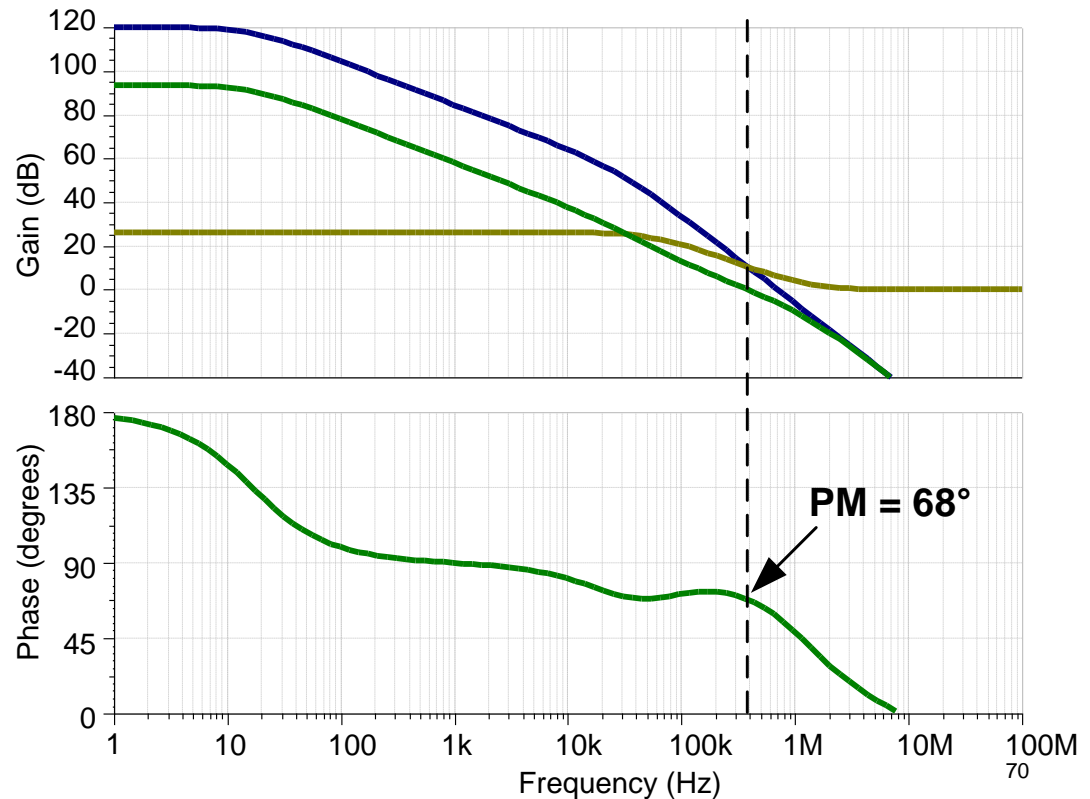
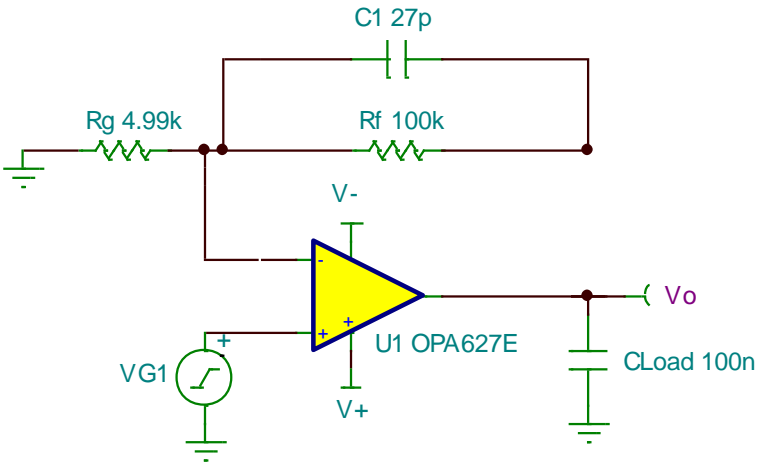

Method 4: Noise-Gain

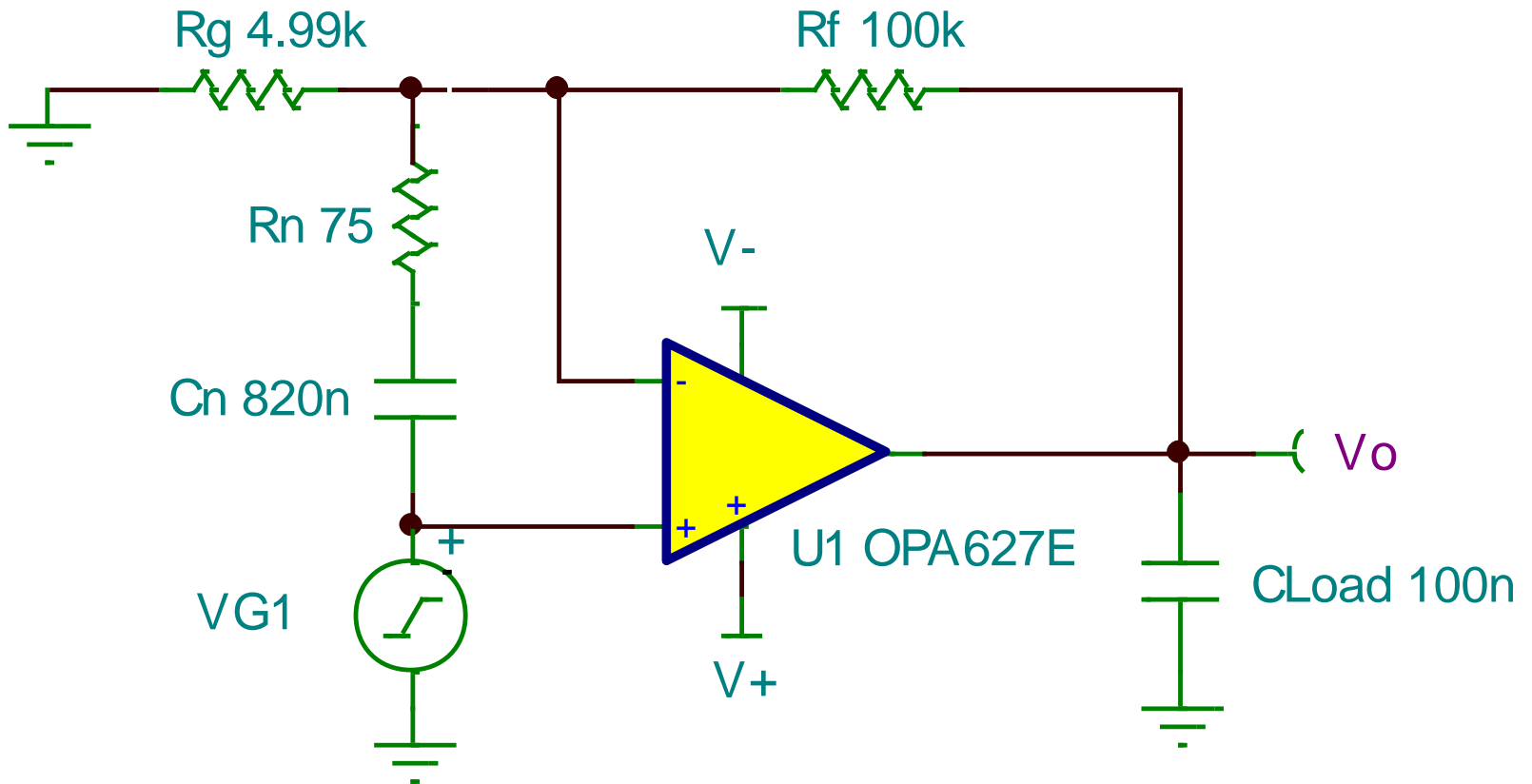

Method 4: Noise Gain - Results

Theory: 1/Beta compensation. Raise high-frequency 1/Beta so the ROC occurs before the AOL pole causes the AOL slope to change

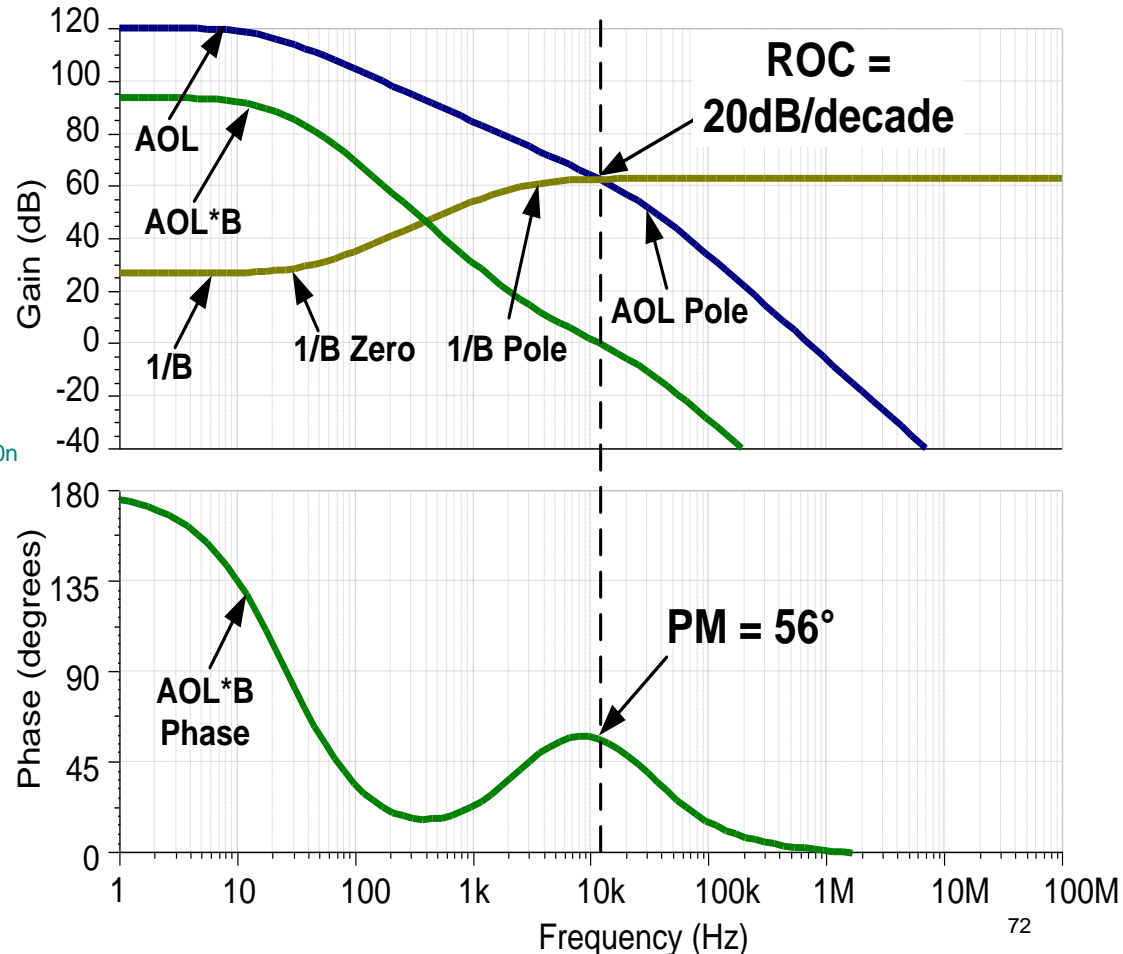
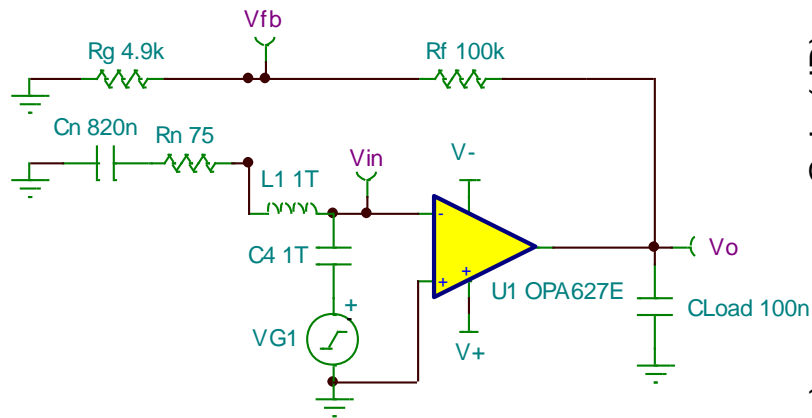

Method 4: Noise Gain - Results

When to use: Better for lighter capacitive loading

When AOL @ f(AOL pole) < (Closed loop gain + 20dB)

Due to the increase in noise gain, this approach may not be practical when required noise gain is greater than the low-frequency signal gain by more than ~25-30dB.

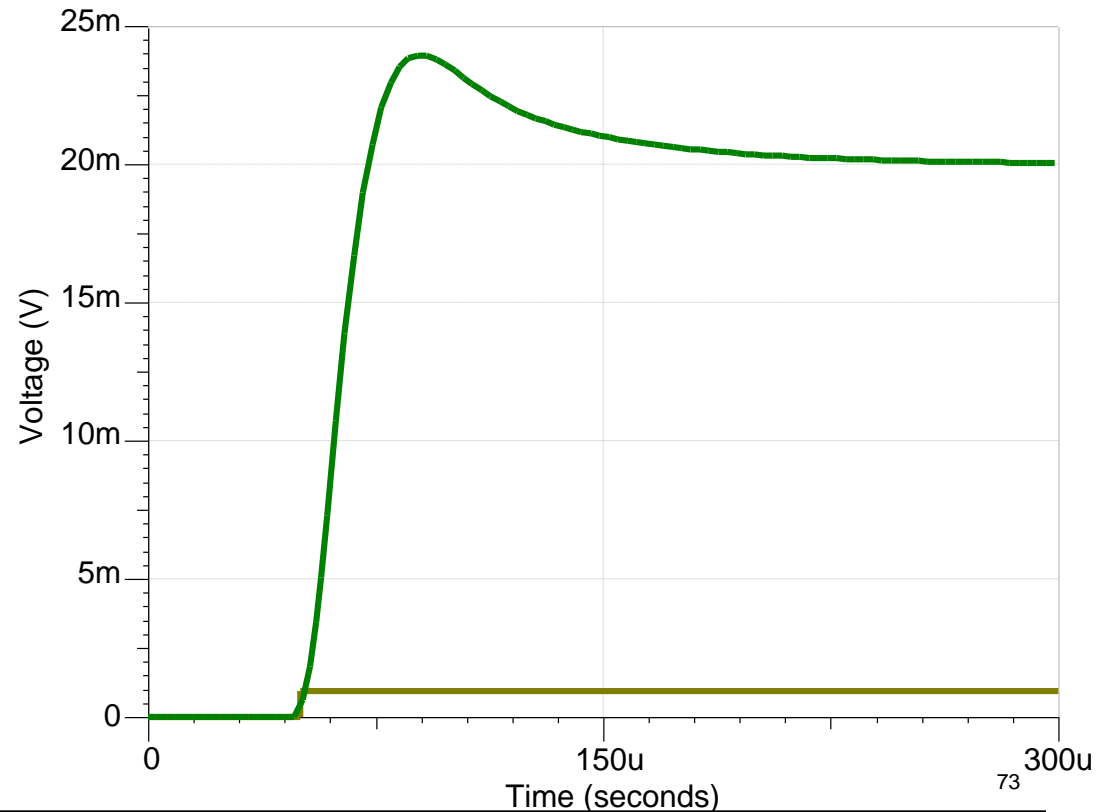
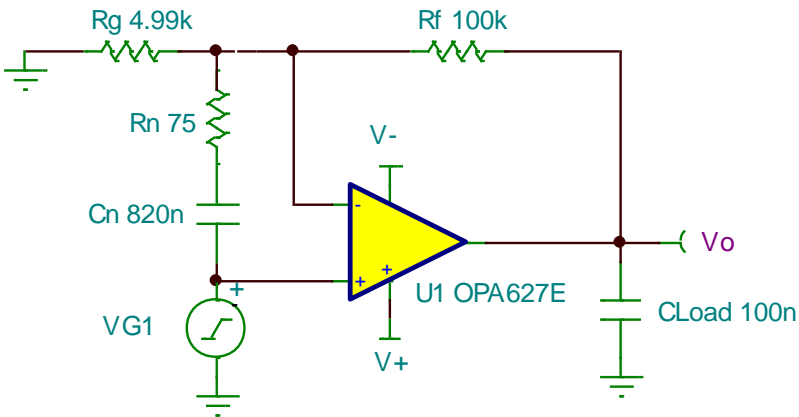

Method 4: Noise Gain - Design

Ensure Good Phase Margin:

For 20dB/decade ROC, 1/Beta must intersect AOL above the AOL pole.

Therefore: |High-Freq NG| > |AOL| @ f(AOL pole)

f(1/B zero) < f(AOL = High-Freq NG)

|AOL| @ f(AOL pole) = 52.11dB

f(AOL pole) = 29.49kHz

High-Freq Noise-Gain Equation:

$$\text{HF NG} = \frac{R_f}{(R_g \parallel R_n)}$$

1/B Zero Equation:

$$f(1/B \text{ zero}) = \frac{1}{2 \cdot \pi \cdot R_n \cdot C_n}$$

1/B Pole Equation:

$$f(1/B \text{ pole}) = \frac{1}{2 \cdot \pi \cdot (R_n + (R_g \parallel R_f)) \cdot C_f}$$

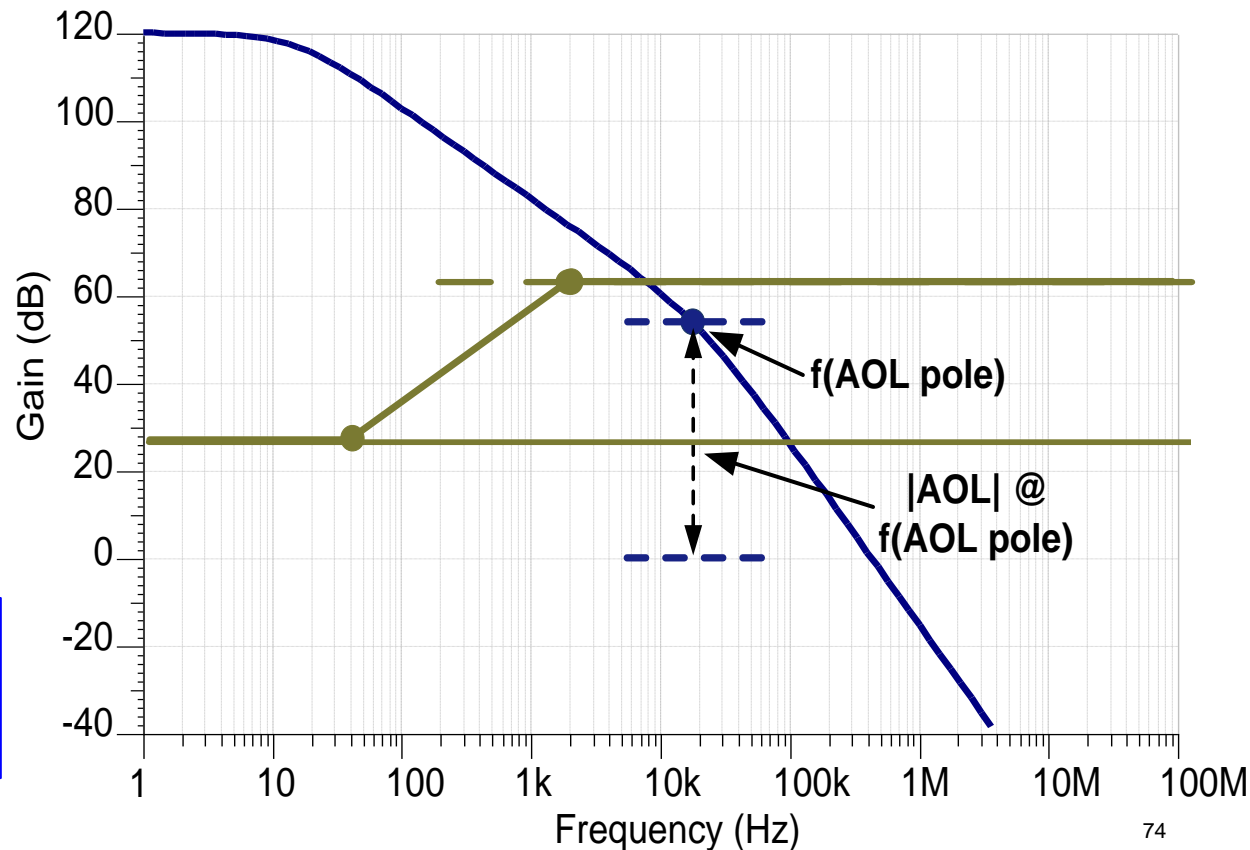

Method 4: Noise Gain - Design

Ensure Good Phase Margin:

- 1.) Find $f(\text{AOL pole})$ and $|\text{AOL}| @ f(\text{AOL pole})$
- 2.) Set High-Freq Noise-Gain by choosing R_n :
 - Good: $|\text{HF NG}| \geq |\text{AOL}| @ f(\text{AOL pole})$
 - Better: $|\text{HF NG}| \geq |\text{AOL}| @ f(\text{AOL pole}) + 10\text{dB}$

$|\text{AOL}| @ f(\text{AOL pole}) = 52.11\text{dB}$

$f(\text{AOL pole}) = 29.49\text{kHz}$

High-Freq Noise-Gain Equation:

$$\text{HF NG} = \frac{R_f}{(R_g \parallel R_n)}$$

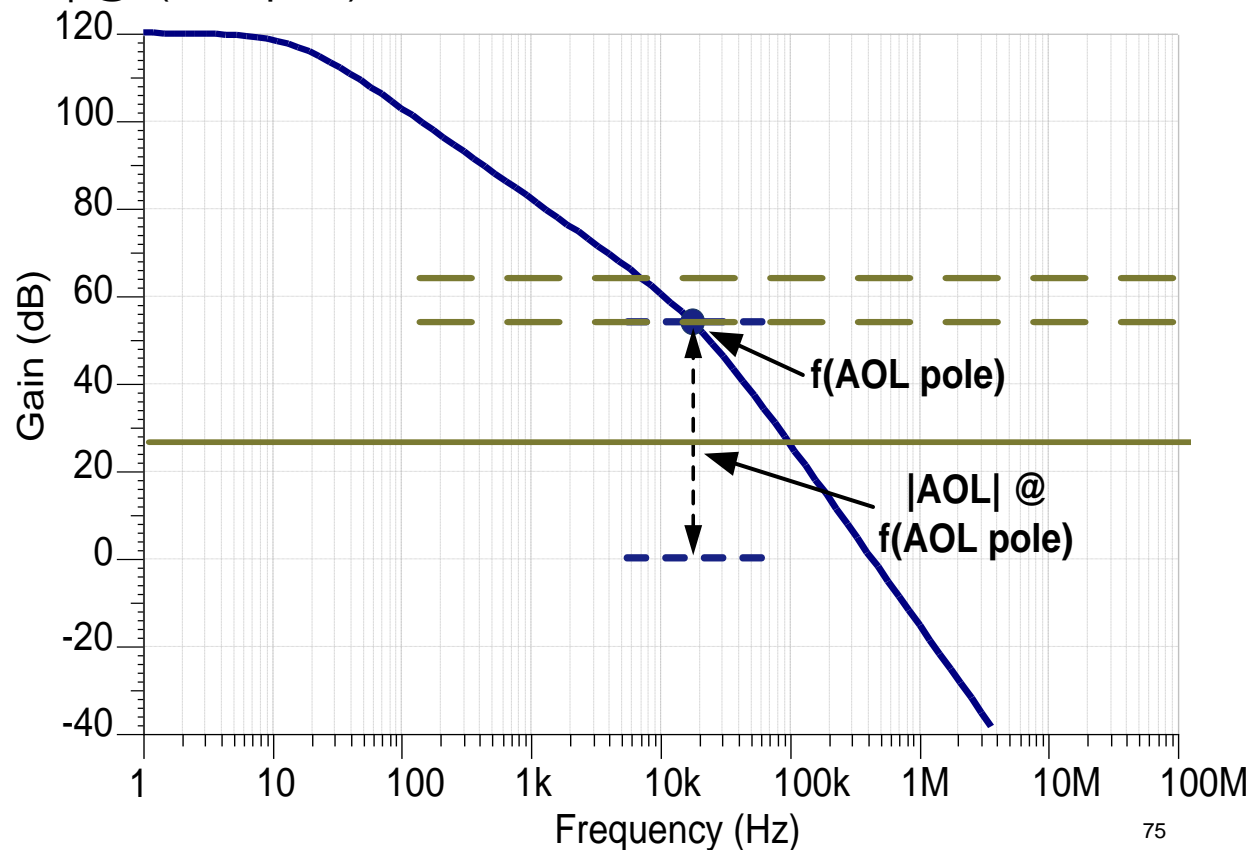

Method 4: Noise Gain - Design

Ensure Good Phase Margin:

3.) Find $f(\text{cl_modified}) = f(\text{AOL} @ |\text{HF NG}|)$

4.) Set $f(1/B \text{ zero})$ by choosing C_n :

Good: $f(1/B \text{ zero}) \leq f(\text{cl_modified})$

Better: $f(1/B \text{ zero}) \leq f(\text{cl_modified}) / 3.5$ ($\sim 1/2$ decade)

$f(\text{cl_modified}) = 29.49\text{kHz}$

High-Freq Noise-Gain Equation:

$$\text{HF NG} = \frac{R_f}{(R_g || R_n)}$$

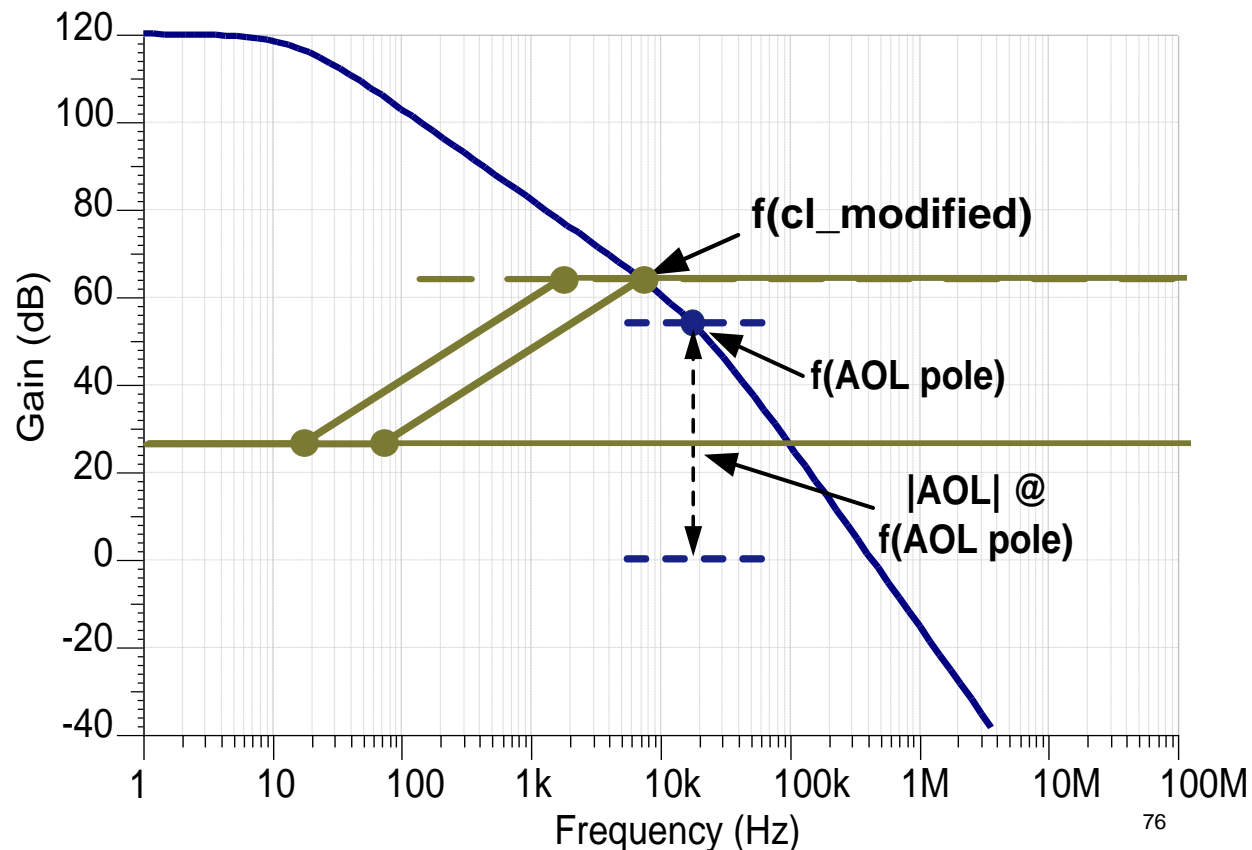

Method 4: Noise Gain - Summary

Summary:

- 1.) Ensure stability by setting:
 - a) $|HF\ NG| \geq (|AOL| @ f(AOL\ pole) + 10dB)$
 - b) $f(1/B\ zero) \leq f(cl_modified) / 3.5$

Final Circuit

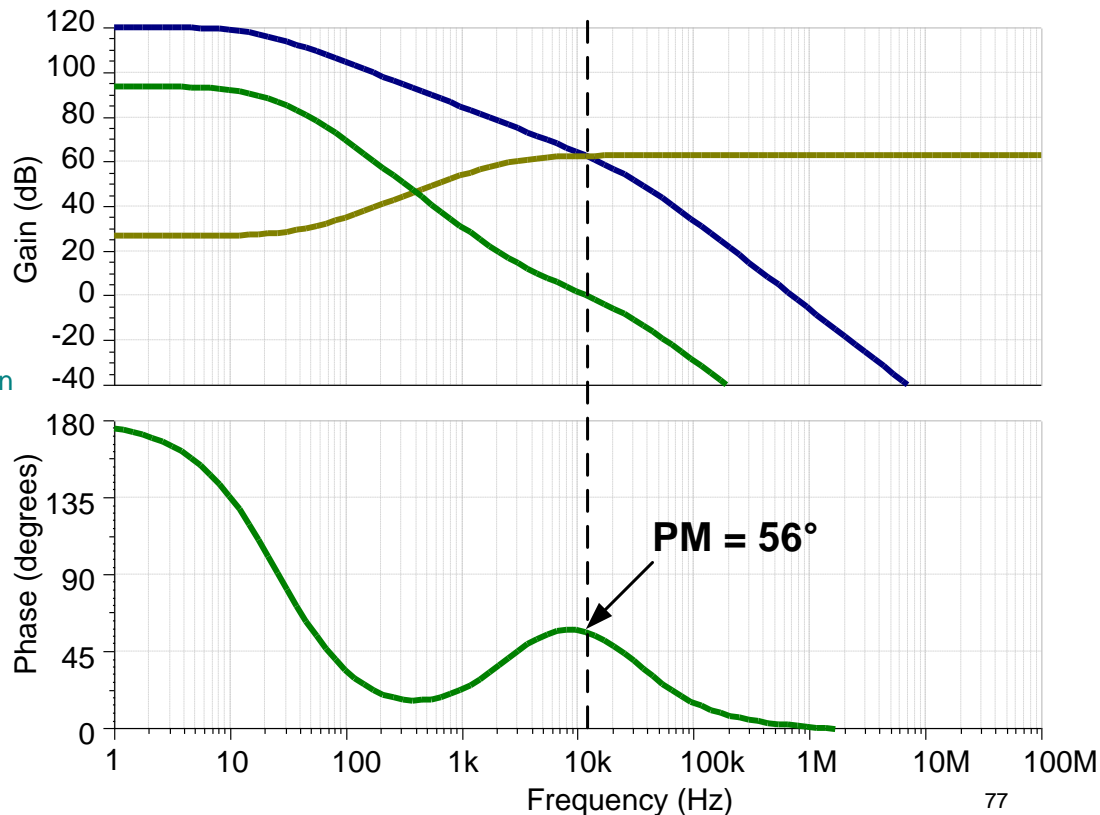
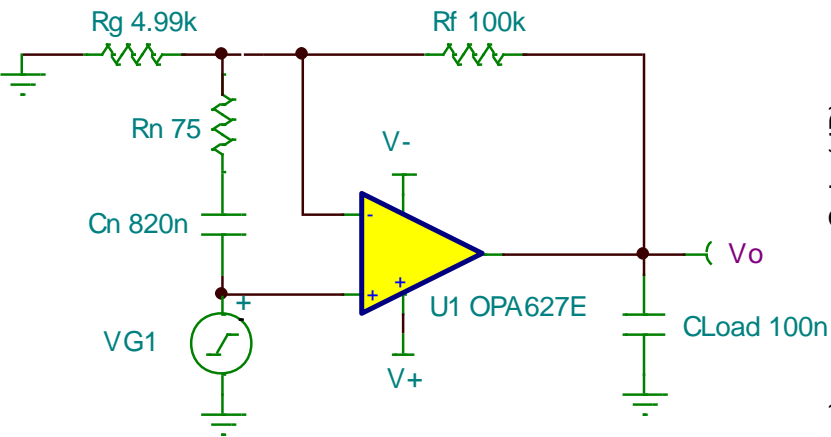

Method 4: Noise Gain

Quick reminder that inverting and non-inverting noise gain circuits are different!

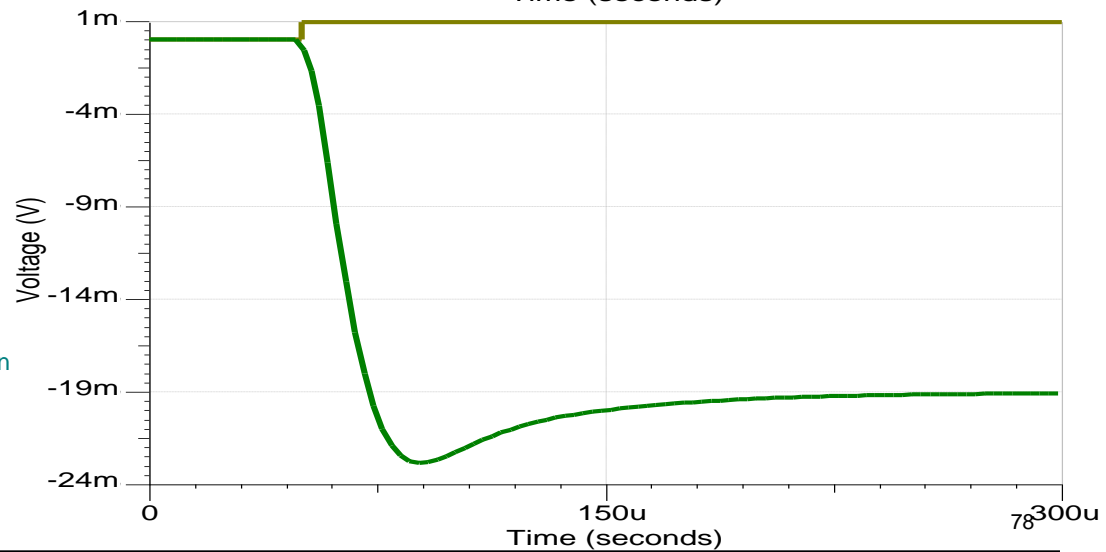
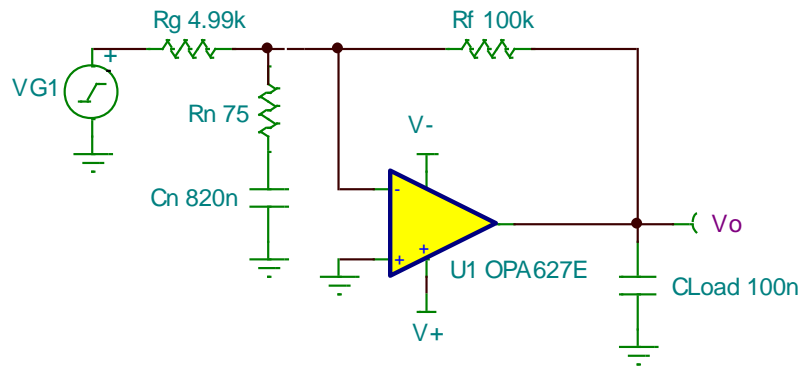
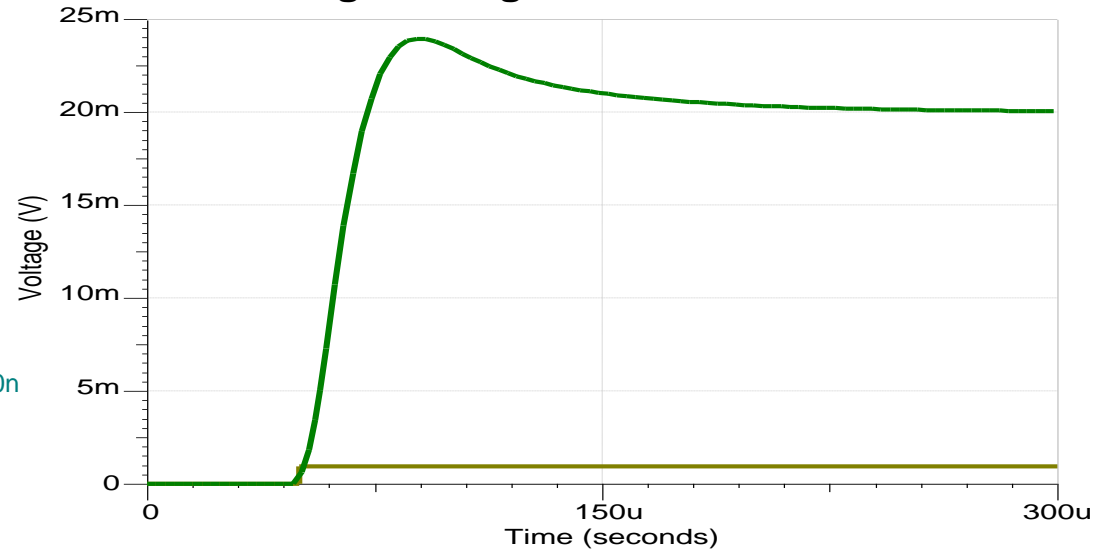
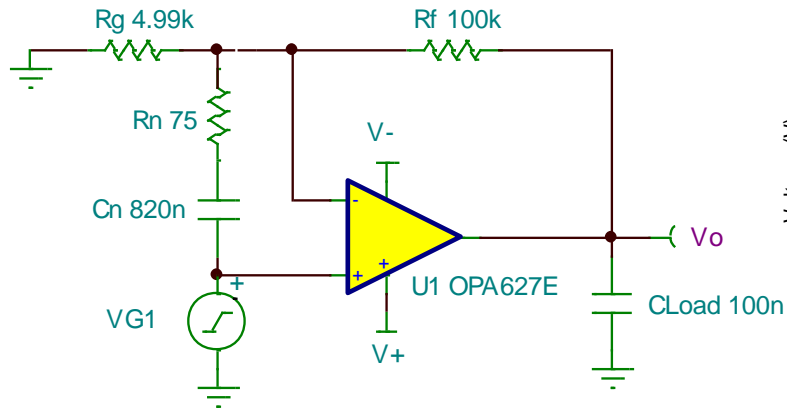

Circuits with High Feedback Network Impedance

Circuits with High Feedback Network Impedance

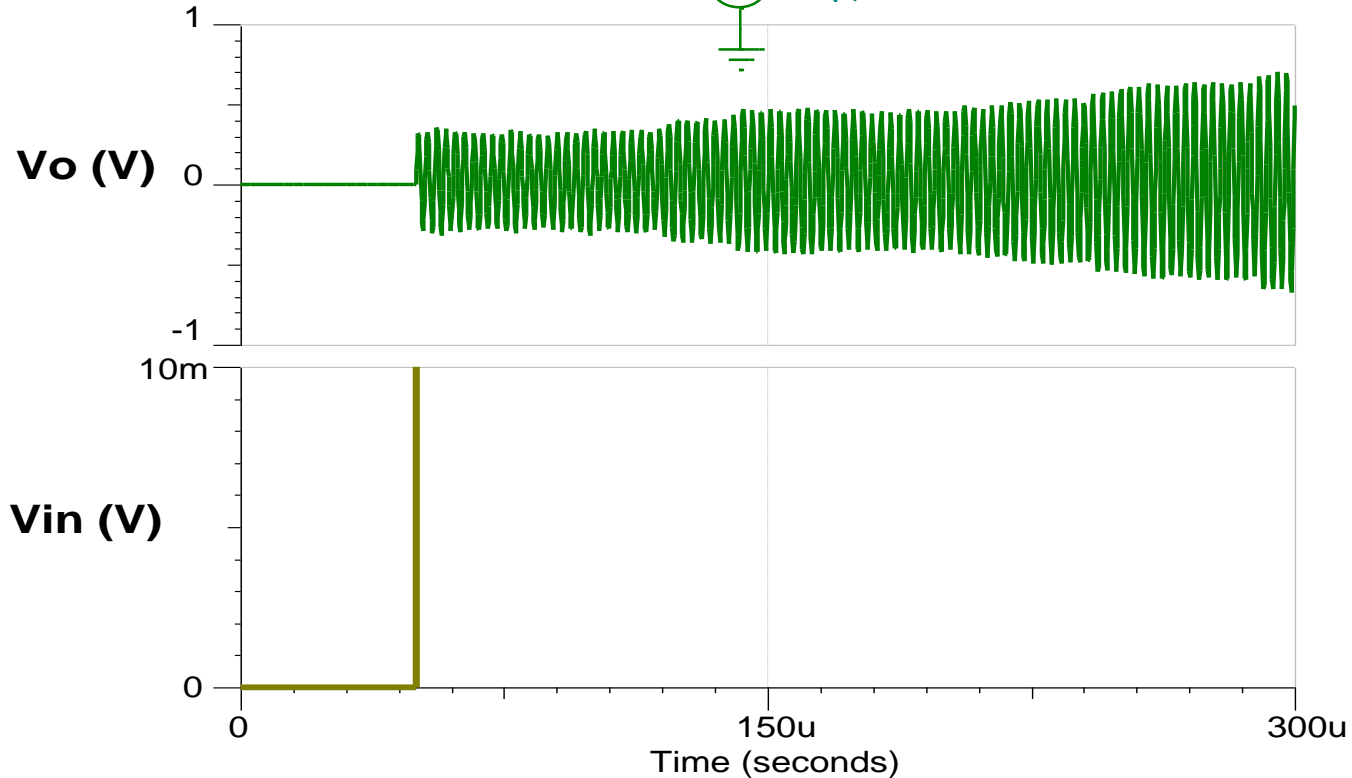
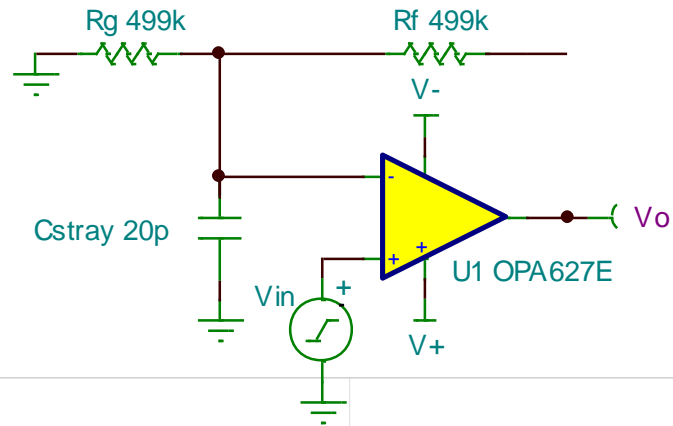

Circuits with High Feedback Network Impedance

Determine the issue:

Zero in 1/Beta!!

ROC = 40dB/decade!!

Phase Margin 2!!

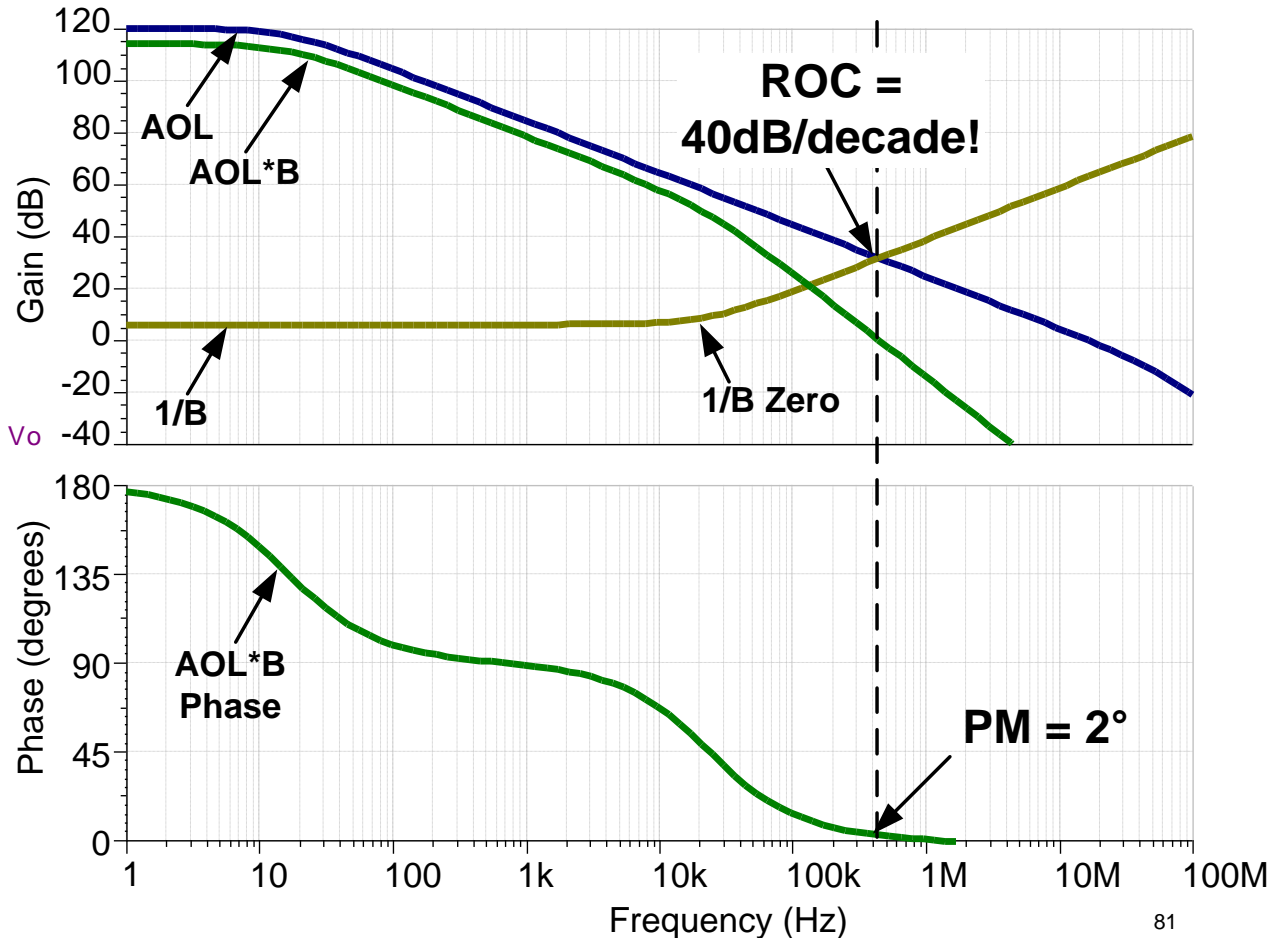
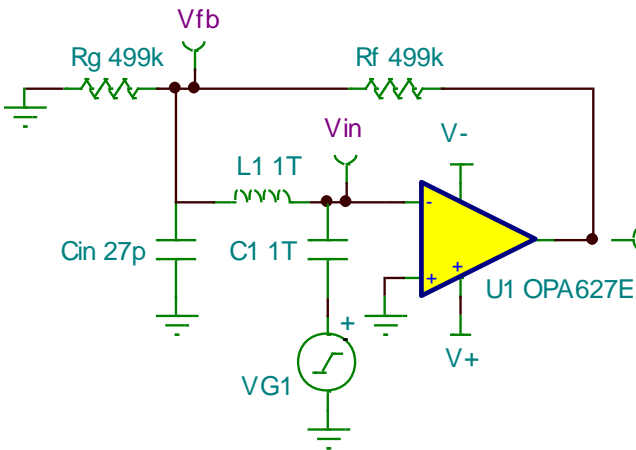

Circuits with High Feedback Network Impedance - Theory

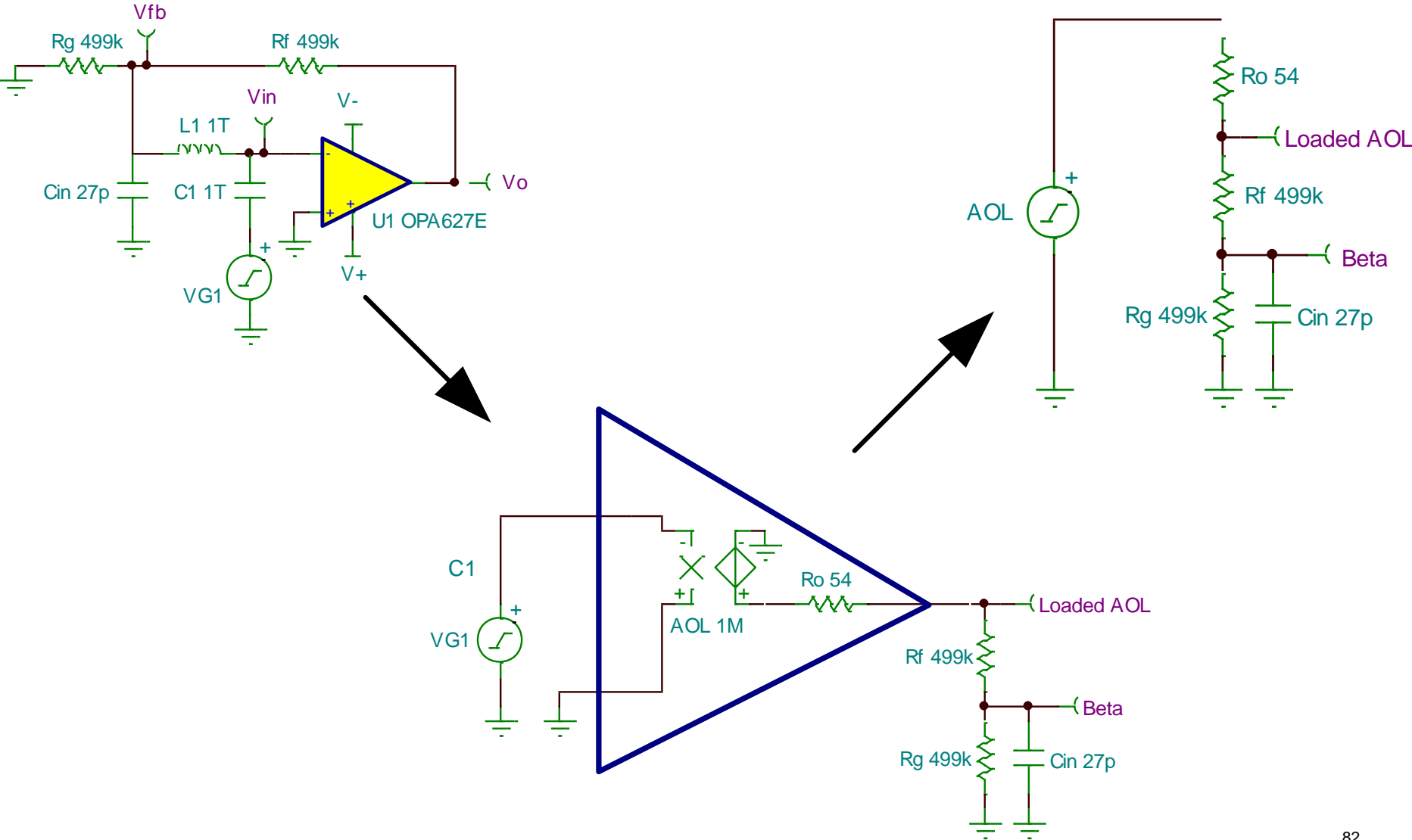

Circuits with High Feedback Network Impedance - Theory

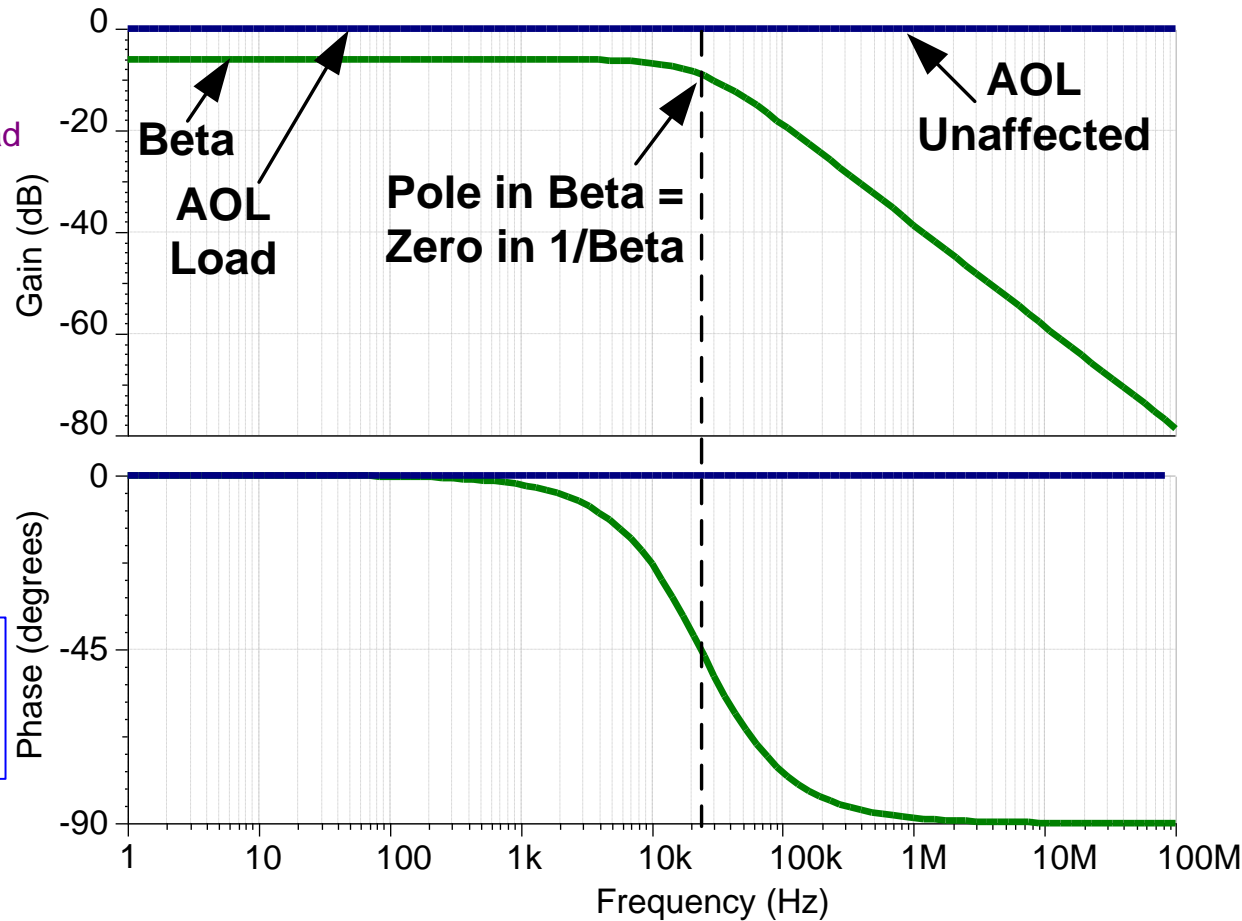
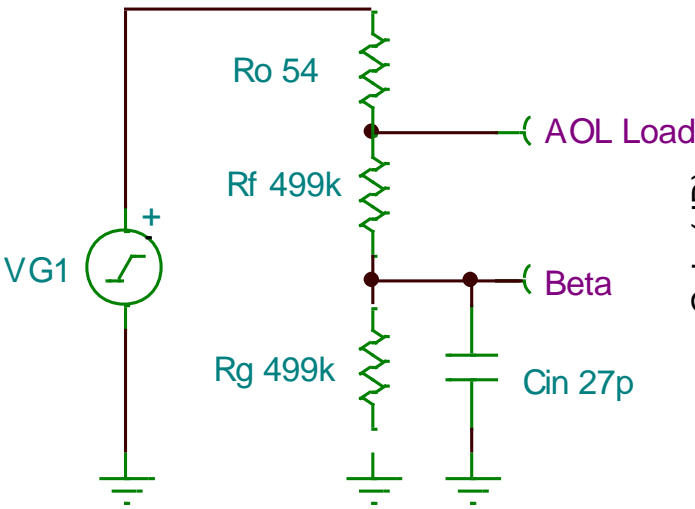

Beta Pole & 1/Beta Zero Equation:

$$f(B \text{ pole}) = f(1/B \text{ zero}) = \frac{1}{2 \cdot \pi \cdot (R_g \parallel R_f) \cdot C_{in}}$$

Stabilize Circuits With High Feedback Network Impedance

Stability Options – Zero in 1/Beta

The only practical option is to add a pole to cancel the 1/Beta Zero

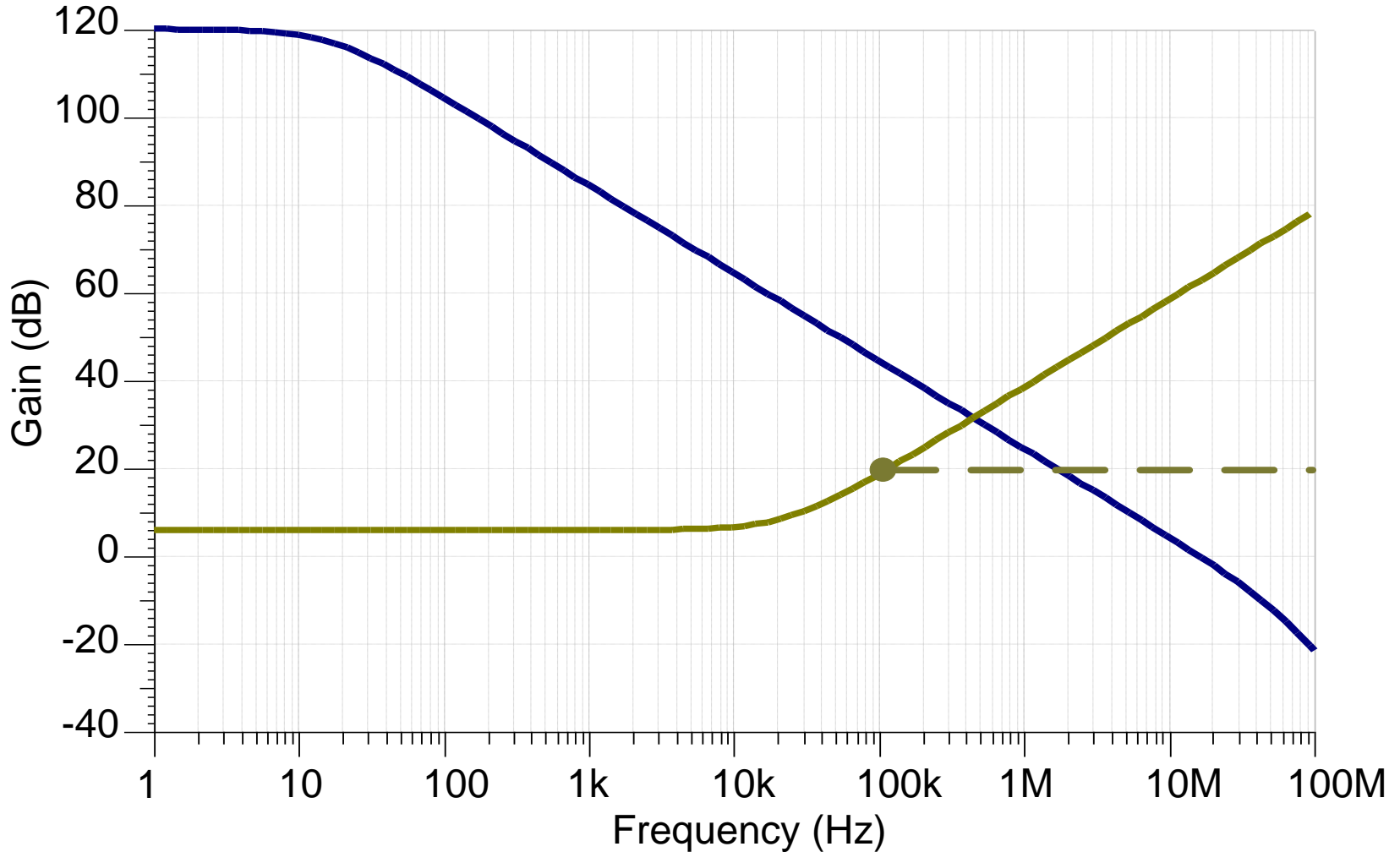

Method 1: C_f

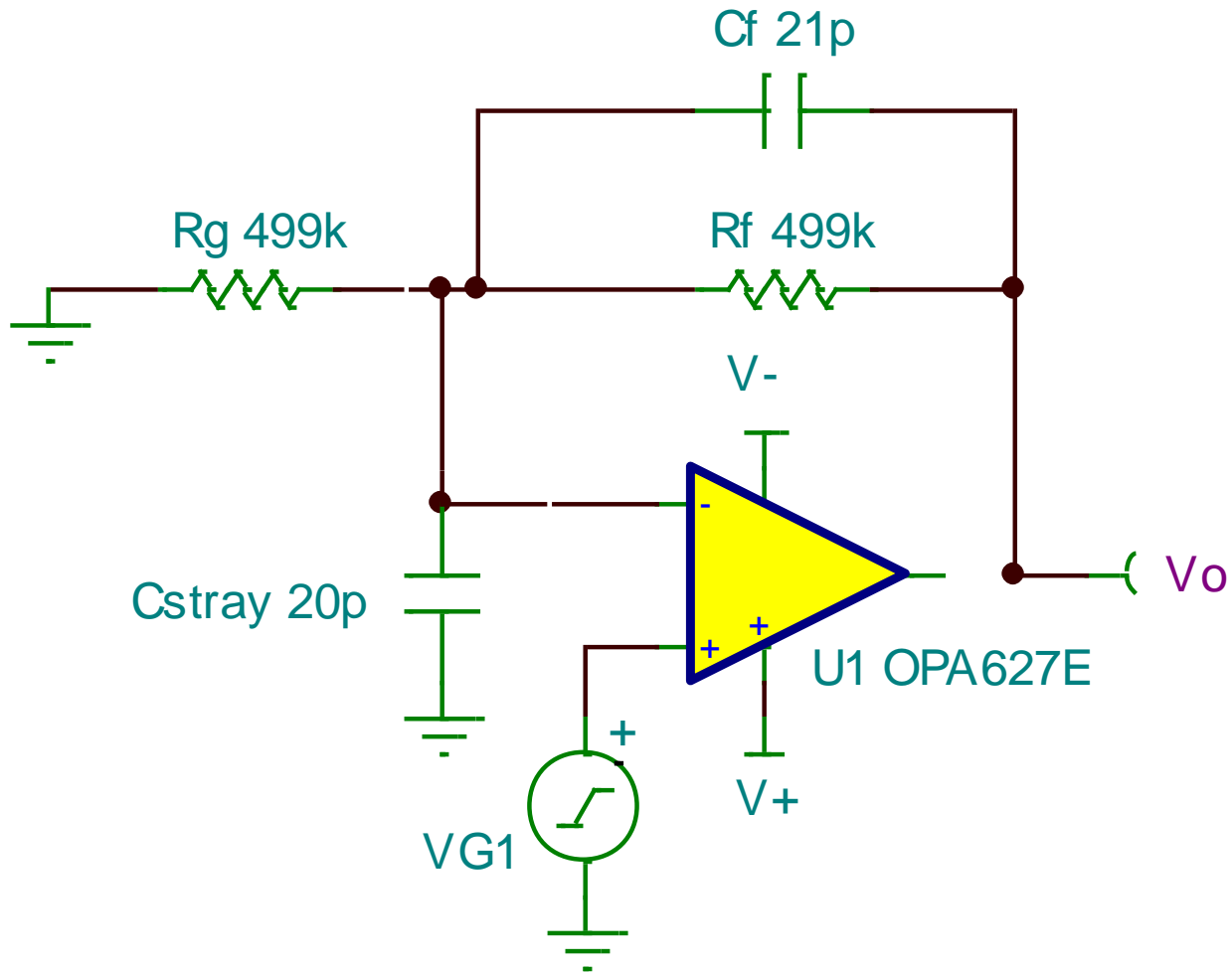

Method 1: Cf - Results

Theory: 1/Beta compensation. Cf feedback places a pole in 1/Beta to cancel the zero from the input capacitance.

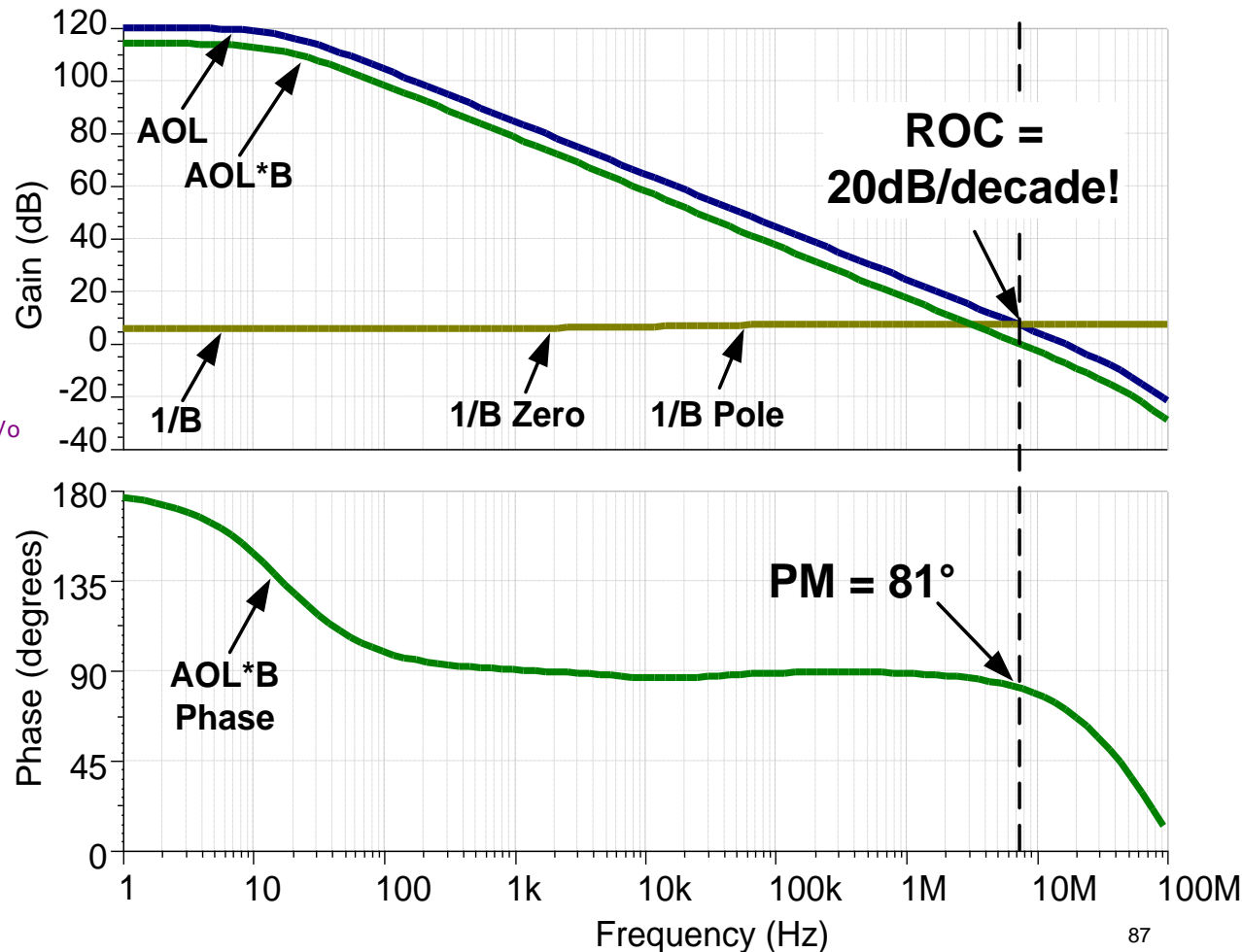
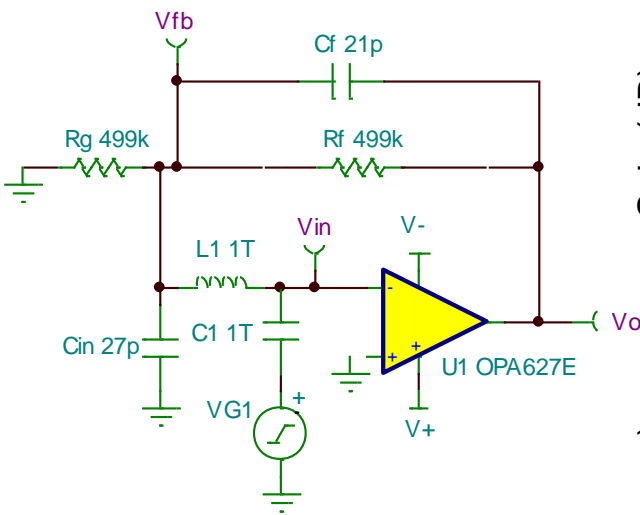

Method 1: Cf - Results

When to use: Almost always a safe design practice.
Limits gain at $1/(2\pi R_f C_f)$

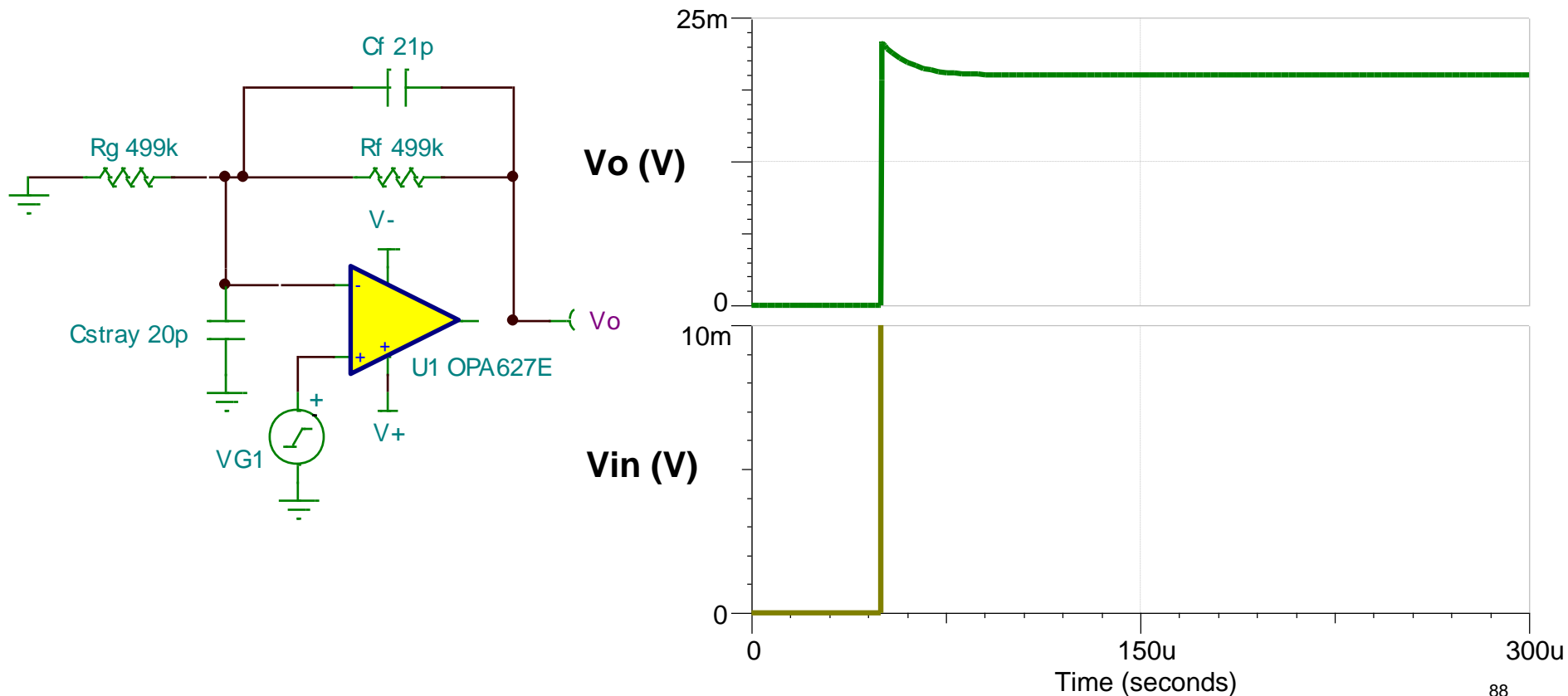

Method 1: Cf - Design

Ensure Good Phase Margin:

For 20dB/decade ROC, the 1/Beta pole must flatten the 1/Beta Zero before f(cl)

Therefore $f(1/\text{Beta pole}) \leq f(\text{cl})$

$$f(\text{cl}) = 445.6\text{kHz}$$

1/B Pole Equation:

$$f(1/B \text{ pole}) = \frac{1}{2 \cdot \pi \cdot R_f \cdot C_f}$$

1/B Zero Equation:

$$f(1/B \text{ zero}) = \frac{1}{2 \cdot \pi \cdot (R_g \parallel R_f) \cdot C_{in}}$$

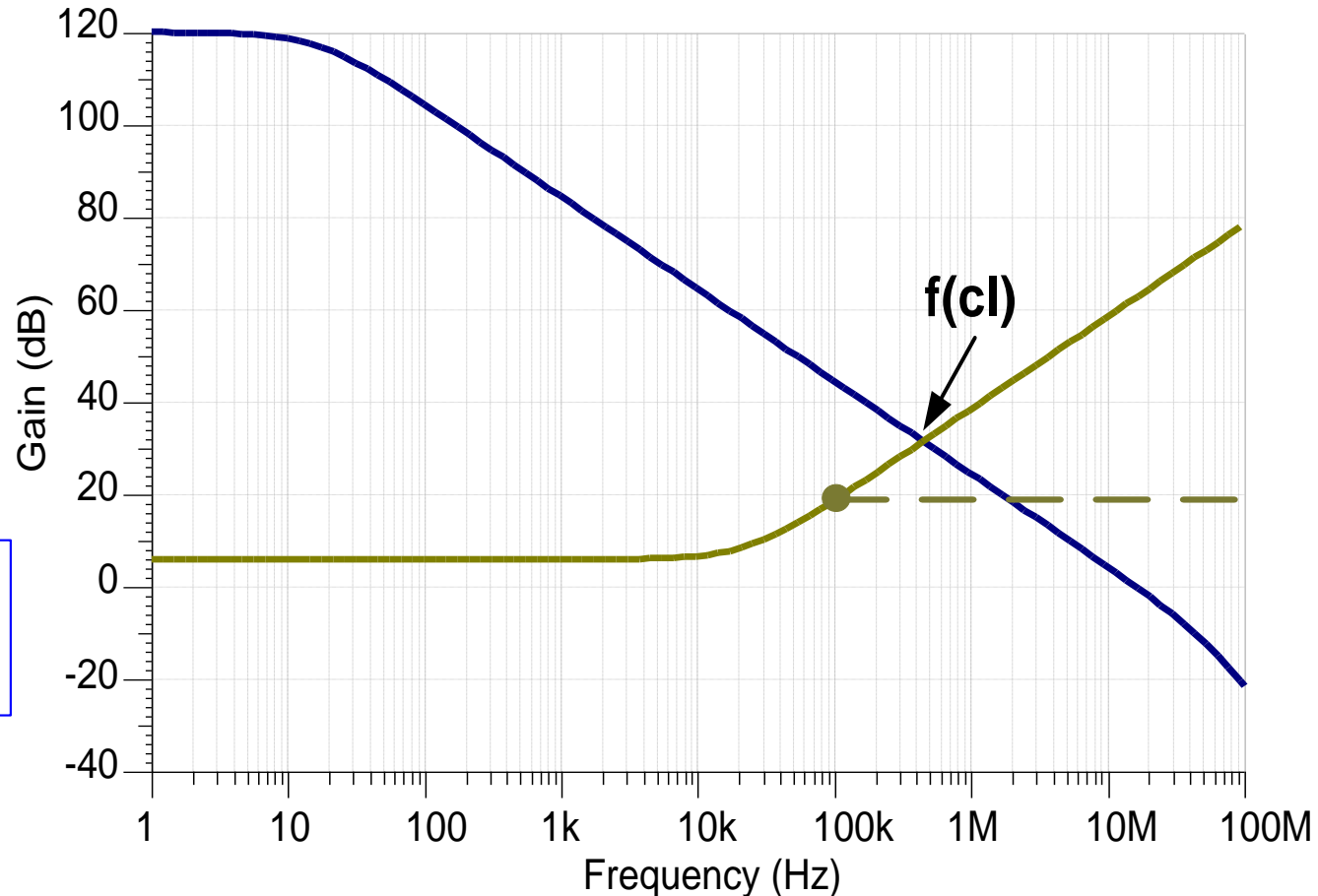

Method 1: Cf - Design

Ensure Good Phase Margin:

- 1.) Find $f(c_l)$
- 2.) Set $f(1/B \text{ pole})$ by setting C_f :
 - Good: $f(1/B \text{ pole}) \leq f(c_l)$
 - Better: $f(1/B \text{ pole}) \leq f(c_l) / 3.5$ ($\sim 1/2$ decade)

1/B Pole Equation:
$$f(1/B \text{ pole}) = \frac{1}{2 \cdot \pi \cdot R_f \cdot C_f}$$

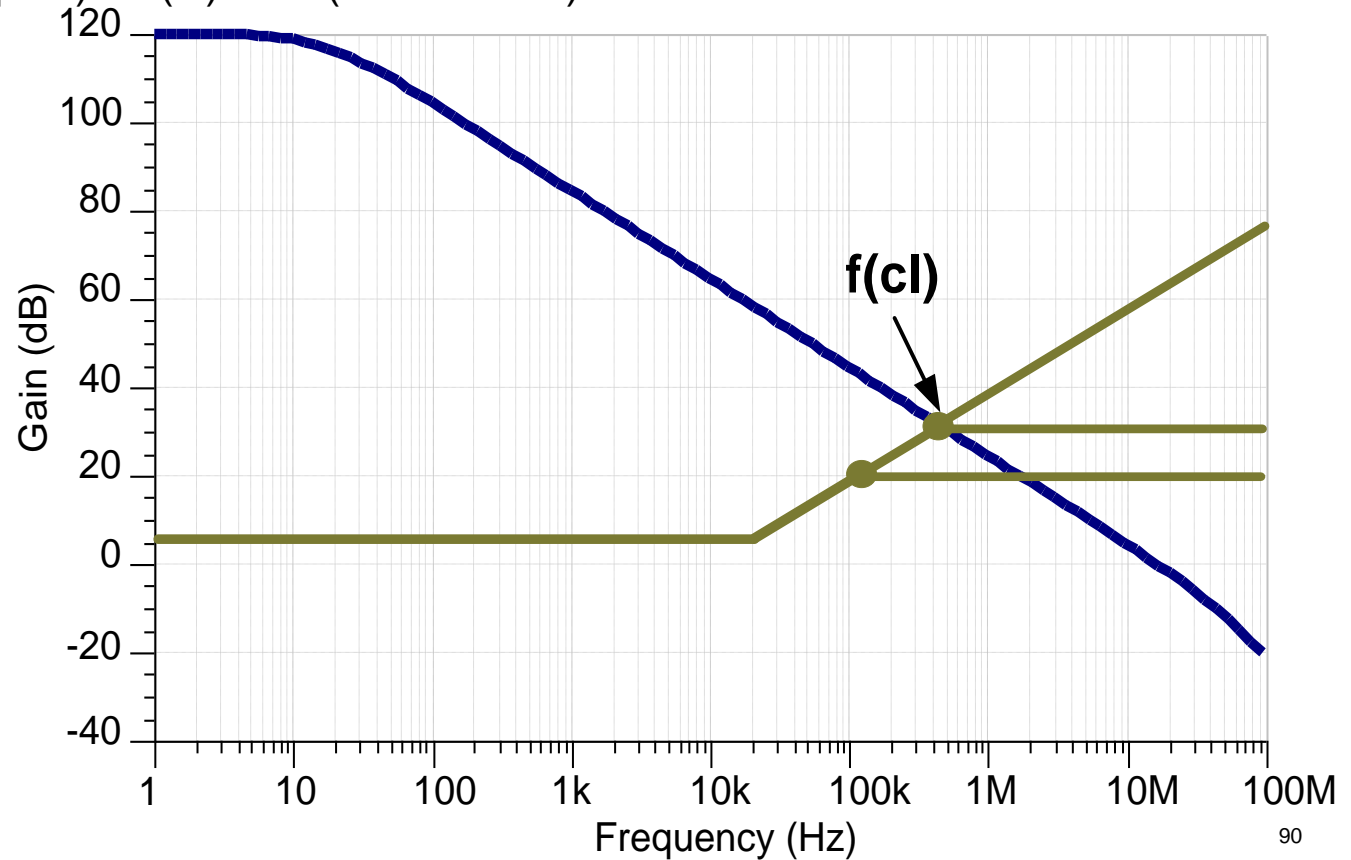

Method 1: Cf - Summary

Summary:

1.) Ensure stability by setting $f(1/B \text{ pole}) \leq f(c_l) / 3.5$ ($\sim 1/2$ decade)

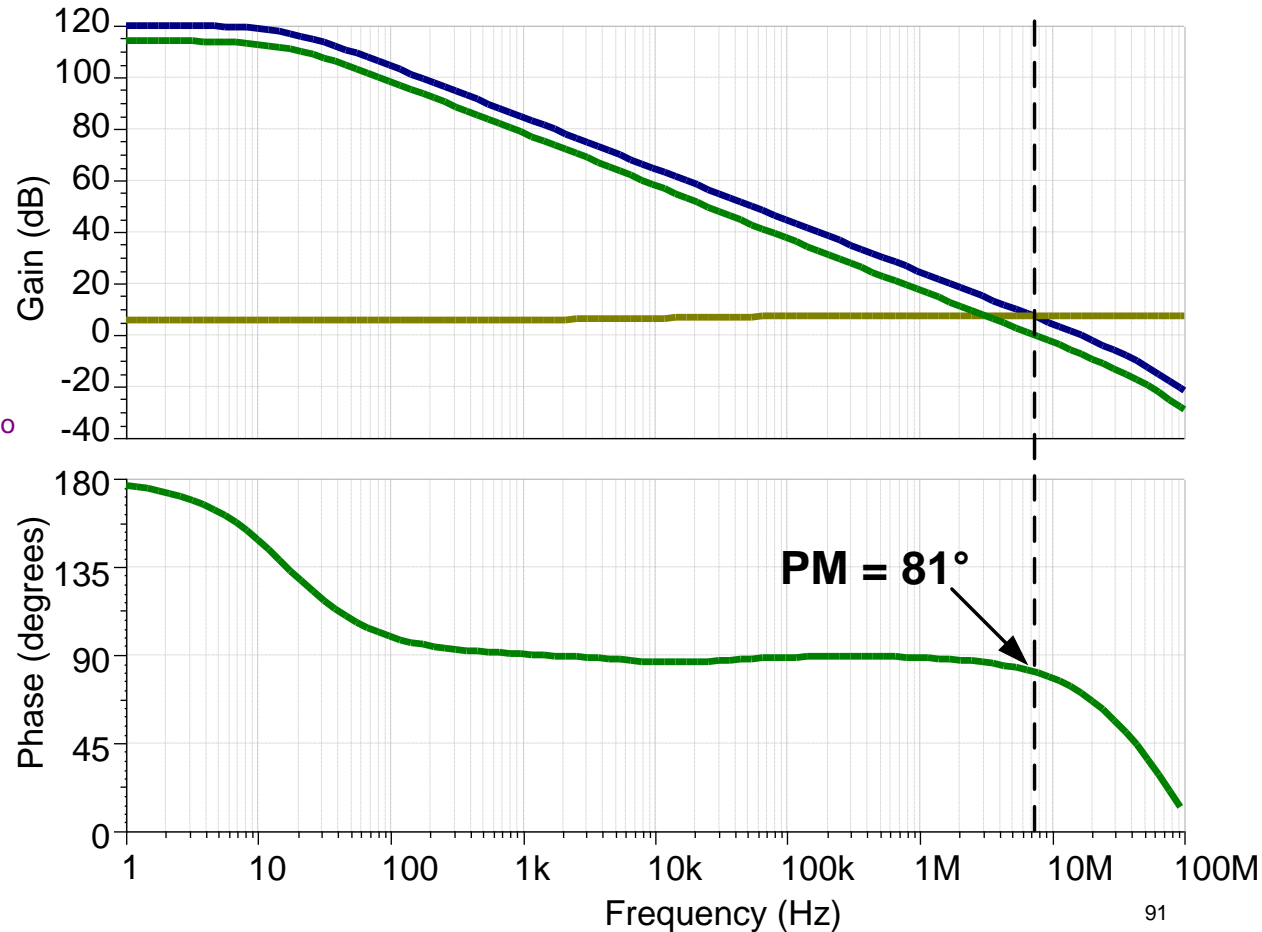
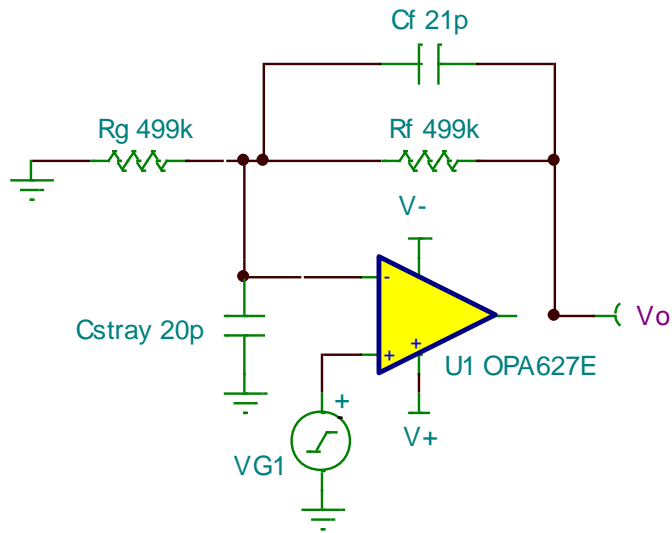

Ro vs. Zo

When Ro is really Zo!!

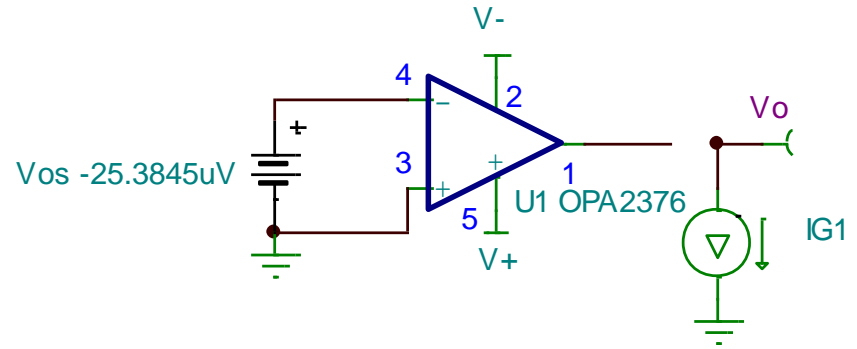
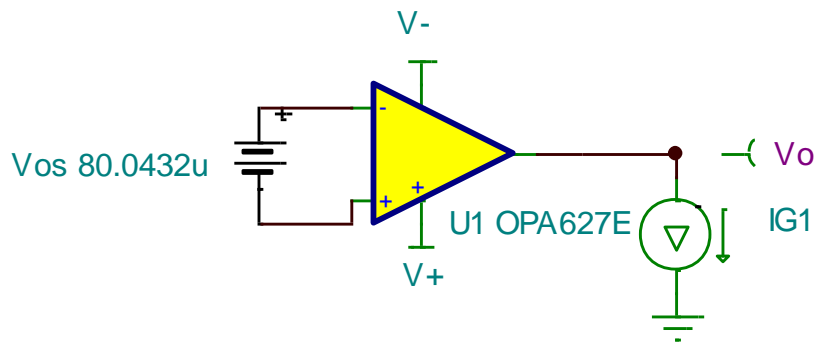

OPEN-LOOP OUTPUT IMPEDANCE vs FREQUENCY

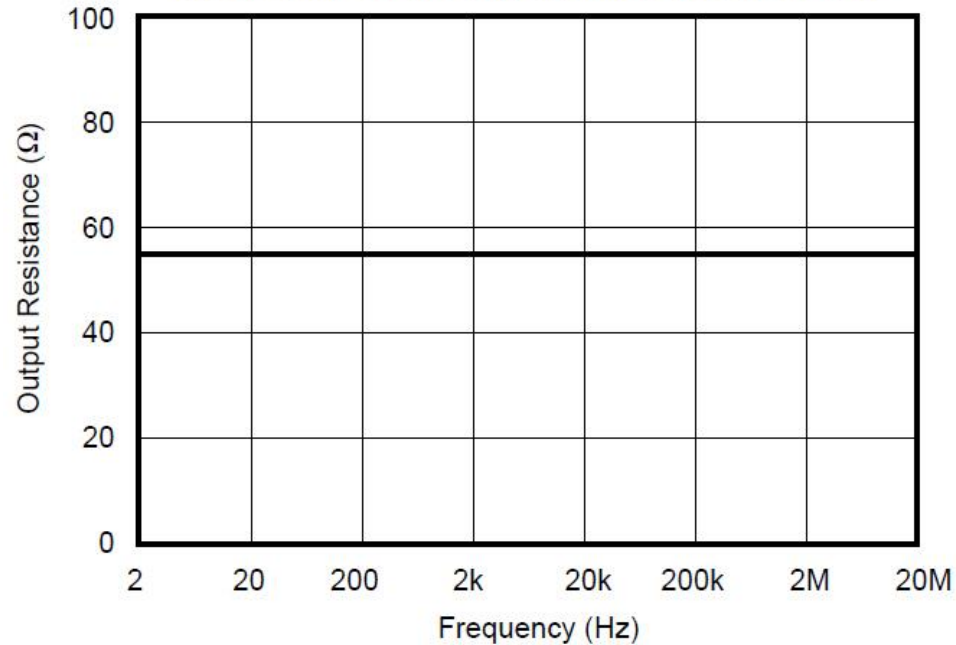

OPEN-LOOP OUTPUT RESISTANCE vs FREQUENCY

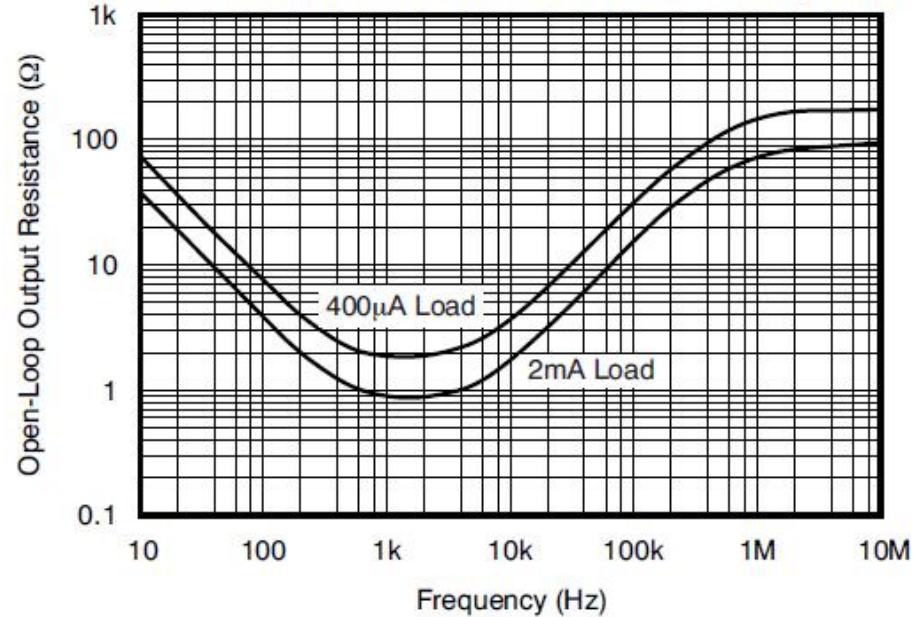

With Complex Zo, Accurate Models are Key!

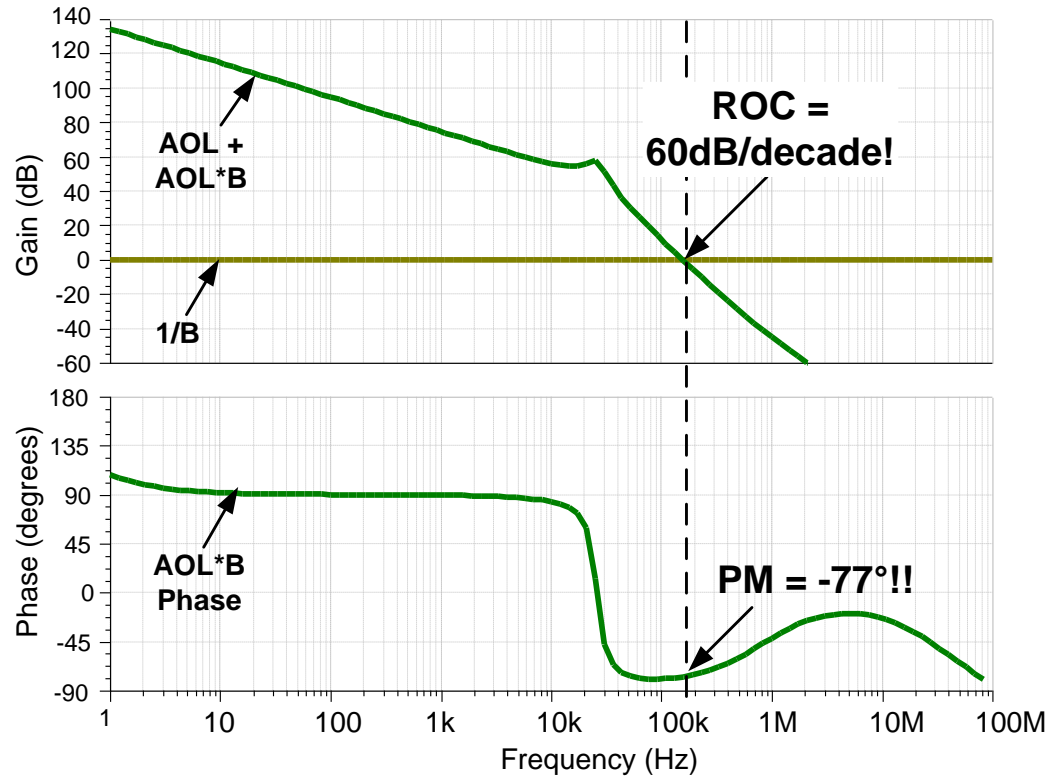
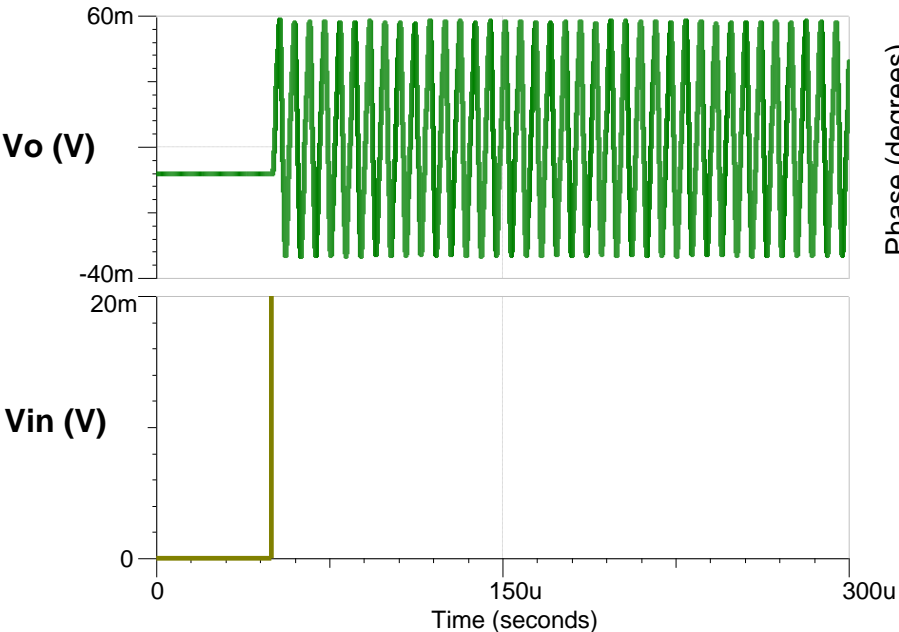
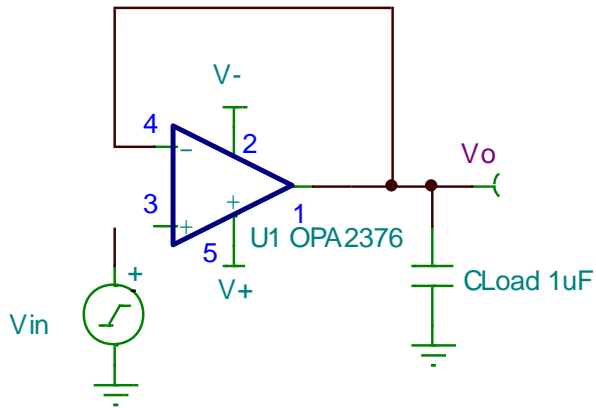

With Complex Zo, Accurate Models are Key!

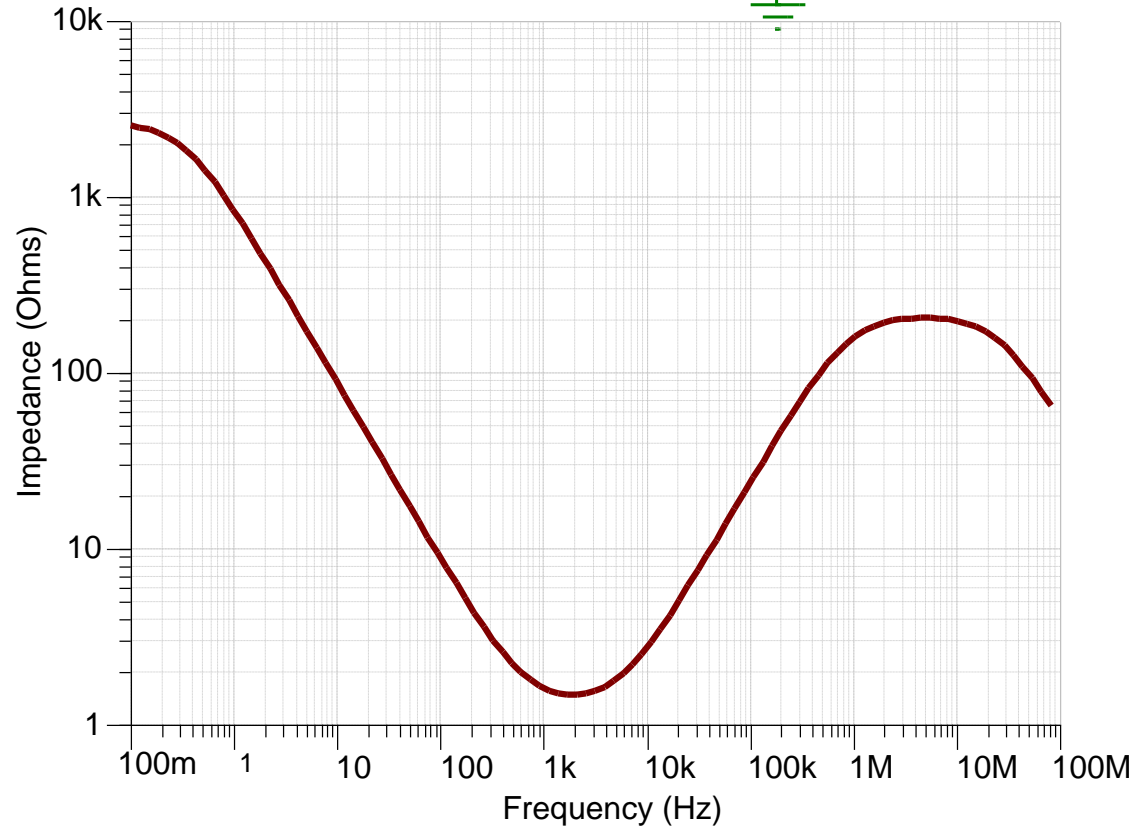
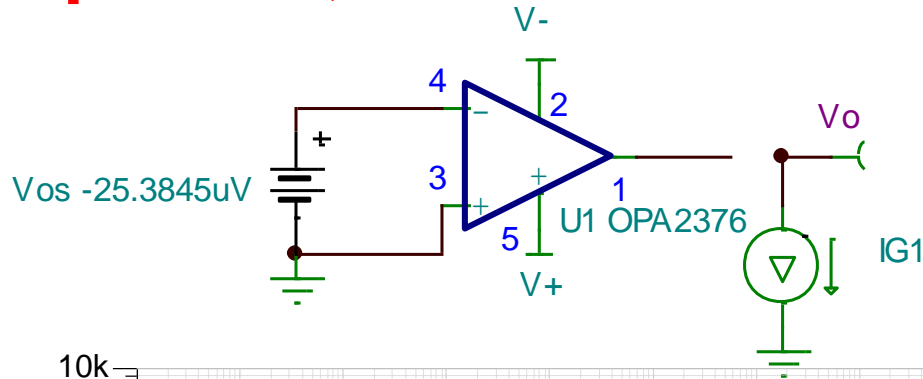

Questions/Comments?

Thank you!!

Special Thanks to:

Art Kay

Bruce Trump

Marek Lis

Tim Green

PA Apps Team