

Video Buffer Schematic (Signal Source for THS6002 Amps)

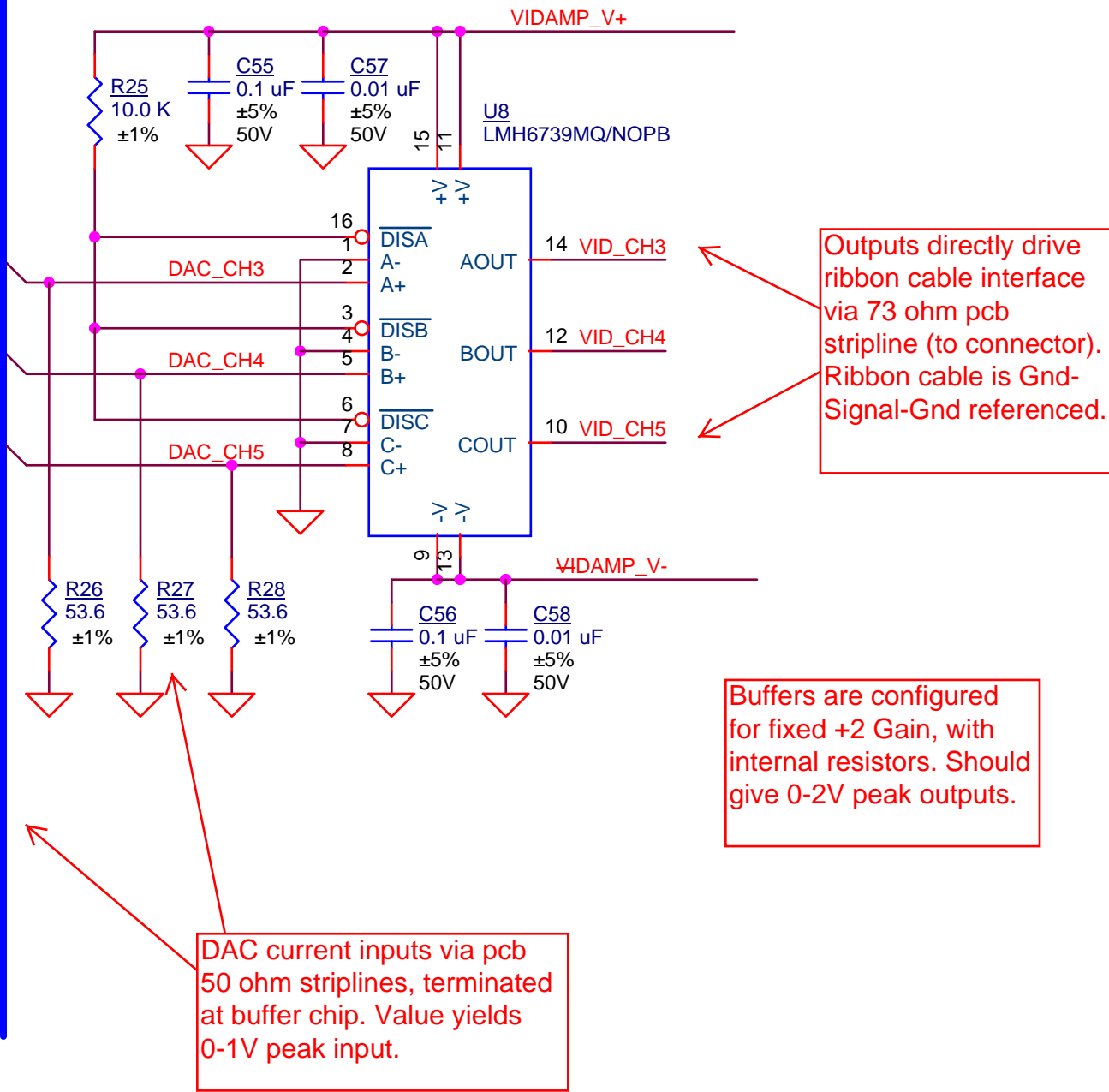

Outputs directly drive ribbon cable interface via 73 ohm pcb stripline (to connector). Ribbon cable is Gnd-Signal-Gnd referenced.

Buffers are configured for fixed +2 Gain, with internal resistors. Should give 0-2V peak outputs.

DAC current inputs via pcb 50 ohm striplines, terminated at buffer chip. Value yields 0-1V peak input.