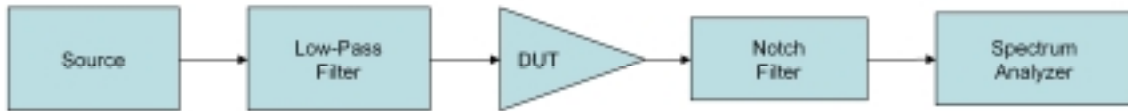


## New Technique Accurately Measures Low-Frequency Distortion To <-130 dBc Levels by Xavier Ramus, Applications Engineer, Texas Instruments Incorporated

Emerging high-resolution converters require a very low distortion last stage interface to maintain their >120 dBc SFDR specifications<sup>(1)</sup>. Typical amplifier distortion measurement techniques usually fail to deliver much more than perhaps 110dBc capability and then only at higher frequencies where the required filters are not setting a limit to the system distortion. A new approach, particularly suited to low frequency distortion measurement, will be described and tested here. This approach eliminates the need for filters while using extremely high-performance, off-the-shelf components to extract the vanishingly low distortion terms of today's high-performance amplifiers. Tested performance at levels previously immeasurable will be shown and the methodology verified.

### Typical Distortion Measurement Approach

This approach is probably the most common method used to measure harmonic distortion. It consists of the following signal chain: Source – Low-Pass Filter – Device Under Test (DUT) – Notch Filter – Spectrum Analyzer (see Fig.1).



**Fig. 1: Typical Distortion Measurement Signal Chain**

The idea is that the distortion originated by the source and the low-pass filter will be much lower than the DUT-generated distortion. In order to measure the DUT distortion within 1 dB the source and the distortion of both filters need to be 15 dB lower than the distortion to be measured. Note that the source distortion is attenuated by the low-pass filter. The notch filter is intended to reduce the fundamental signal to a small level as seen by the spectrum analyzer. One reason for the notch filter is to have the largest dynamic range possible in the spectrum analyzer. The best spectrum analyzers have a dynamic range around 100 dB. Without the notch filter ~100 dBc is the maximum direct measurement achievable. The notch filter allows dramatic reduction of the fundamental and thus allows optimal selection of the most appropriate setting to measure the distortions spurs. This results in measuring a relative distortion level somewhat accurately, due to the source and both filters distortion, down to ~120 dBc but usually only at higher frequencies. The limitation in this case is the noise floor of the spectrum analyzer.

Since we ensure that the spectrum analyzer is not distorting, using the notch filter, the components of the resulting measurement at the spectrum analyzer include the linear addition of the source and both filters' distortion with the DUT distortion. This can be expressed as:

$$HD_{X\_Measured(V_{RMS})} = HD_{X\_DUT(V_{RMS})} + HD_{X\_Filter\&Source(V_{RMS})} \quad \text{Eq 1}$$

with,

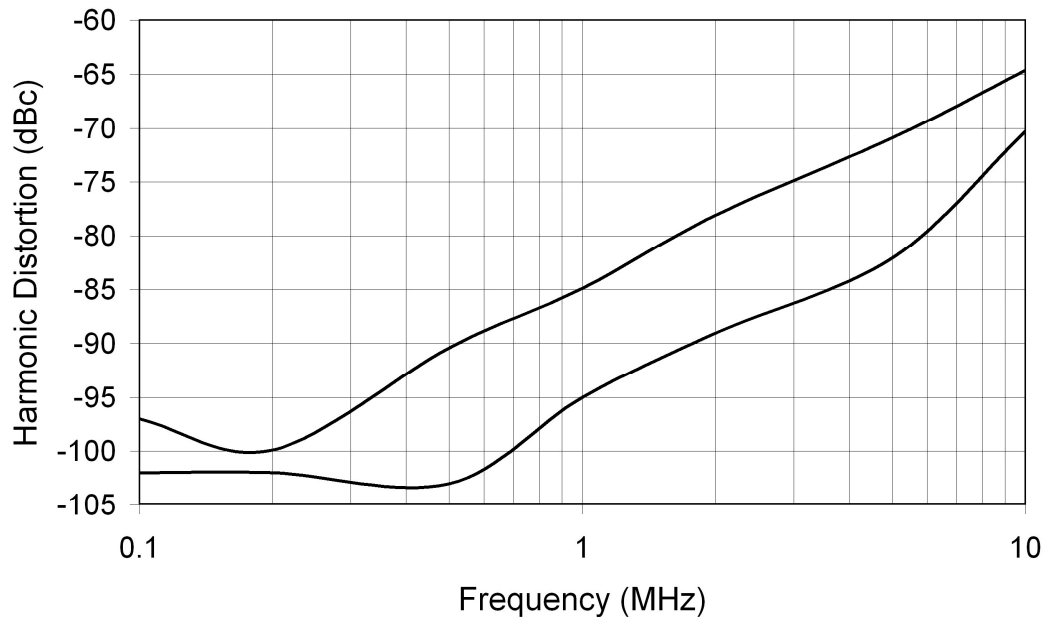
$$HD_{X(V_{RMS})} = 10^{\frac{HD_{(dBc)}}{20}} \quad \text{Eq. 2}$$

and  $HD_x$  is the  $x^{\text{th}}$  harmonic distortion.

In summary, this approach has the advantage of having a fairly straightforward setup, is typically good for frequencies above 1 MHz in that the low-pass and notch filters do not create distortion. Lower frequency filters tend to be limited in their distortion performance due to the larger inductor values requiring a ferrite core which introduce their own distortion terms.

### Typical Results

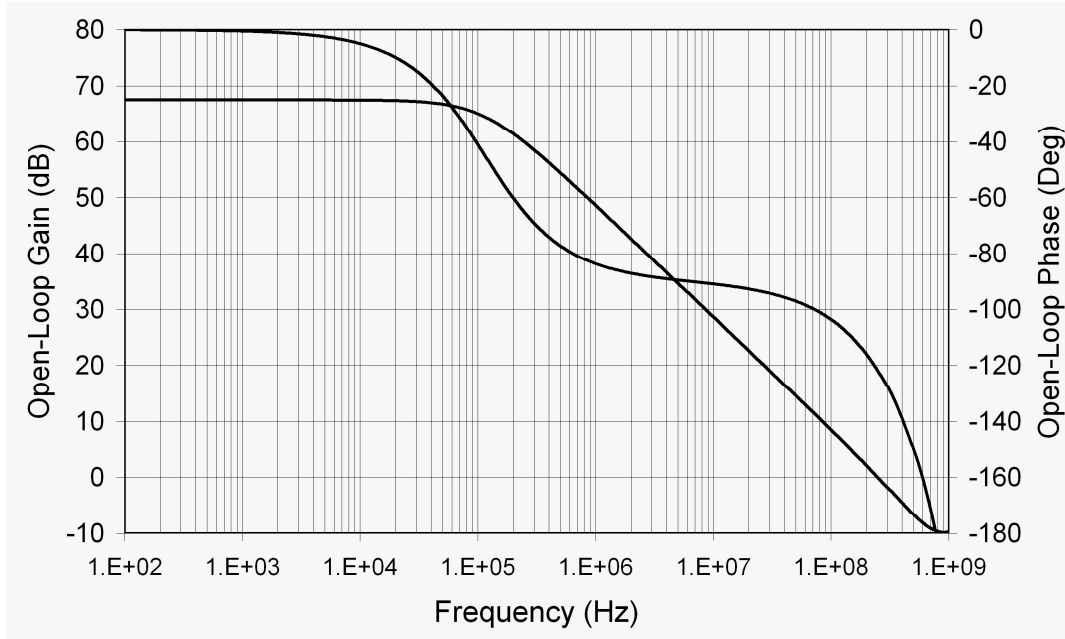
The OPA820, a unity-gain stable, low-noise, voltage-feedback op amp is used here for illustration purposes. The OPA820 gain of +2 V/V *Harmonic Distortion Performance versus Frequency* plot has been extracted from the data sheet and is shown in Fig. 2. This data was generated using the test setup of Fig. 1.



**Fig. 2: OPA820 G = +2 V/V Harmonic Distortion (HD) Vs Frequency**

Notice that from 100 kHz to 600 kHz, the 3rd HD (lower) seems to have reached a floor of ~-105 dBc. For the 2nd HD (upper) the floor appears to be near 200 kHz at ~-100dBc.

Looking at the *Open-Loop Gain and Phase* plot of the same device (Fig. 3) you would expect the minimum distortion level to be reached below 100 kHz.

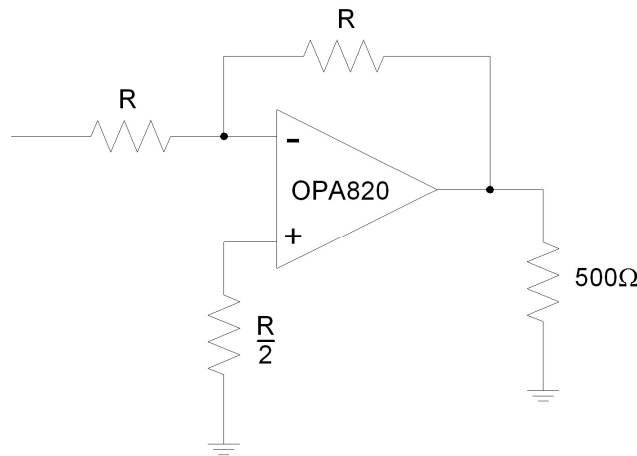


**Fig. 3: OPA820 Open-Loop Gain And Phase Plot**

If we say that this measurement approach is limited to  $\sim 100$  dBc, what performance should we expect from the OPA820? We will analyze that in detail.

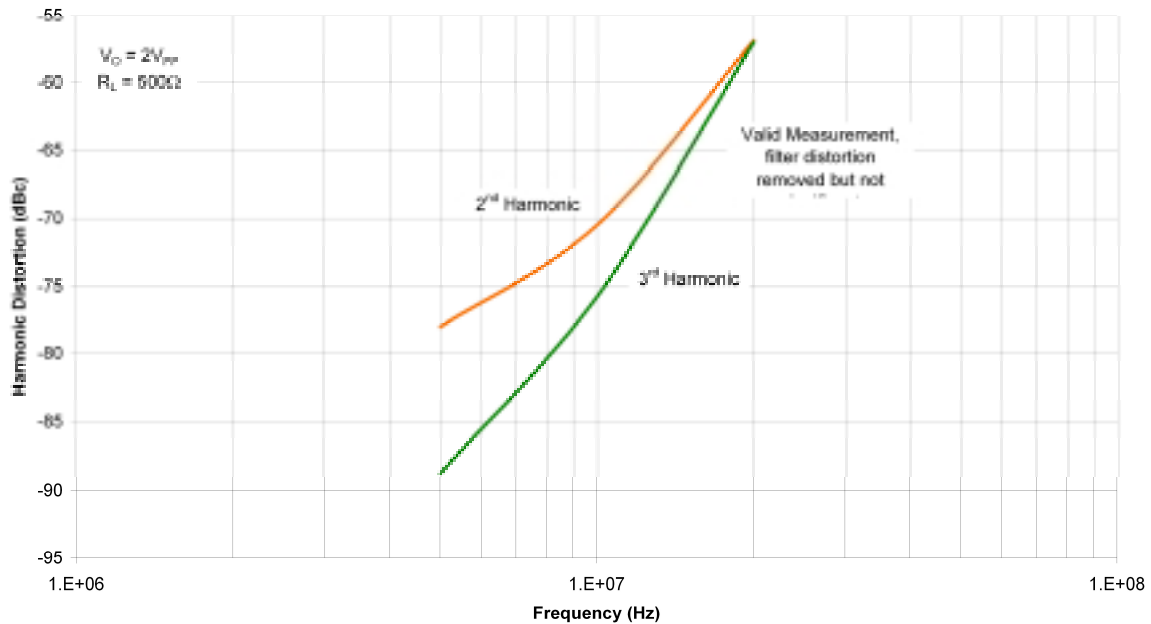
### Low-Gain Initial Estimate Of Low-Frequency HD

One goal for this technique is to determine the harmonic distortion for amplifiers in ADC driver applications. We will, therefore, set the load of the amplifier to  $500 \Omega$  for the tests, with the amplifier in an inverting configuration with a gain of  $-1$  V/V (see Fig. 4).



**Fig. 4: Circuit Configuration For The Low-Frequency Initial Estimate**

For the OPA820, R is set to 402  $\Omega$ . Measuring with the method described above and calibrating the source and filter distortion out of the measurement for a gain of -1 V/V, a 2 Vpp signal and a 500  $\Omega$  load gives us a baseline (see Fig. 5). Note that we kept only the values that were as far away as possible from the floor (Fig. 2, again). By doing this, we are limited to the higher frequency measurements.

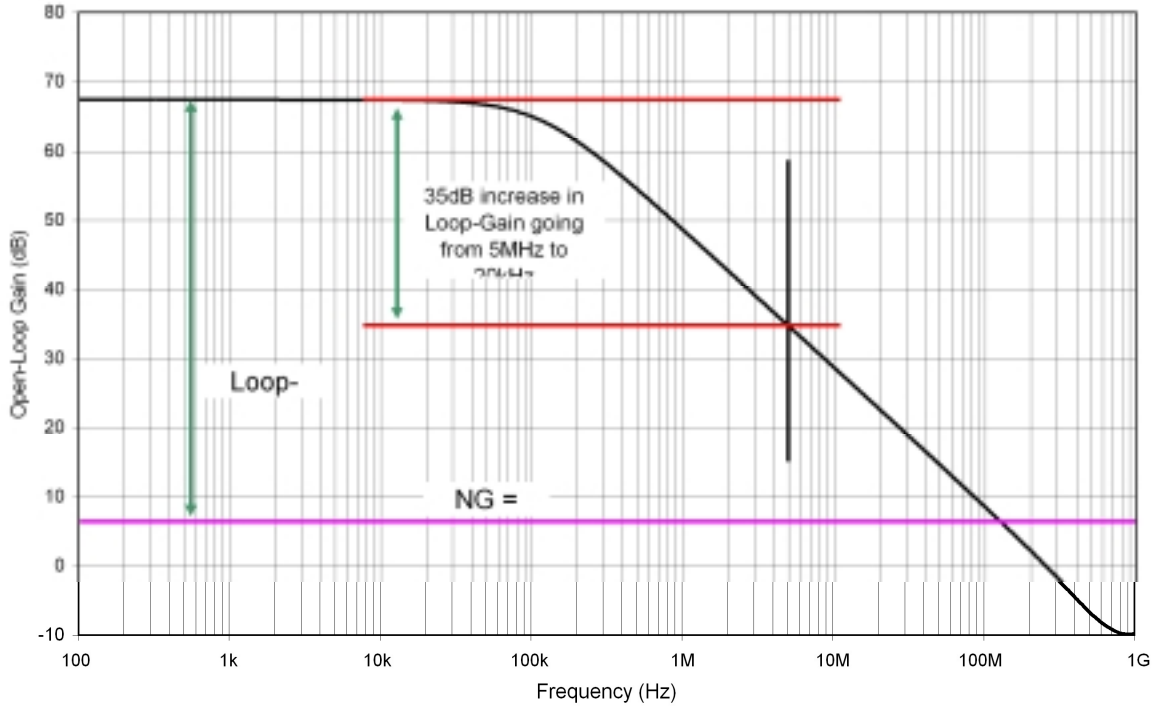


**Fig. 5: High-Frequency Measurement Used To Establish The Baseline**

Since we are limited in the measurement to higher frequencies a second element required to estimate a low-frequency baseline is the open-loop gain plot from the data sheet (Fig. 3).

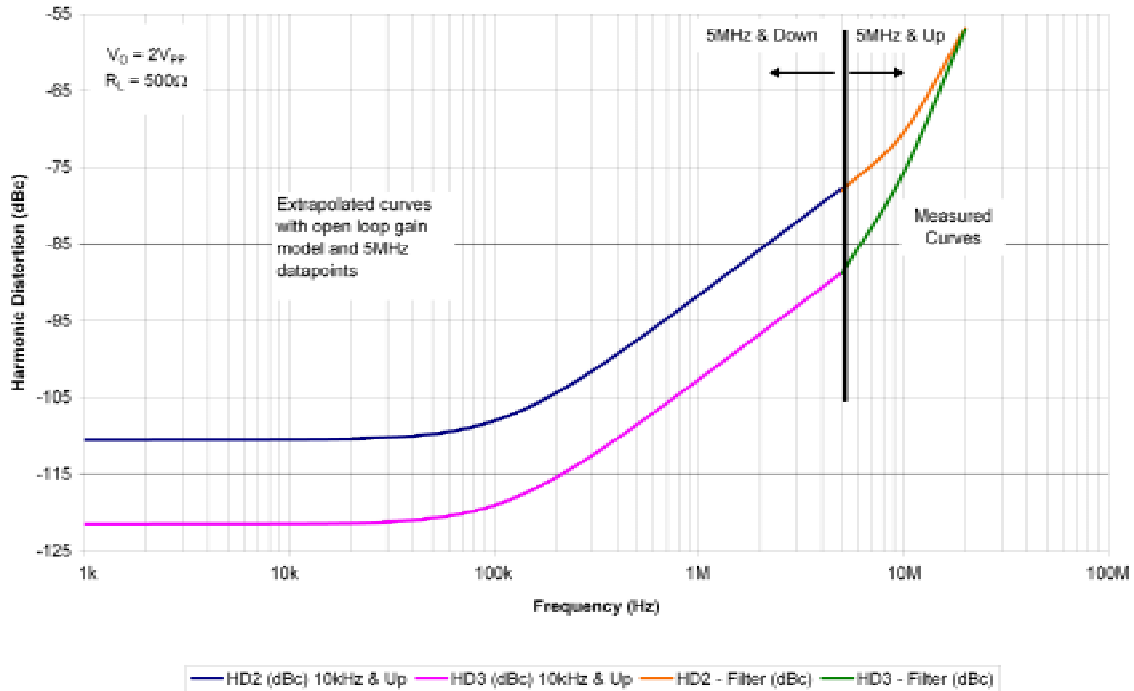
Calculating the loop-gain as the difference between the noise gain ( $NG$ ,  $NG = 1 + \frac{R_F}{R_G}$ )

of the amplifier and the open-loop gain, then calculating the loop-gain difference between 5 MHz and 20 kHz, and applying that loop-gain correction to the 5 MHz harmonic distortion point from Fig. 5 (HD2 = -77 dBc, HD3 = -88 dBc) will give us the expected value at 20 kHz (see Fig. 6).



**Fig. 6: Possible Loop-Gain Correction Going From 5 MHz to 20 kHz**

Below 20 kHz, no further loop-gain correction can be expected and the minimum distortion should have been achieved. The harmonic distortion can then be re-plotted to get the low-frequency harmonic distortion baseline that should be achievable by the OPA820, a 35 dB improvement for the OPA820 from 5 MHz to 20 kHz.



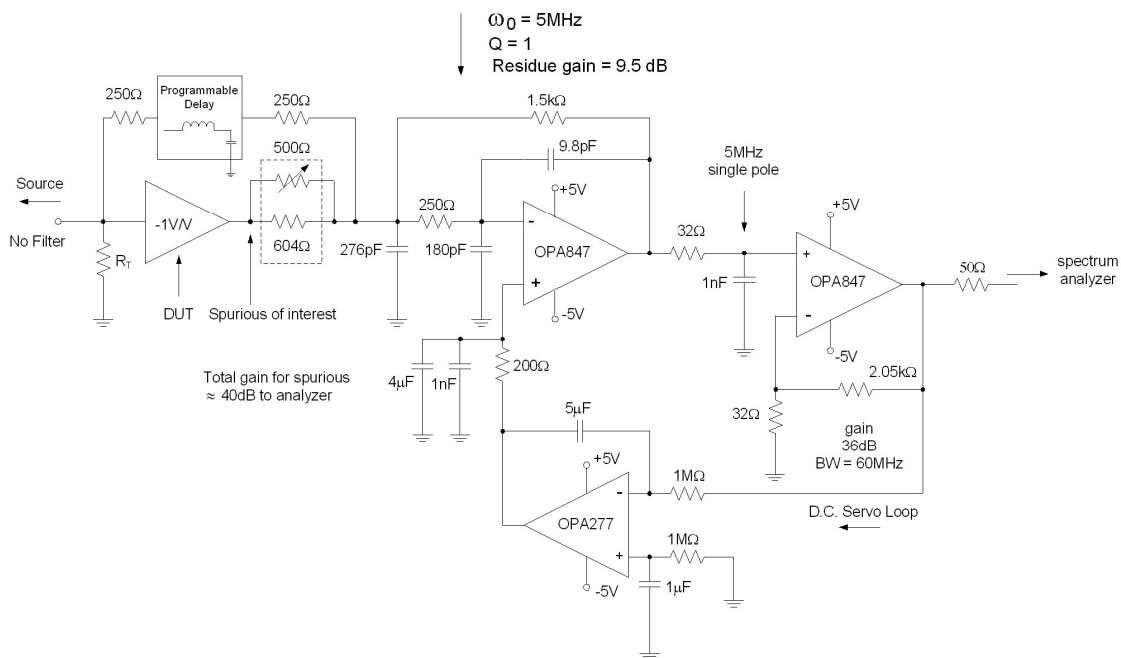
**Fig. 7: Low-Gain, Low-Frequency Harmonic Distortion Baseline For The OPA820**

The low-frequency harmonic distortion baseline for the OPA820 is shown in Fig. 7. For frequencies above 5 MHz, the measured data has been plotted and for frequencies below 5 MHz, the loop-gain correction model has been applied to the 5 MHz number. The harmonic distortion for frequencies below 20 kHz are reaching the minimum distortion that can be expected for this amplifier.

Now that we have established a baseline, we can turn our attention toward measuring the -111 dBc level for HD2 and the -122 dBc level for HD3.

### New 'Source HD-Cancellation' Approach

The technique described here is intended for an inverting amplifier configuration. This method makes use of the phase inversion that the DUT provides to feed both the source signal and the DUT output to the two inputs of an inverting summing amplifier. This summing amplifier provides the cancellation of the fundamental as well as the source harmonics. The full test schematic is shown in Fig. 8.

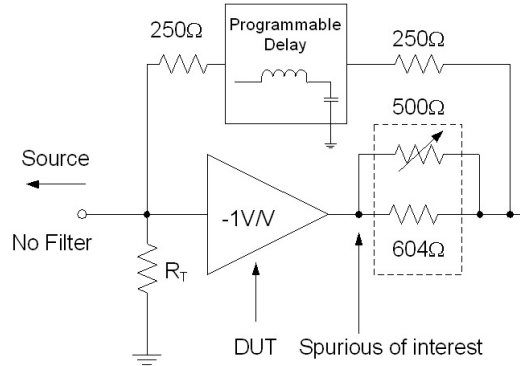


**Fig. 8: Source Cancellation Technique For Inverting Gain Distortion Measurement Circuit**

The summing operation at the OPA847 inverting input will have two sources of error that will require some kind of correction to optimize the measurement range. A gain error is present, which is mostly due to the mismatch between the gain and feedback resistors used to set the DUT gain and the mismatch between summing resistors. These DUT feedback and gain resistors are not shown in Fig. 8 for simplification purposes. The other error is the propagation delay of the signal through the DUT.

## DUT Error Compensation

To optimize the cancellation of the fundamental and the source's distortion through the summing amplifier requires adjusting one of the summing resistors. This is done here (Fig. 9), by adding a potentiometer in parallel with the summing resistor in the DUT path.



**Fig. 9: DUT Error Compensation**

Choosing the summing resistor in the DUT path instead of the summing resistor connected to the source allows for better source impedance matching. Note that the summing resistance in the DUT path is also the load of the DUT. This first adjustment takes care of the dc gain matching. The ac matching is provided by a programmable delay incorporated in the summing resistance going from the source to the summing junction. This delay consists of inductors and capacitors chosen to provide the appropriate delay. An LC-delay line as used here can be calculated from the following equations:

$$t_D = \sqrt{L \cdot C}$$

$$Z_O = \sqrt{\frac{L}{C}}$$

Eq 3

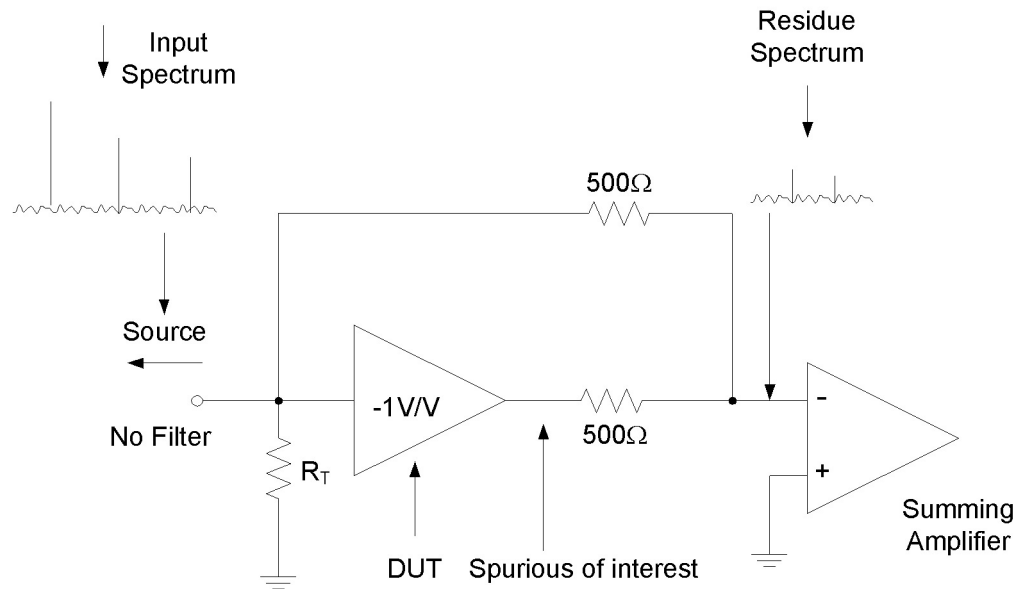
with,  $t_D$  the total delay (ns),  $Z_O$  the impedance ( $\Omega$ ),  $L$  the total line inductance ( $\mu\text{H}$ ) and  $C$  the total line capacitance (pF).

Now that the DUT has been compensated for both gain mismatch and propagation delay, we'll describe this circuit's input stage.

## Input Stage Description

The summing amplifier has one of its input resistances connected to the source seeing the same signal as the DUT input and the other summing resistance connected to the DUT output seeing a signal  $180^\circ$  out of phase from the source. Since both signals are out-of-phase, the summing amplifier rejects all signals coming from the source. This applies not only to the fundamental but also to the entire input spectrum. This, ideally, leaves only the DUT distortion as the residue spectrum. This is represented in Fig. 10. Since perfect cancellation is impossible to achieve, the monitoring of the input spectrum as well as the

cancellation through the summing amplifier is required to ensure the measurement validity. In practice, good cancellation is achieved to 1 MHz for the fundamental and 3 MHz for the 3rd harmonic. One requirement for good cancellation is testing a DUT with a bandwidth much higher than the test frequencies of interests.



**Fig. 10: Input Stage Circuit**

### Summing Amplifier Description

Since the summing amplifier provides the DUT load ground reference, the goal is to get the best virtual “in-band” ground possible. This was implemented with the highest gain bandwidth product operational amplifier available. Also, since this stage is at the beginning of a medium-gain signal chain and that noise is a concern in order to raise as little as possible the noise floor of the spectrum analyzer, the OPA847 was chosen (3.6 GHz gain-bandwidth product and 0.85 nV/ $\sqrt{\text{Hz}}$  input referred voltage noise). A 3rd order Butterworth active filter was implemented as well using the MFB feedback. This MFB<sup>(2)</sup> implementation with a non-unity gain stable operational amplifier required a noise gain shaping capacitor to hold it stable.

The filter characteristics are the following:

- Cut-off frequency:  $\omega_0 = 5 \text{ MHz}$
- Quality coefficient:  $Q = 1$
- Gain for the residue:  $G_{\text{Residue}} = 9.54 \text{ dB}$

The frequency response for the Fig. 11 schematic is shown in Fig. 12. Note, that in order to realize the filter design for this circuit, the source impedance for both inputs of the summing junction was combined as a 250  $\Omega$  resistor. The residue signal has a gain of -3 V/V (9.5 dB) to the output of this stage.



3<sup>rd</sup> order, gain of -6V/V  
5MHz Butterworth

$\omega_0 = 5\text{MHz}$   
 $Q = 1$   
Residue gain = 9.5 dB

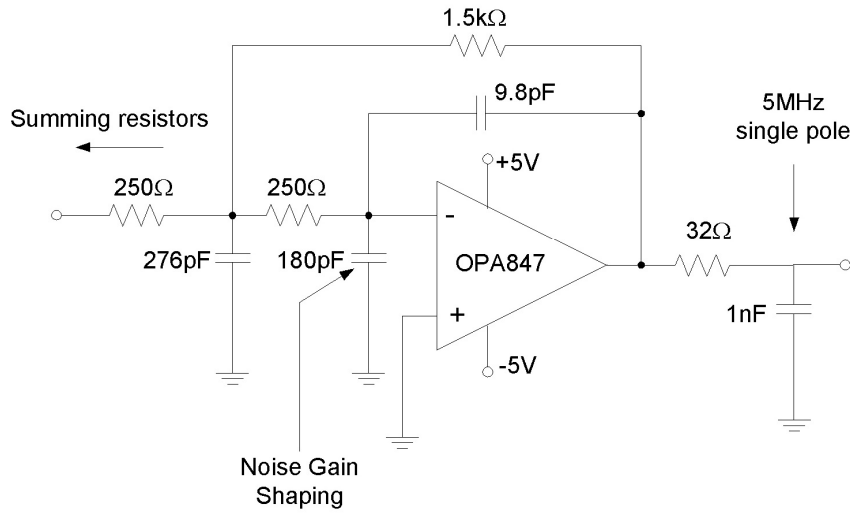


Figure 11: Summing Amplifier Schematic

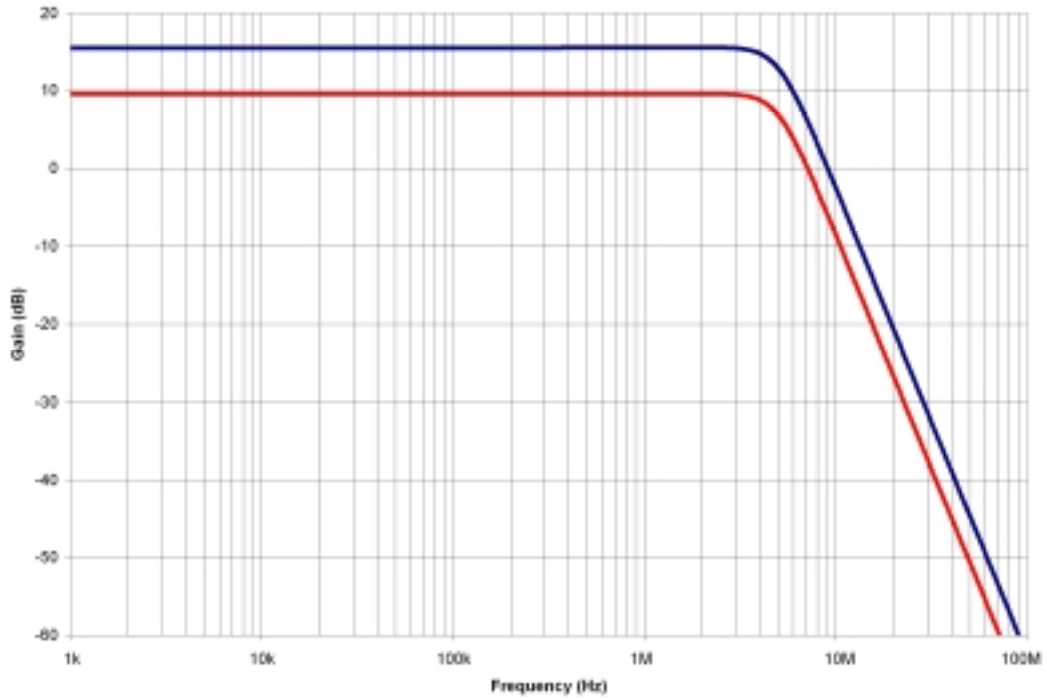
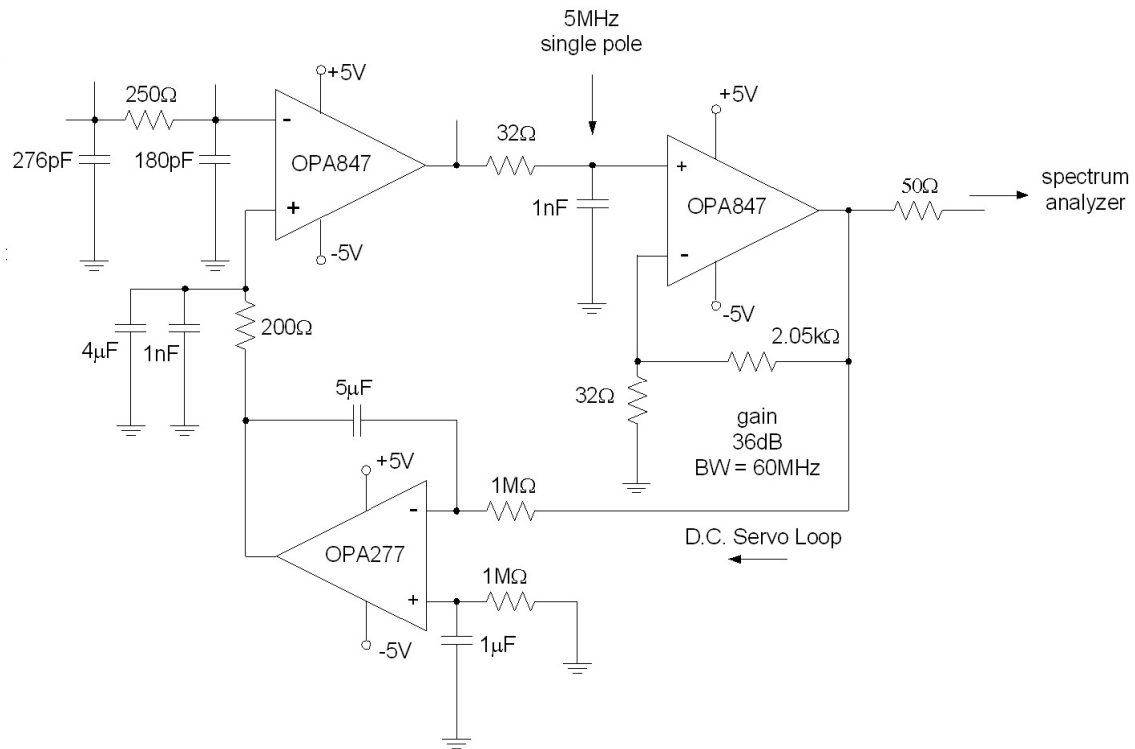


Fig. 12: Filter & Residue Frequency Response

## Other Circuit Elements

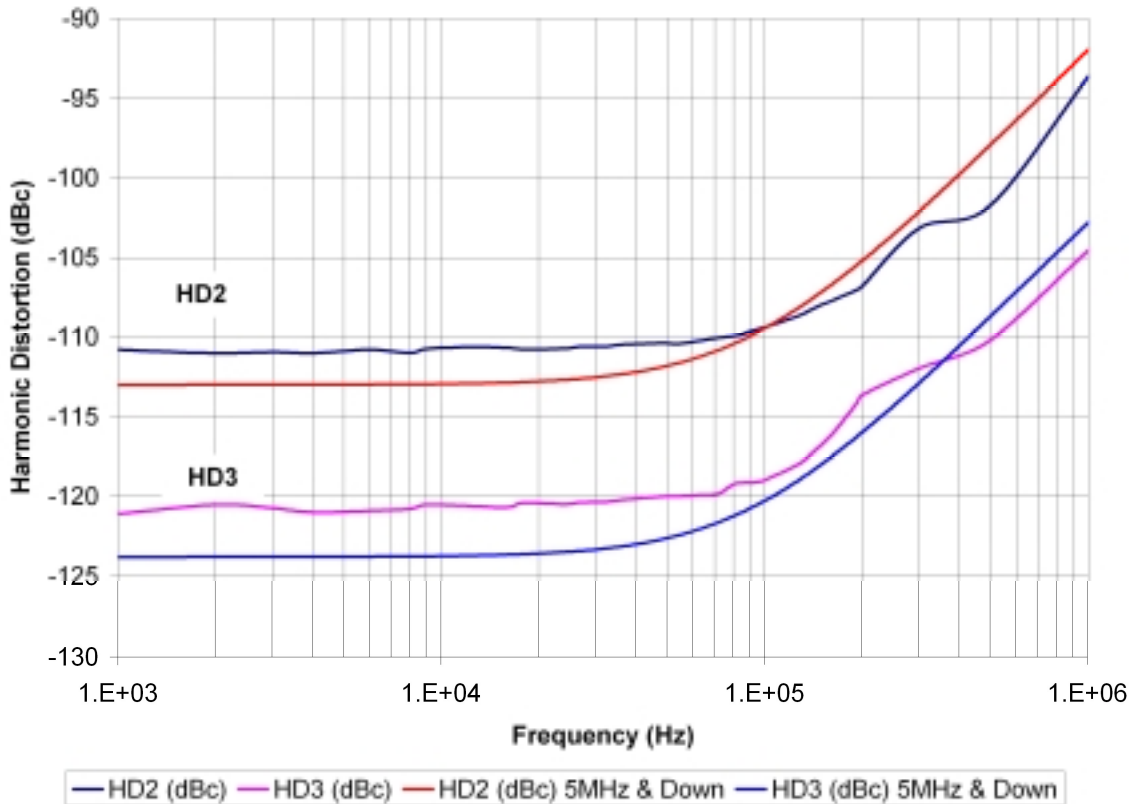
The two final elements in this test circuit are a low-noise post amplifier, again an OPA847 (at a gain of 36 dB) and a dc servo loop to zero out the dc offset in this high-gain residue amplifier channel. This allows the output to be dc-coupled to the spectrum analyzer but this will set a lower frequency limit to the measurement channel. That lower limit will be set by the integrator pole around the OPA277 stage and the gain in the signal chain. In this implementation, the integrator pole is set to 16 Hz giving just 0.01 s time constant. This loop then requires less than 0.1 s to settle into a final value while also maintaining excellent flatness at the minimum intended measurement frequency of 1 kHz.



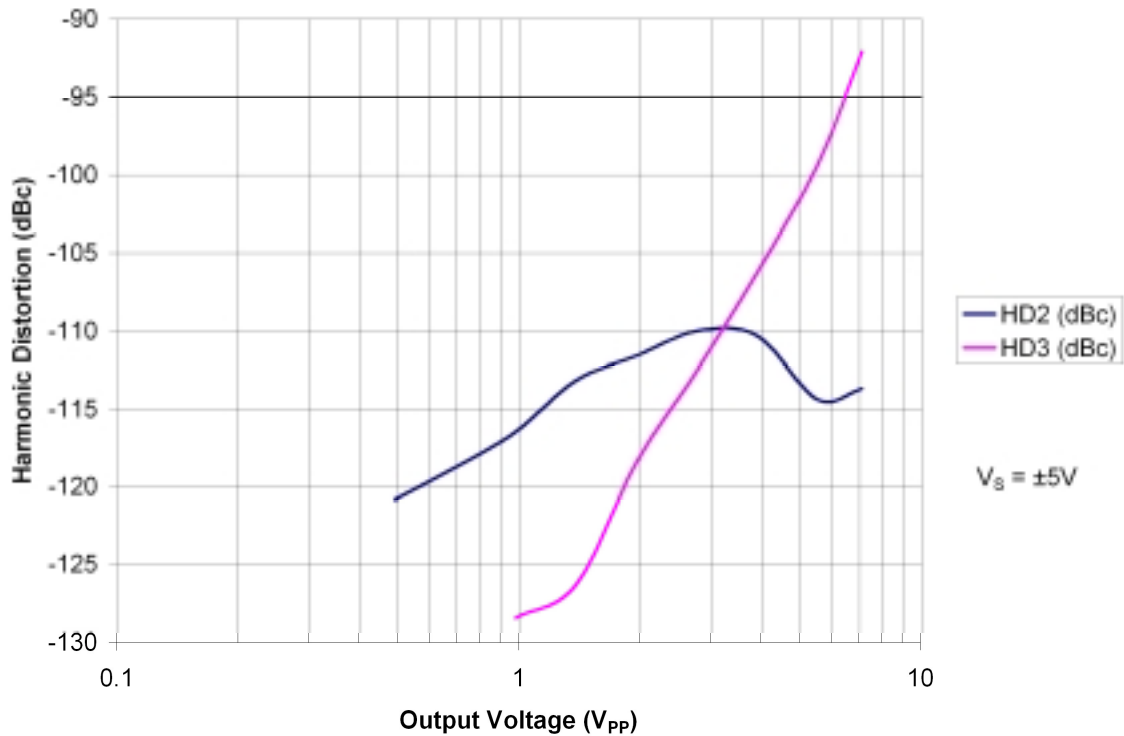
**Fig. 13: Residue Gain Amplifier & Dc Servo Loop**

## Measured Results

The OPA820 measured results vs. extrapolated results (Fig. 7) are shown in Fig. 14. The measured results appear in dark blue for HD2 and pink for HD3. Extrapolated results appear in red for HD2 and light blue for HD3 and are the smoother curves. The measured data matches the extrapolated curves to within a couple of dB. To confirm that the OPA820 performance was actually measured and not some other elements, the distortion should vary with the output swing of the OPA820. This is shown in Fig. 15.



**Fig. 14: OPA820 Measured & Extrapolated HD2 & HD3,  
 $V_O = 2\text{ Vpp}$ ,  $R_L = 500\ \Omega$ ,  $V_S = \pm 5\text{ V}$**



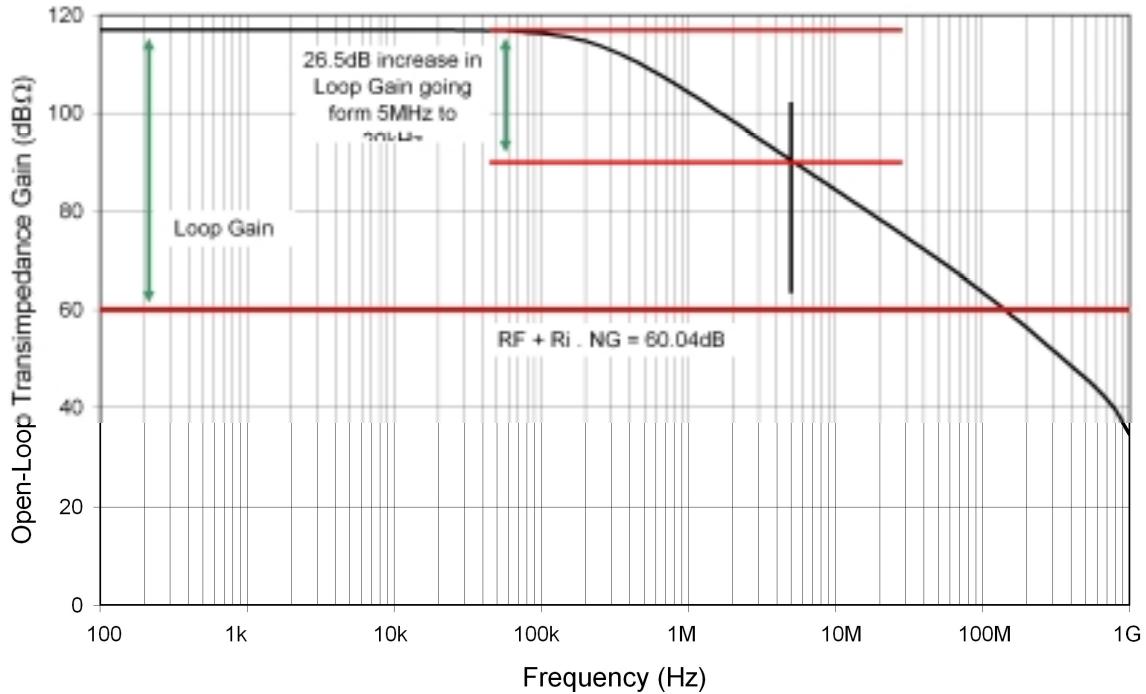
**Fig. 15: OPA820 Harmonic Distortion Vs. Output Voltage,  
 $V_O = 2 V_{pp}$ ,  $R_L = 500 \Omega$ ,  $V_S = \pm 5 V$**

In Fig. 15, the data up to 3 V<sub>pp</sub>, shows the output swing of the second harmonic increasing by 6 dB every time the output amplitude is doubled as would be expected. The third harmonic increases 12 dB every time the output swing is doubled as would also be expected. This confirms that the measurement is valid and that the method measures to at least -130 dB as seen in Fig. 15 for HD3 at 1 V<sub>pp</sub>.

Now that the method has been proven to work with a voltage-feedback amplifier, we can start looking at current feedback amplifiers.

## Loop Gain Correction Model For Current-Feedback Amplifiers

Current-Feedback amplifiers require a different model for loop gain correction than voltage-feedback amplifiers. For current-feedback amplifiers, the loop-gain is the difference between the open-loop transimpedance gain and the sum of the feedback resistor with the product of the inverting input resistance and the noise gain, or  $LG = Z_{OL} - (R_F + r_i \cdot NG)$ . This is shown in Fig. 16.



**Fig. 16: Loop Gain Correction Model For A Current-Feedback Amplifier**

This figure shows that for the OPA684, a low-power, current-feedback operational amplifier with disable, the distortion could be improved by 26.5 dB by going from 5 MHz to 20 kHz. This represents a lesser possible improvement than for the voltage-feedback amplifier shown previously. However, one advantage of a current-feedback amplifier vs. voltage-feedback amplifier can be seen at larger gain.

Let's say that for a voltage-feedback amplifier, we want a gain of -10 V/V instead of -1 V/V. The loop gain degradation because of that extra gain is ~14.8 dB. For a current-feedback amplifier like the OPA684, the loop gain degradation going from -1 V/V to -10 V/V gain is ~0.2 dB. Maintaining the distortion performance, somewhat independently of the gain, is a characteristic of current-feedback amplifiers.

Results for the OPA684 at a gain of -10 V/V for a 1 kΩ load are shown in Figs. 17 and 18.

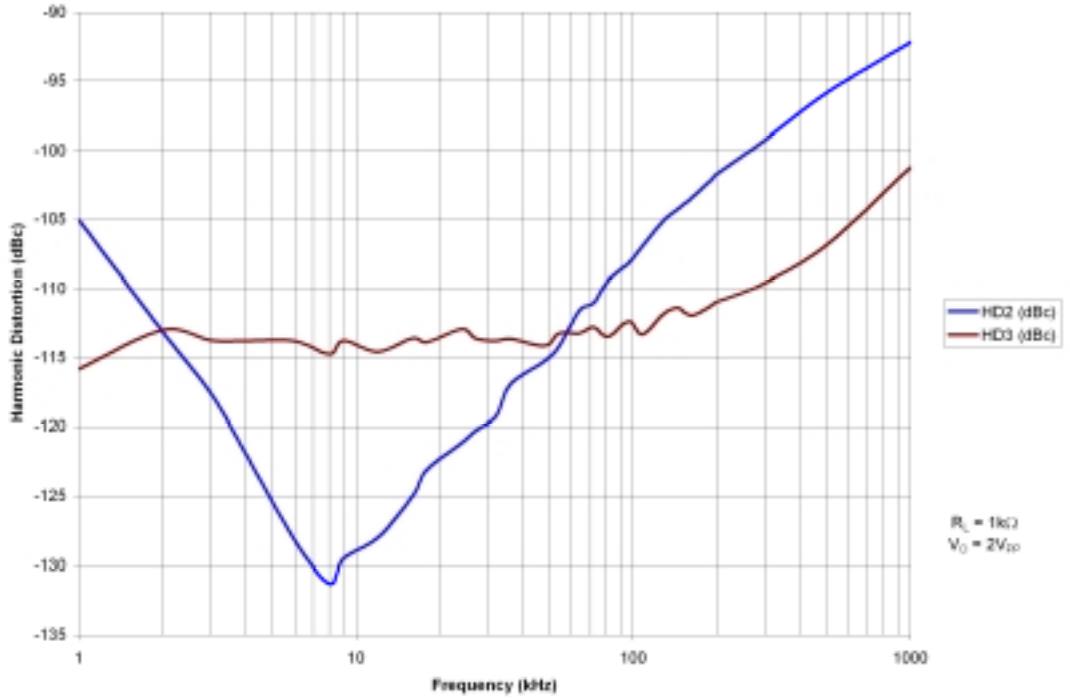


Fig. 17: OPA684,  $G = -10 \text{ V/V}$ ,  $V_O = 2 \text{ Vpp}$ ,  $R_L = 1 \text{ k}\Omega$ ,  $V_S = \pm 5 \text{ V}$

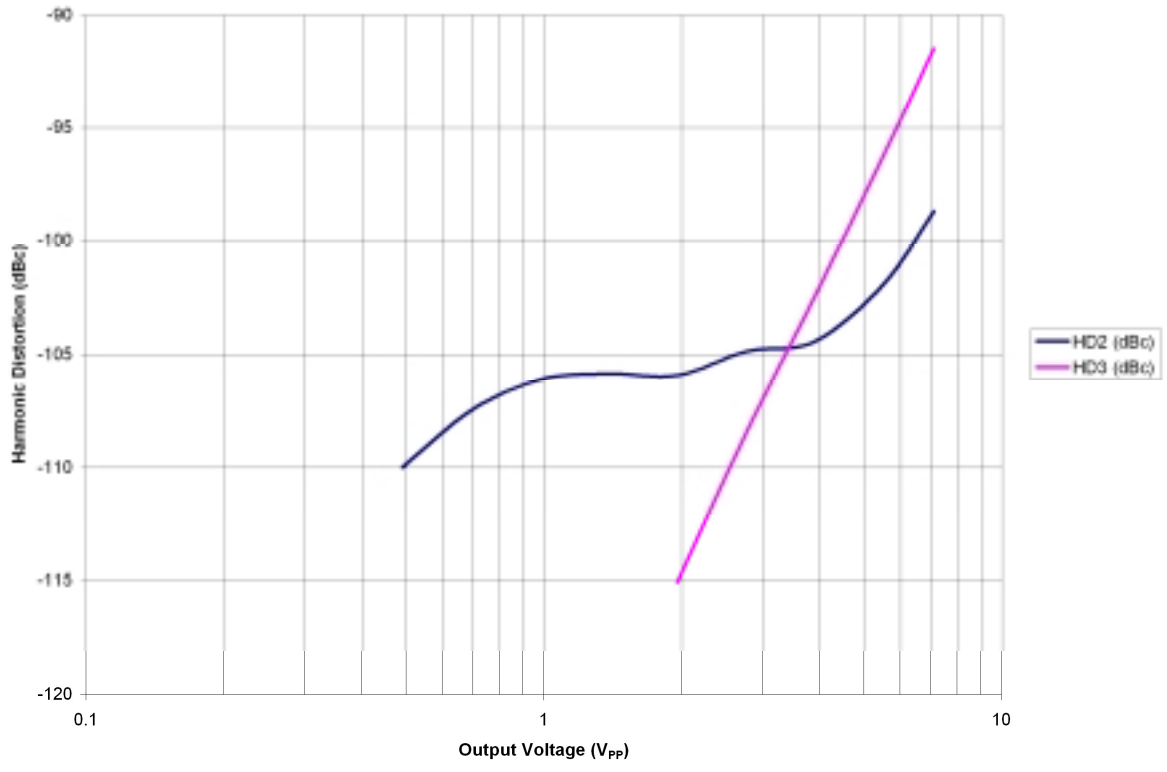
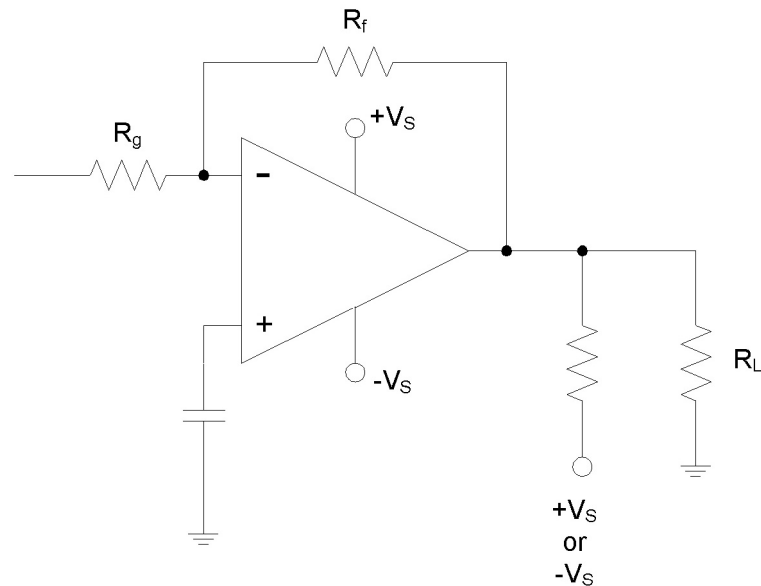


Fig. 18: OPA684, 1 kHz HD Vs.  $V_O$ ,  $R_L = 1 \text{ k}\Omega$

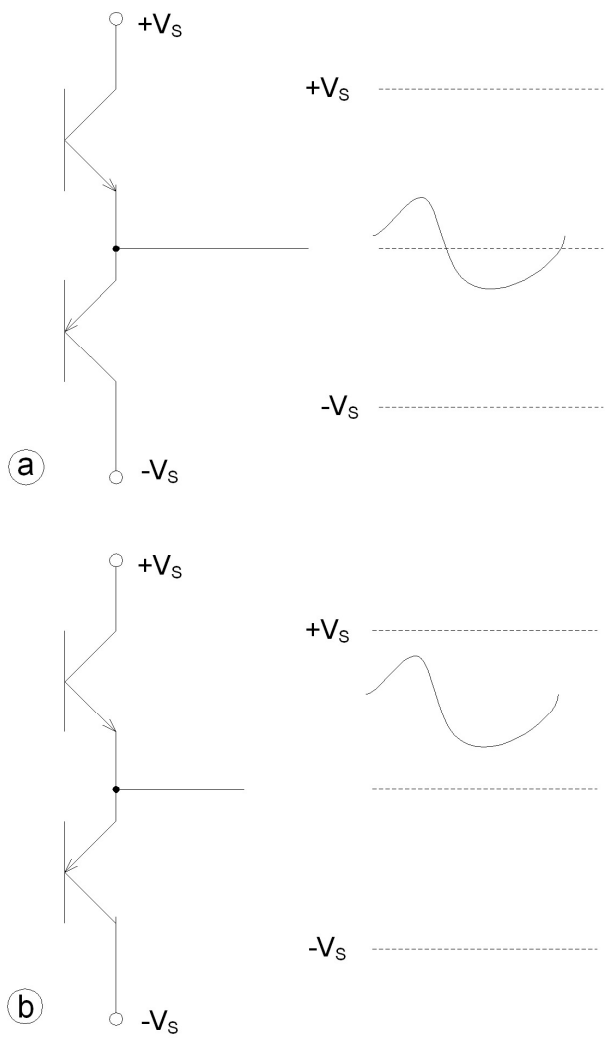
## Improving Performance By Adding Class-A Current

Adding Class-A current at the output of an op amp is achieved by adding a pull-up or pull-down resistor to one of the supply voltages of the operational amplifier. A pull-up resistor to the positive supply will force the output of the amplifier to sink current whereas a pull-down resistor to the negative supply will force the amplifier to source current. This is depicted in Fig. 19. Note that the load seen by the amplifier is now the parallel combination of the load resistance with the feedback resistance and the pull-up or pull down resistance.



**Fig 19: Adding Class-A Current To An Op Amplifier**

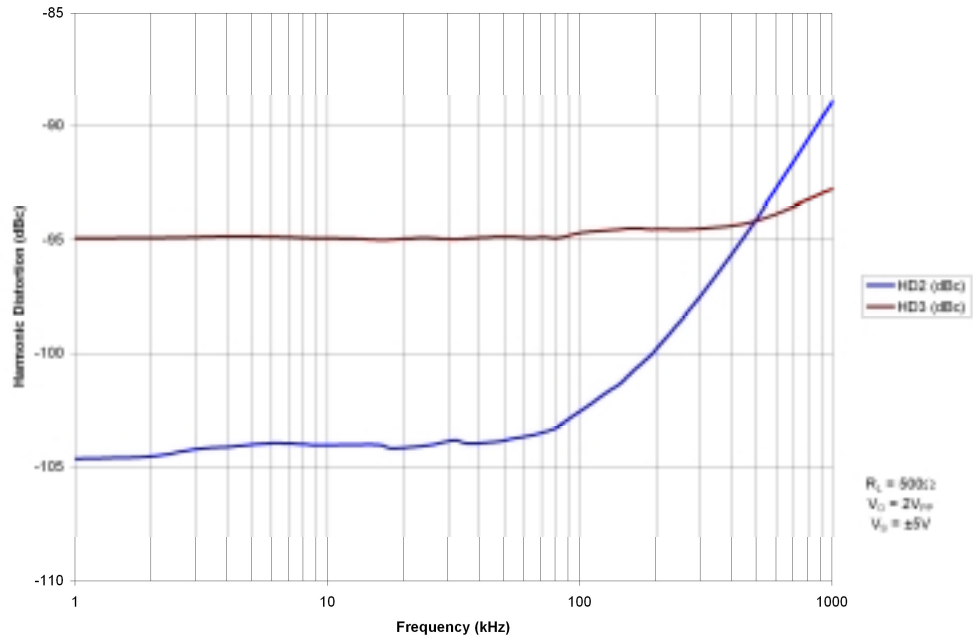
The amount of current that you add depends on the total output swing. The idea here is to have the entire output signal swing operate on one of the output transistors and, therefore, avoid the crossover distortion. This is shown in Fig. 20. This method is intended to improve the 3rd harmonic distortion but may affect the 2nd adversely.



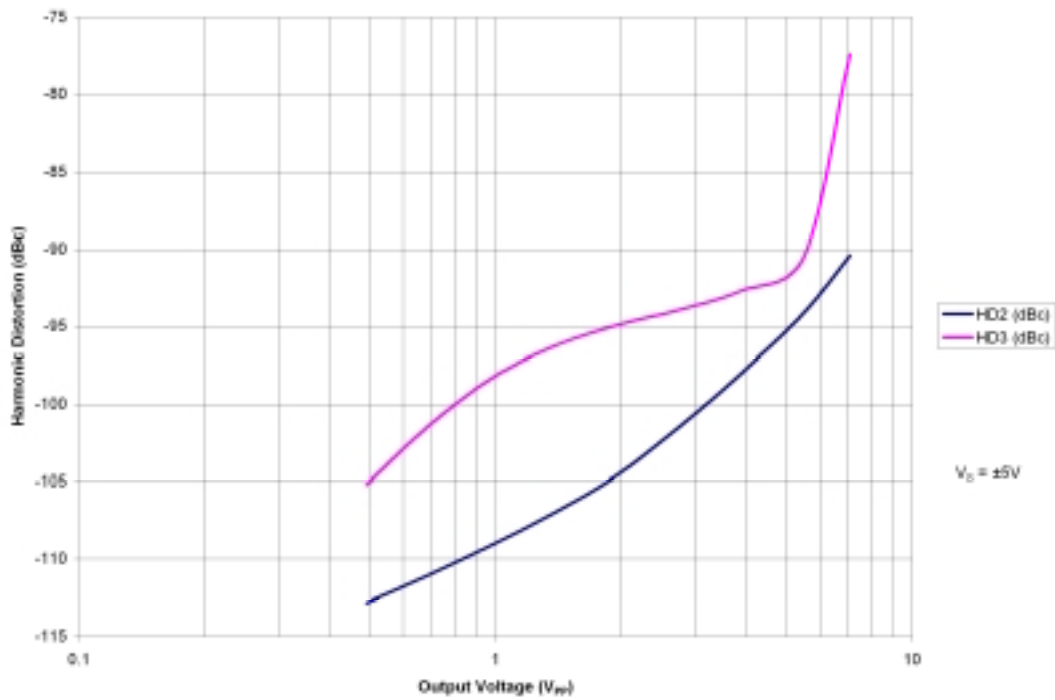
**Fig. 20: a) Normal Output Operation, b) Class-A Current Affecting Output Swing**



Here we are going to use the OPA690 as a test vehicle. The OPA690 was chosen as it has low-frequency performance that could use improvement on HD3 while HD2 is really good. It also has a large output drive capability. Initial distortion performances for the OPA690 are given in Figs. 21 and 22.

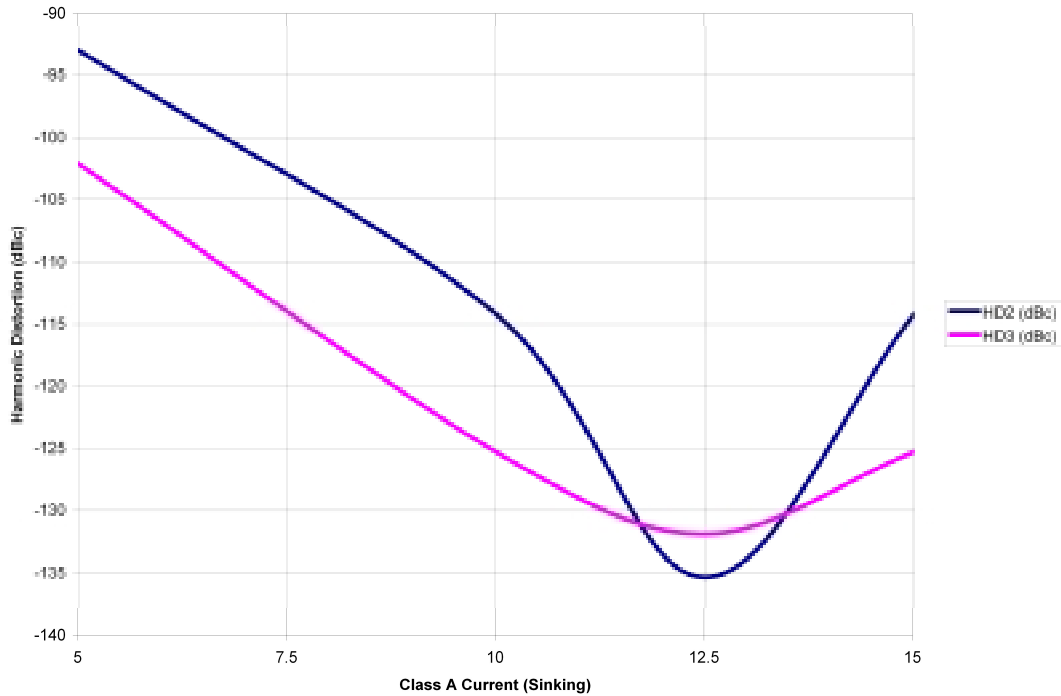


**Fig. 21: OPA690 HD Vs. Frequency,  $R_L = 500 \Omega$ ,  $V_O = 2 V_{pp}$ ,  $V_S = \pm 5 V$**



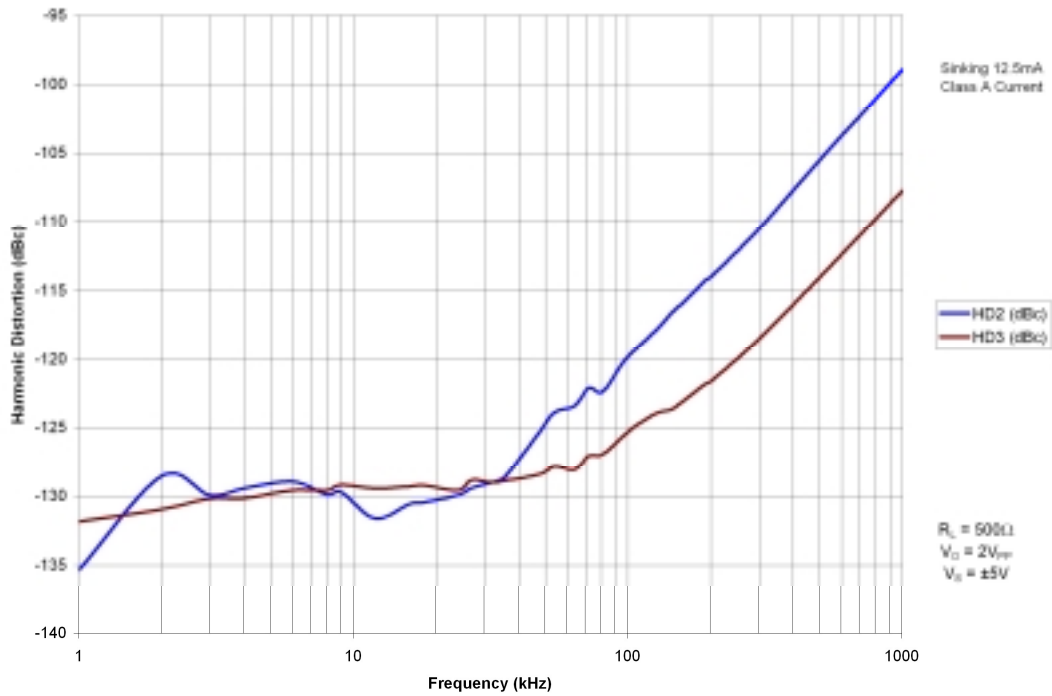
**Fig. 22: OPA690 1 kHz HD Vs.  $V_O$ ,  $R_L = 500 \Omega$ ,  $V_S = \pm 5 V$**

Choosing to sink current at the output of the OPA690 and measuring both HD2 and HD3 at 1 kHz into a 500  $\Omega$  load on top of the pull-up resistor, we see in Fig. 23 that there is some improvement at first, an optimum and then the performance starts to degrade as the total load seen by the amplifier becomes more dominant.

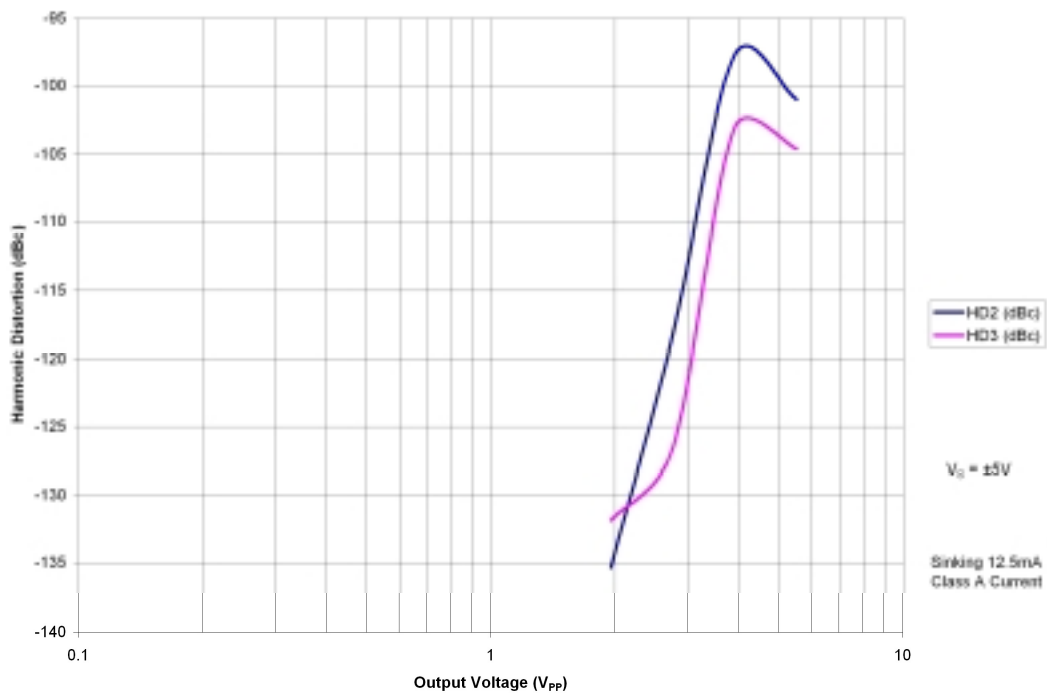


**Fig. 23: 1 kHz HD2 And HD3 Vs. Class-A Current For 2 Vpp signal**

Now that we have found the optimum operating point for the OPA690, we can retake the data over frequency and output swing. See Figs. 24 and 25.



**Fig. 24: OPA690 Harmonic Distortion Operating At Optimal Class-A Current**



**Fig. 25: 1 kHz OPA690 Harmonic Distortion Vs.  $V_O$  At Optimal Class-A Current**

Note that the rule of 6 dB degradation for HD2 and 12 dB for HD3 as the output swing doubles is no longer valid.

## Fully-Differential Amplifier

The methodology developed in the previous discussion for op amps can be extended further for a fully-differential amplifier. The full schematic, shown in Fig. 26a, makes use of two of the schematics shown in Fig. 8 with a differential-to-single-ended conversion realized by an INA217. Also note that the OPA843 is used as a summing amplifier in place of the OPA847. The board, fully populated in the test environment, is shown in Fig. 26b.

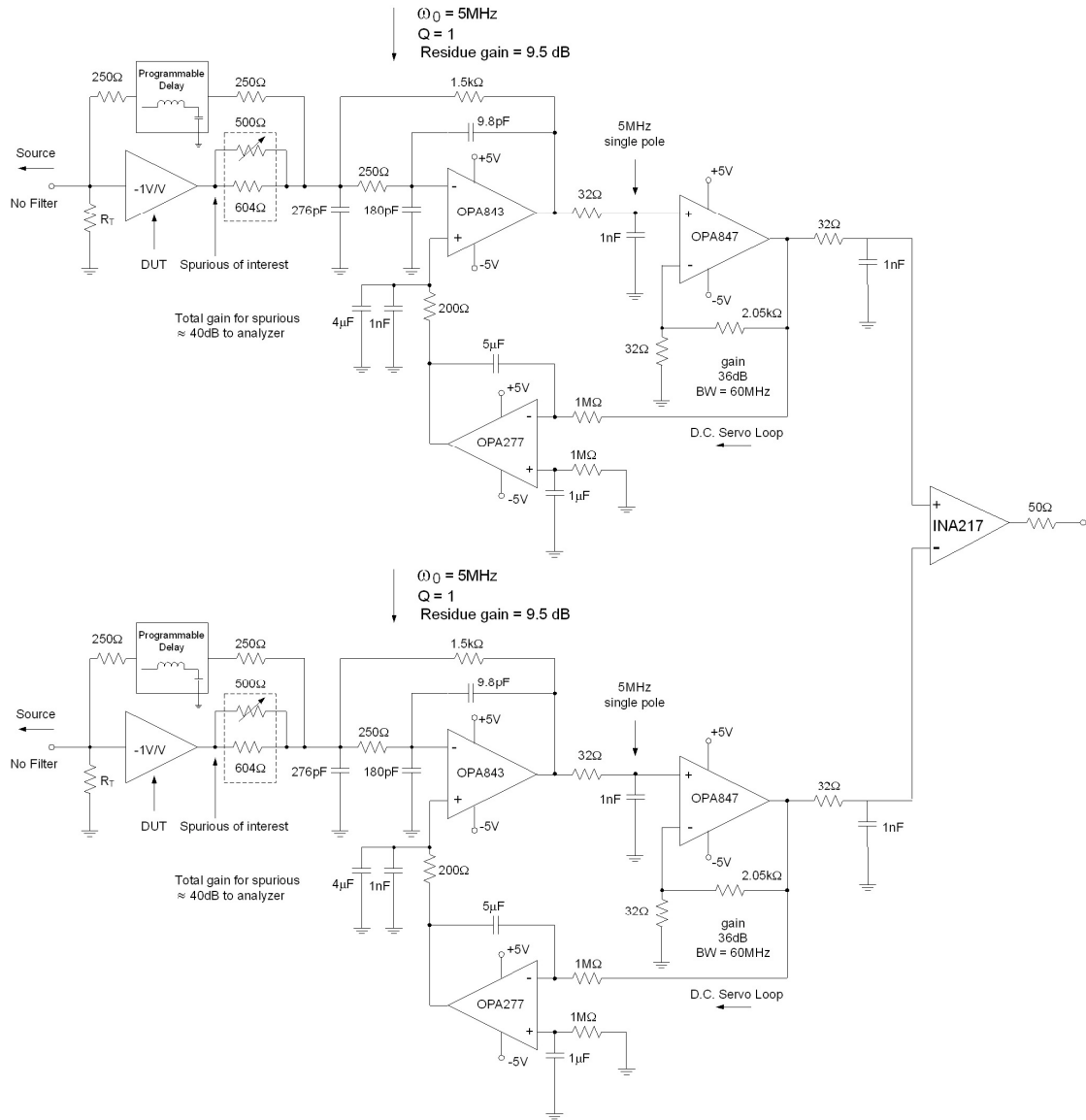
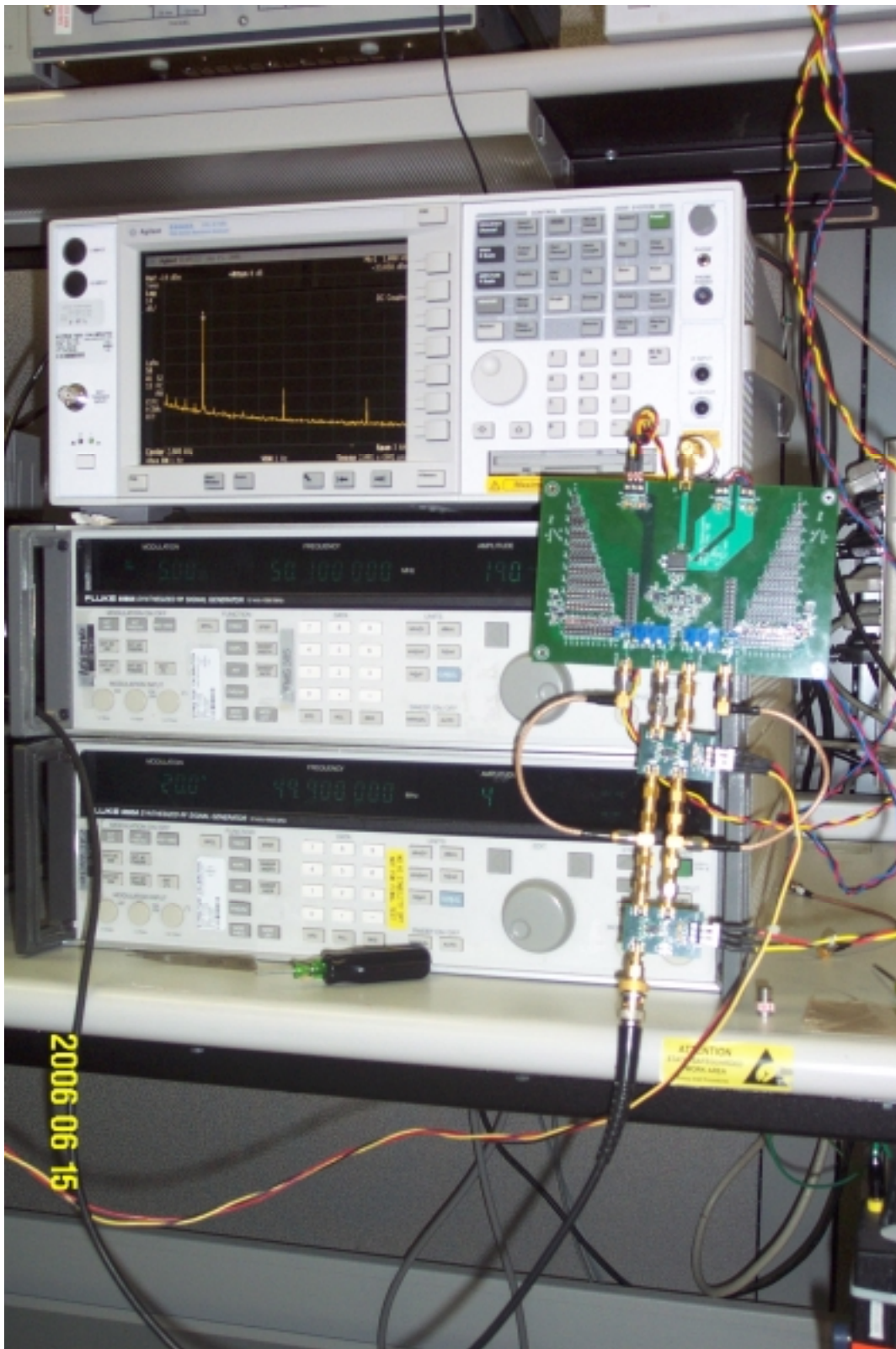


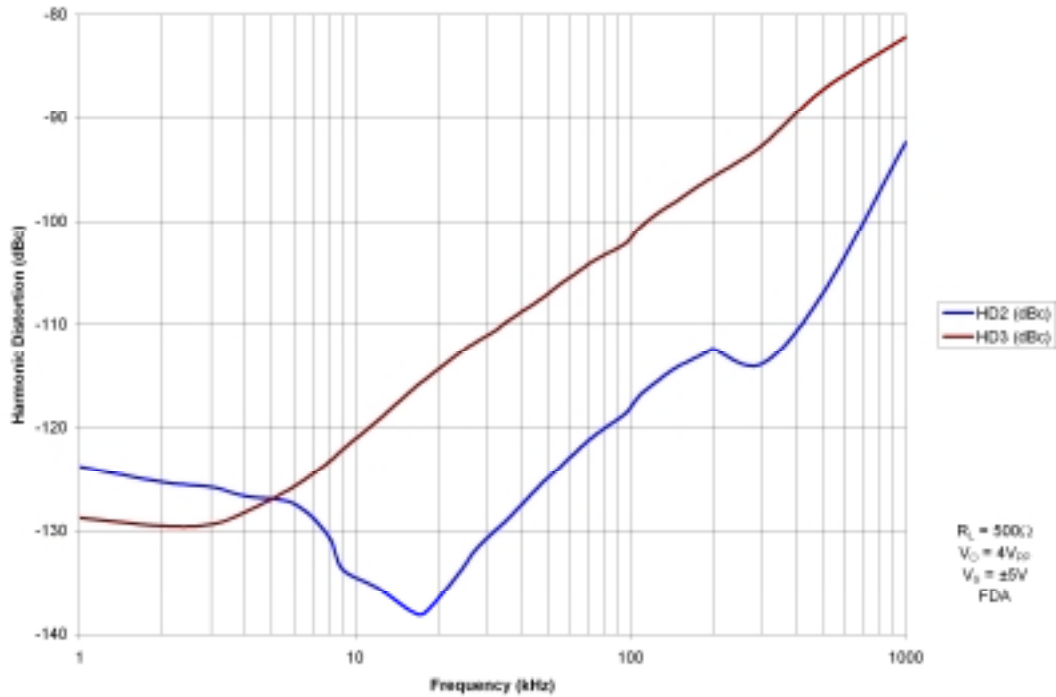
Fig. 26a: Fully-Differential Low-Frequency, Low-Distortion Measurement Technique



**Fig. 26b: Fully-Differential Test Board In The Test Environment**

The INA217 is not intended to drive that heavy a load ( $100\ \Omega$ ), so some characterization is required for the frequency band of interest. The INA217 may become a problem in the high-frequency band (greater than  $200\ \text{kHz}$ ) of the test. So we need to make sure that the difference between the fundamental residue and the measured harmonics is significantly smaller than the INA217 distortion. An alternative to driving the spectrum analyzer directly with the INA217 is to buffer it, with an OPA842 for example.

Figs. 27 to 30 show distortion test results of three, fully-differential amplifiers; the THS4131, the THS4503 and the THS4520.



**Fig. 27: THS4131  $V_S = \pm 5\ \text{V}$ ,  $V_O = 4\ \text{V}_{pp}$ ,  $R_{L\text{DIFF}} = 1\ \text{k}\Omega$ ,  $G_D = 1\ \text{V/V}$**

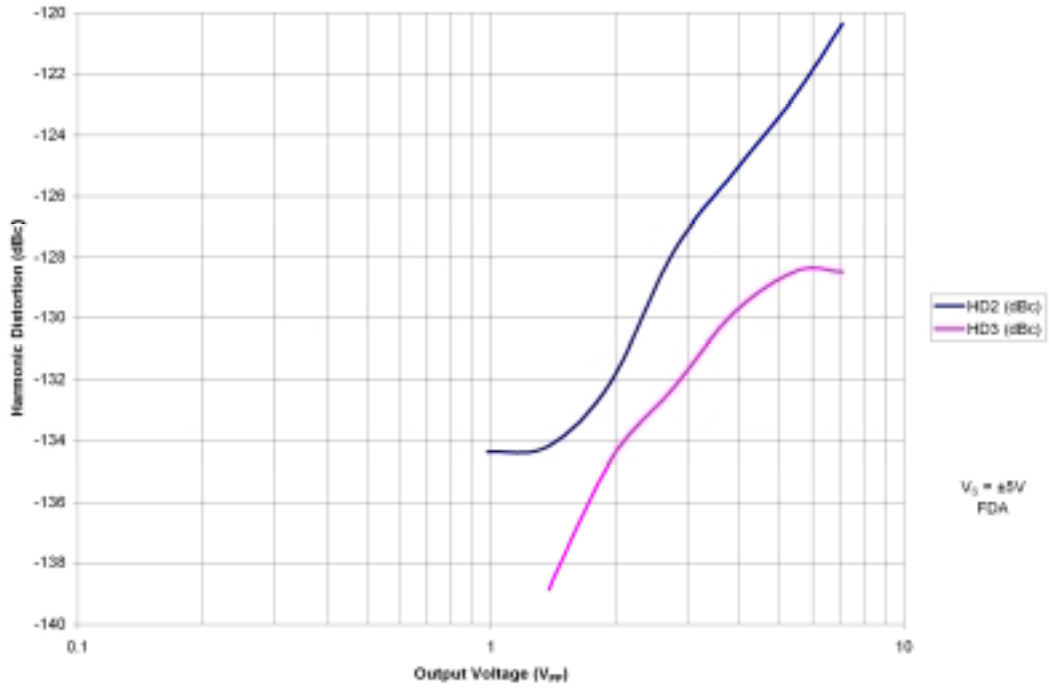


Fig. 28: THS4131 HD Vs.  $V_O$ ,  $R_{LDIFF} = 1\text{ k}\Omega$ ,  $f = 1\text{ kHz}$ ,  $V_S = \pm 5\text{ V}$ ,  $G_D = 1\text{ V/V}$

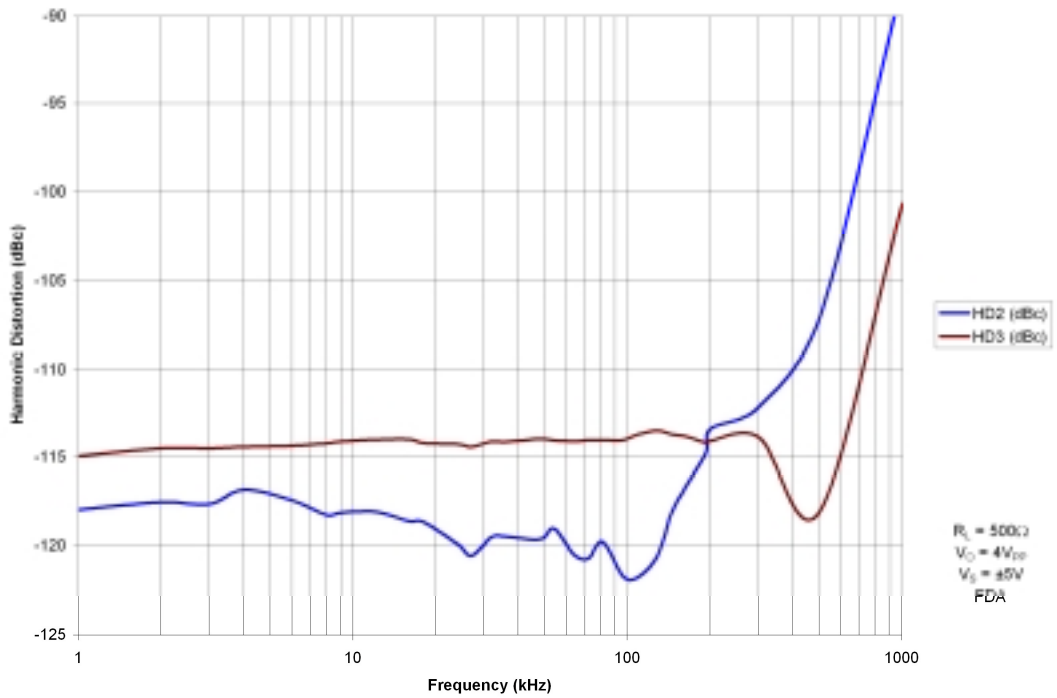
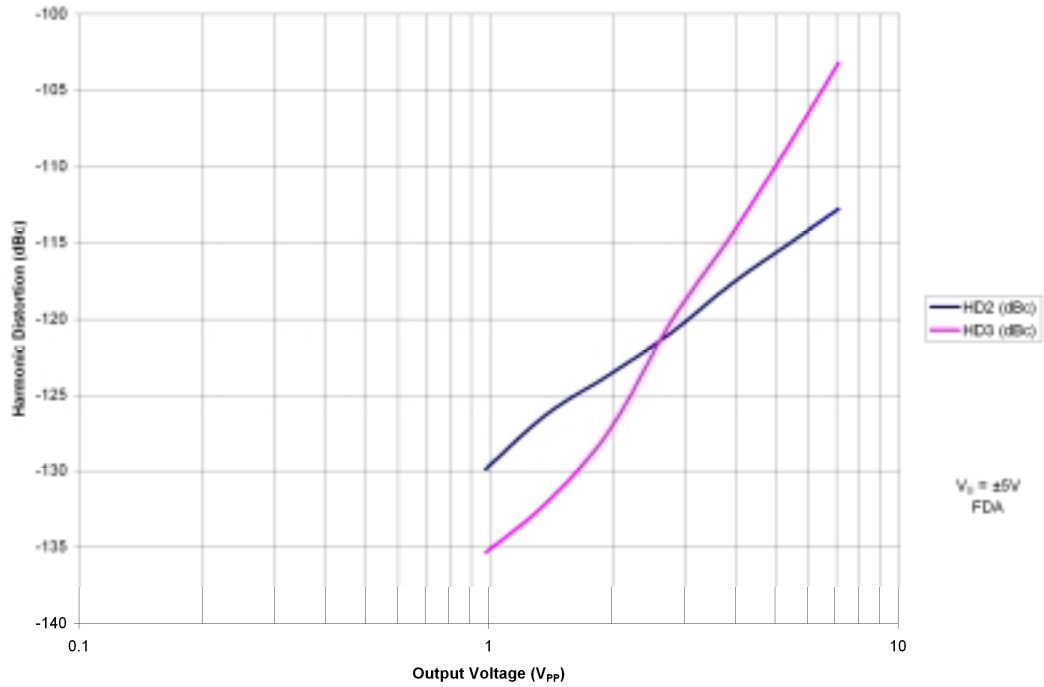
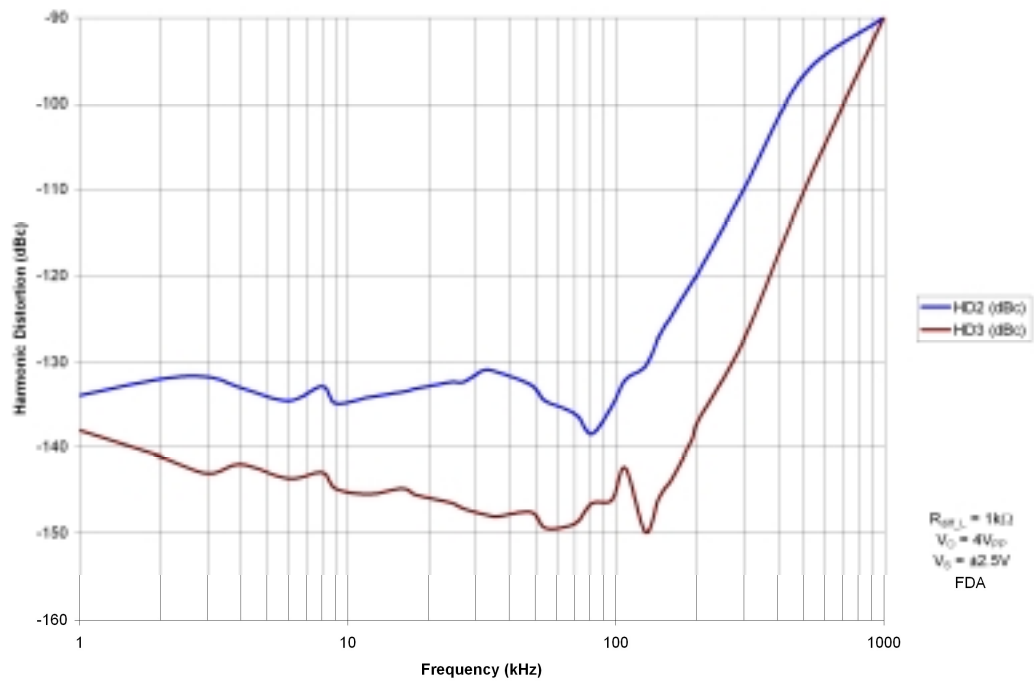


Fig. 29: THS4503  $V_S = \pm 5\text{ V}$ ,  $V_O = 4\text{ Vpp}$ ,  $R_{LDIFF} = 1\text{ k}\Omega$ ,  $G_D = 1\text{ V/V}$



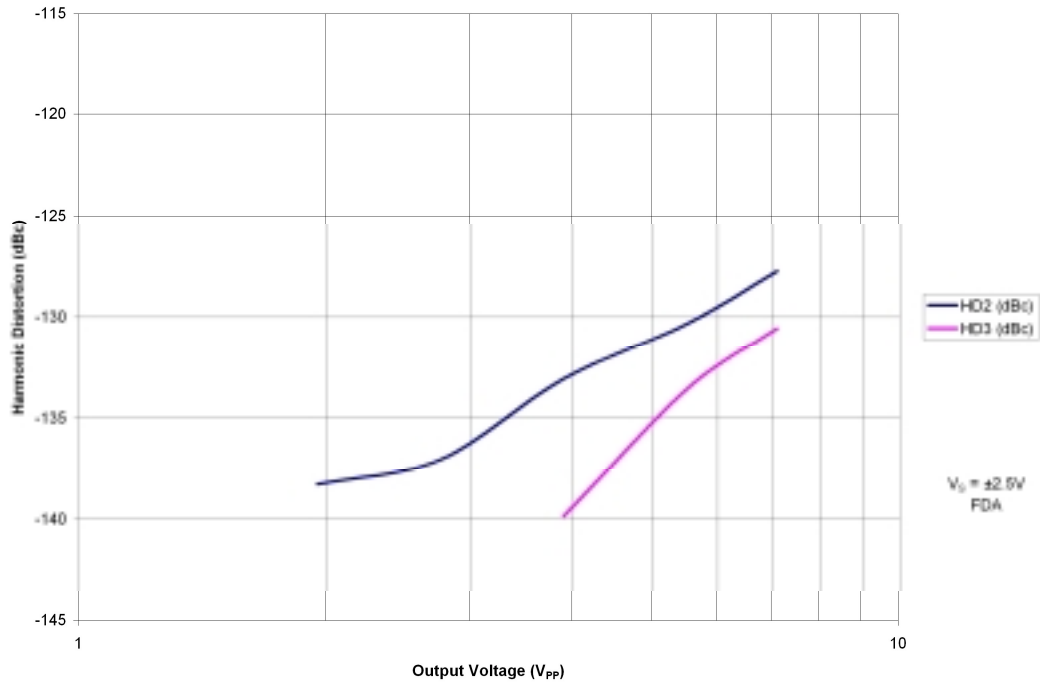
**Fig. 30: THS4503 HD Vs.  $V_O$ ,  $R_{LDIFF} = 1\text{ k}\Omega$ ,  $f = 1\text{ kHz}$ ,  $V_S = \pm 5\text{ V}$ ,  $G_D = 1\text{ V/V}$**

To be released in Q3 of 2006, the next fully-differential amplifier will be the THS4520.



**Fig. 31: THS4520 HD Vs. Frequency,  $R_{LDIFF} = 1\text{ k}\Omega$ ,  $V_O = 4\text{ Vpp}$ ,  $V_S = \pm 2.5\text{ V}$ ,  $G_D = 1\text{ V/V}$**

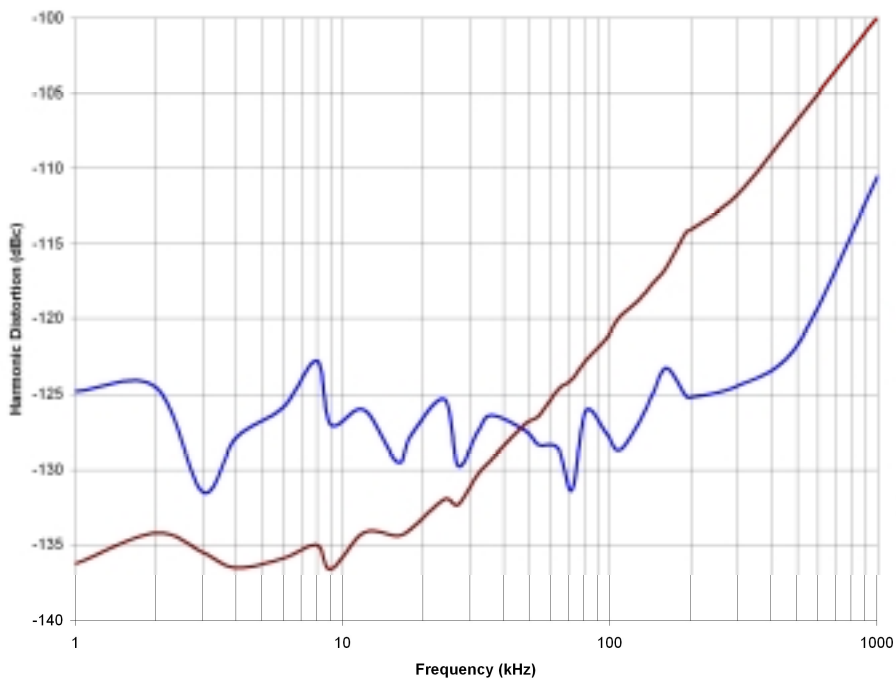




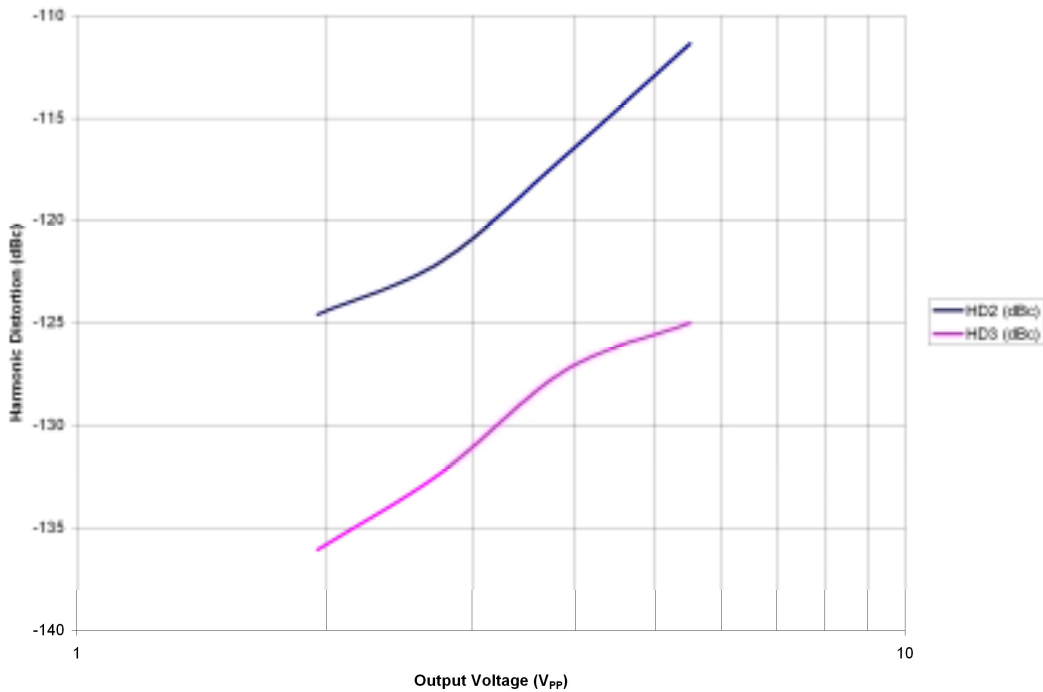
**Fig. 32: THS4520 HD Vs.  $V_O$ ,  $R_{LDIFF} = 1\text{ k}\Omega$ ,  $f = 1\text{ kHz}$ ,  $V_S = \pm 5\text{ V}$ ,  $G_D = 1\text{ V/V}$**

### Rail-To-Rail Amplifiers

If you are looking for better performance, rail-to-rail amplifiers may be the solution. The OPA830, shown in Figs. 33 and 34, has some of the best overall HD performance.



**Fig. 33: OPA830  $V_S = \pm 5\text{ V}$ ,  $R_L = 500\ \Omega$ ,  $V_O = 2\text{ Vpp}$**



**Fig. 34: OPA830  $V_S = \pm 5\text{ V}$ ,  $R_L = 500\ \Omega$ ,  $f = 1\text{ kHz}$**

## Summary

This TechNote has shown a new measurement method for low-frequency, low-distortion levels that gives advantages over commonly-used solutions. It also shows representative low-frequency distortion measurements for a range of device types.

## References

- (1) ADS8382 Datasheet <http://focus.ti.com/lit/ds/symlink/ads8382.pdf>
- (2) Application Note “Design Methodology for MFB Filters in ADC Interface Applications” <http://focus.ti.com/docs/toolsw/folders/print/mfbfilter-calc.html>

## About The Author

Xavier Ramus is an applications engineer for the high-speed signal conditioning product group at Texas Instruments, Tucson, AZ. He earned MSEE degrees from ESME-Sudria (Paris, France) and San Jose State University (San José, CA). His spare-time interests include history, antiques and running. He can be reached at [x-ramus2@ti.com](mailto:x-ramus2@ti.com).

