

PLANO BIAS

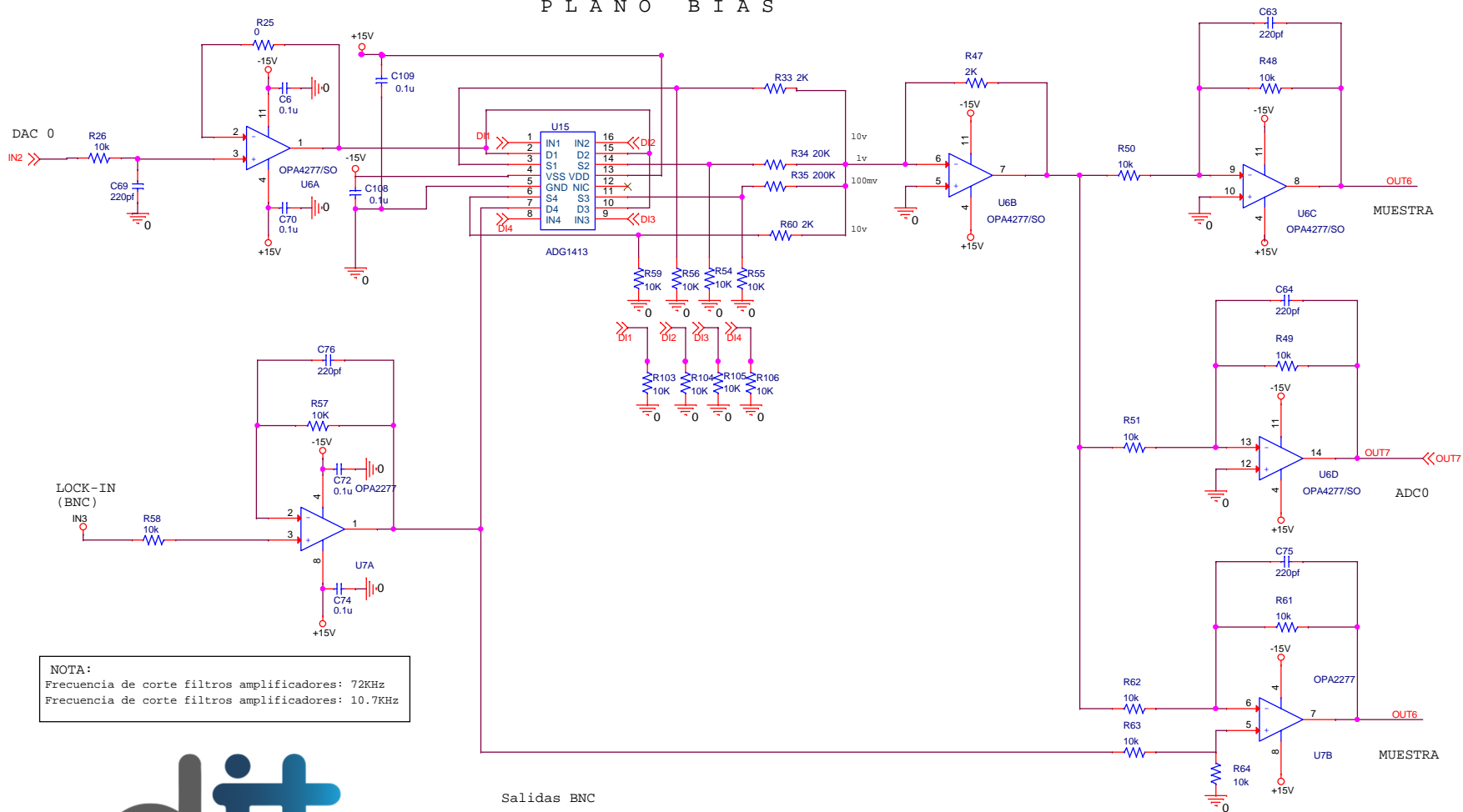

NOTA:
 Frecuencia de corte filtros amplificadores: 72KHz
 Frecuencia de corte filtros amplificadores: 10.7KHz



DISEÑO • INNOVACIÓN • TECNOLOGÍA

Salidas BNC

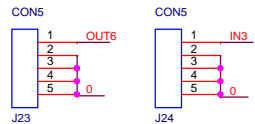

Title			<Title>
Size	Document Number	Rev	
Custom-Doc>		<RevCode>	
Date:	Tuesday, November 28, 2017	Sheet	1 of 1