

Tamara Alani and Richard Bartel

Introduction

Multiplexing is a technique that is frequently used to perform data acquisition in multichannel systems with minimal signal-chain requirements. In this context, the role of the multiplexer (MUX) in an acquisition system is to switch between channels, and send each signal to a single data converter as quickly as possible, thus maximizing system throughput and minimizing delay. To provide accurate processing, a precision amplifier is placed downstream from the multiplexer to precisely drive the analog-to-digital converter (ADC).

Traditional Amplifier Architecture

Traditional CMOS-input amplifier architectures consist of a differential transistor pair with the MOSFET sources connected together and then taken to ground via an active current source, as shown in [Figure 1](#). Modern transistor manufacturing techniques attempt to maximize MOSFET transconductance (g_m) by reducing oxide thickness (t_{ox}); however, this trade-off results in breakdown voltages of approximately 5 V from the gate to source. Large gate-to-source voltages typically stem from large input differential signals, which are commonly seen during slewing or open-loop operation. To protect the input from permanent damage, amplifiers have two robust antiparallel diodes between the inputs of the amplifier with a clamp voltage of typically ± 0.5 V to ± 1.5 V. These diodes limit the voltage swing across the inputs to one or two forward-diode voltage drops, which is well below the breakdown voltage. While these inputs provide a level of protection, the inputs also have considerable drawbacks.

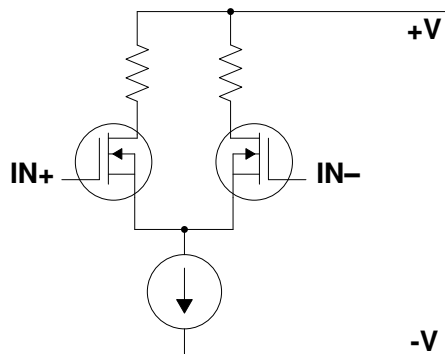

Figure 1. Transistor Differential Input Pair

Large Differential Inputs With Traditional Op Amps

[Figure 2](#) shows a MUX with two channels: A and B. When the output of the MUX is connected to channel A, 10 V is present at the noninverting input of the op amp. The amplifier operates linearly; therefore, the potential across the inputs is 0 V (neglecting offset voltage). As soon as the MUX switches from channel A to channel B, the noninverting input potential of the op amp instantly changes to -10 V. The op amp output voltage does not change instantly; a large differential voltage appears at the inputs, and the antiparallel diodes begin to conduct current. This action causes a sharp increase in input bias current and drop in input impedance. Without the input antiparallel diodes, this large differential voltage surpasses the breakdown voltage, and thus permanently damages the op amp. With the input antiparallel diodes, outlined in blue in [Figure 2](#), the inputs are protected from large differential voltages; however, large inrush current flows through the diodes. If passive filtering or high source impedance is present, large inrush current can disturb settling time, and thus limit system throughput and degrade signal-chain precision.

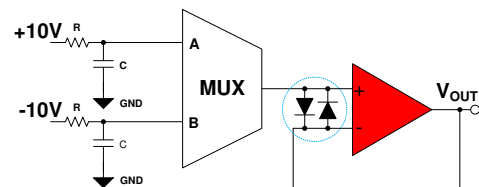

Figure 2. MUX With Buffer-Configured Op Amp

The op amp output settling time can be detrimental to high-speed or high-throughput applications. Most MUXes operate with nanosecond rise-times; far faster than most precision op amps. If the op amp slew rate cannot keep up with the MUX slew rate, a differential voltage develops, and settling time worsens as a result of input current. When the MUX switches between channels, an extended length of time is used for the output to respond to the input, and system performance may suffer. Some amplifiers attempt to solve this problem with high slew rate, but trade off power consumption and stability. TI's Precision Amplifier team developed a unique patented technology that combines high slew rate with a diode-

less front end to achieve accurate signal processing without the trade-offs of high-slew rate amplifiers. Device performance following a switched MUX is shown in **Figure 3**. Note the source-loading effects of a non-MUX-friendly amplifier (black) and a MUX-friendly amplifier (red). The top half of **Figure 3** illustrates the inrush of current, which can reach several tens or hundreds of milliamperes depending on the amplifier output current limit. The bottom half of **Figure 3** illustrates the effects of settling time while slewing. Although the traditional amplifier output moves quickly because of the input diodes, the RC-network settling is disturbed, and the system takes longer to settle.

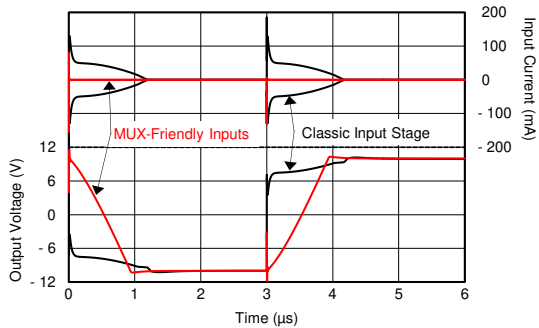

Figure 3. Switching Timing Diagram

MUX-Friendly Op Amps

Along with JFET input amplifiers that are inherently MUX-friendly, TI developed a new input circuitry for 36-V CMOS inputs that does not require antiparallel diodes for device protection. These MUX-friendly amplifiers maintain the same level of protection and robustness while improving settling time for switched systems. This patented input protection scheme uses a set of internal switches that open and close to protect the op amp input when large voltage steps are applied. This protection scheme has the added benefit of no inrush current. **Figure 4** shows this new MUX-friendly protection scheme in the quiescent state, with both switches closed and the diodes inactive.

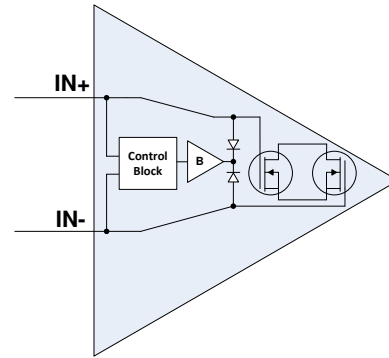

Figure 4. MUX-Friendly Scheme

When the positive input goes low (+10 V to -10 V), the control block opens the switch at the inverting terminal (IN-) and activates one of the diodes, illustrated in **Figure 5**. When the positive input goes high (-10 V to +10 V), the control block opens the switch at the noninverting terminal (IN+) and activates the other diode.

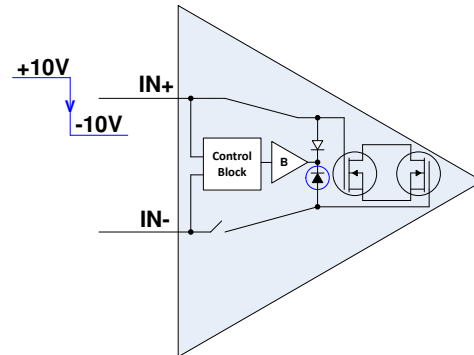

Figure 5. High-to-Low Input Step

The internal buffer op amp, labeled B, isolates the diode current from the input signal. The isolation prevents current from flowing through the input pins of the op amp. This new MUX-friendly architecture prevents any additional settling time. With this configuration, systems can quickly switch between MUX channels without compromising precision.

Additional Resources

Table 1. TI MUX-Friendly Amplifiers

Device	Optimized Parameters
OPA2182	Industry's lowest offset drift (0.012 $\mu\text{V}/^\circ\text{C}$, max), 5.7-nV/ $\sqrt{\text{Hz}}$, MUX-friendly, 36-V op amp
OPA191	CMOS-input, 25- μV offset max, 0.8- $\mu\text{V}/^\circ\text{C}$ drift max, 2.5-MHz, 200- μA supply current max
OPA192	CMOS-input, 25- μV offset max, 0.5- $\mu\text{V}/^\circ\text{C}$ drift max, 10-MHz, 1.2-mA supply current max
OPA189	CMOS-input, 2.5- μV offset max, 0.02- $\mu\text{V}/^\circ\text{C}$ drift typ, 14-MHz, 1.7-mA supply current max
OPA145	JFET-input, 150- μV offset max, 1- $\mu\text{V}/^\circ\text{C}$ drift typ, 5.5-MHz, 475- μA supply current max
OPA828	JFET-input, 300- μV offset max, 1.5- $\mu\text{V}/^\circ\text{C}$ drift typ, 45-MHz, 5.5-mA supply current max

IMPORTANT NOTICE AND DISCLAIMER

TI PROVIDES TECHNICAL AND RELIABILITY DATA (INCLUDING DATASHEETS), DESIGN RESOURCES (INCLUDING REFERENCE DESIGNS), APPLICATION OR OTHER DESIGN ADVICE, WEB TOOLS, SAFETY INFORMATION, AND OTHER RESOURCES "AS IS" AND WITH ALL FAULTS, AND DISCLAIMS ALL WARRANTIES, EXPRESS AND IMPLIED, INCLUDING WITHOUT LIMITATION ANY IMPLIED WARRANTIES OF MERCHANTABILITY, FITNESS FOR A PARTICULAR PURPOSE OR NON-INFRINGEMENT OF THIRD PARTY INTELLECTUAL PROPERTY RIGHTS.

These resources are intended for skilled developers designing with TI products. You are solely responsible for (1) selecting the appropriate TI products for your application, (2) designing, validating and testing your application, and (3) ensuring your application meets applicable standards, and any other safety, security, or other requirements. These resources are subject to change without notice. TI grants you permission to use these resources only for development of an application that uses the TI products described in the resource. Other reproduction and display of these resources is prohibited. No license is granted to any other TI intellectual property right or to any third party intellectual property right. TI disclaims responsibility for, and you will fully indemnify TI and its representatives against, any claims, damages, costs, losses, and liabilities arising out of your use of these resources.

TI's products are provided subject to TI's Terms of Sale (www.ti.com/legal/termsofsale.html) or other applicable terms available either on ti.com or provided in conjunction with such TI products. TI's provision of these resources does not expand or otherwise alter TI's applicable warranties or warranty disclaimers for TI products.

Mailing Address: Texas Instruments, Post Office Box 655303, Dallas, Texas 75265
Copyright © 2020, Texas Instruments Incorporated