

Main Supply Line to SMPS

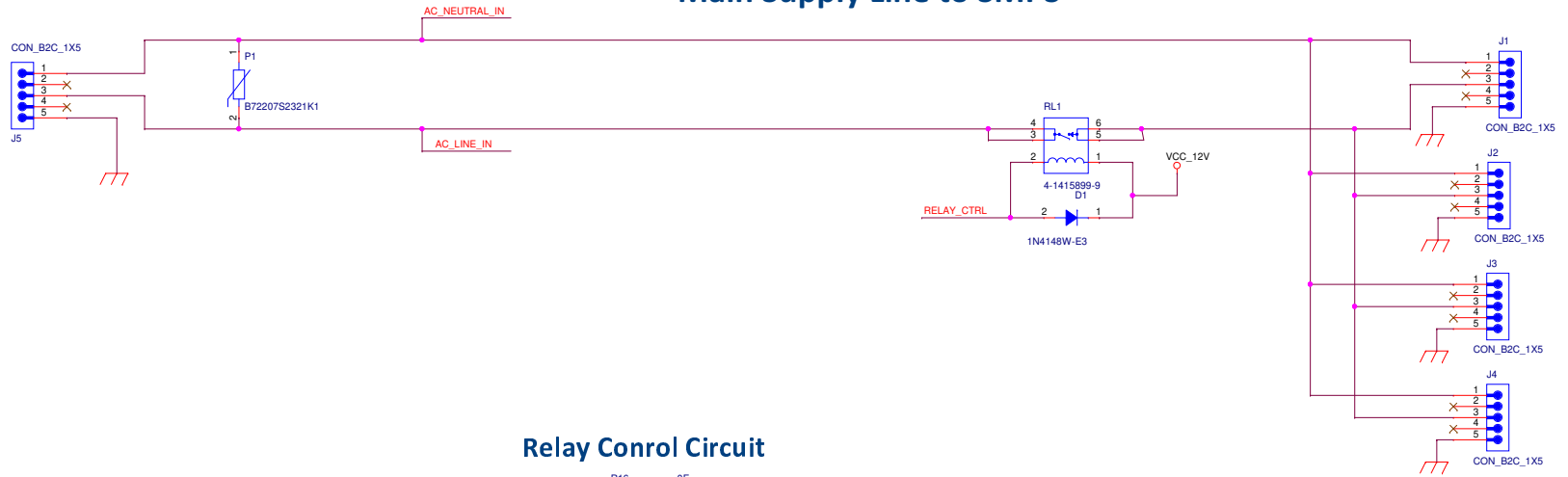

Relay Control Circuit

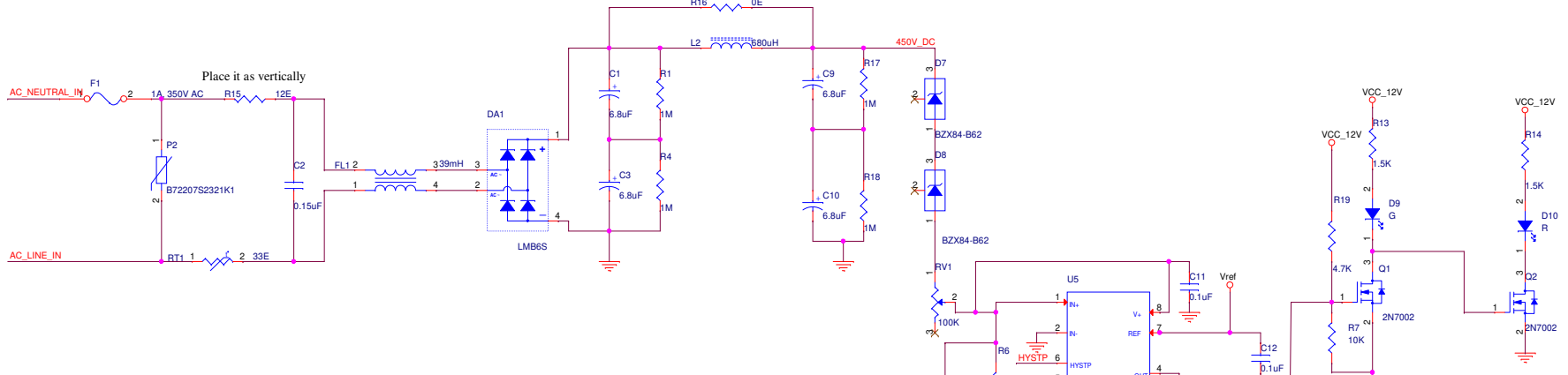

LNK306

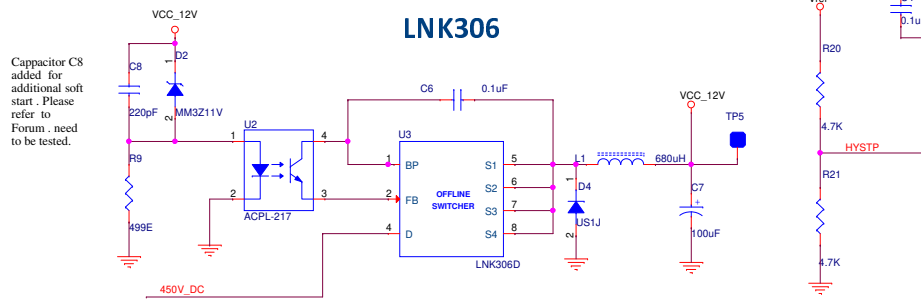

Capacitor C8 added for additional soft start. Please refer to Forum, need to be tested.

<Variant Name>

| | | | |
|-------|---------------------------|-------------|--------|
| Title | | OVP Circuit | |
| Size | Document Number | 501-1-01039 | Rev |
| A3 | | | A1 |
| Date: | Monday, November 18, 2019 | Sheet | 3 of 4 |