

7-PORT ETHERNET SWITCH

JUMPER FOR I2C,SPI SELECTION

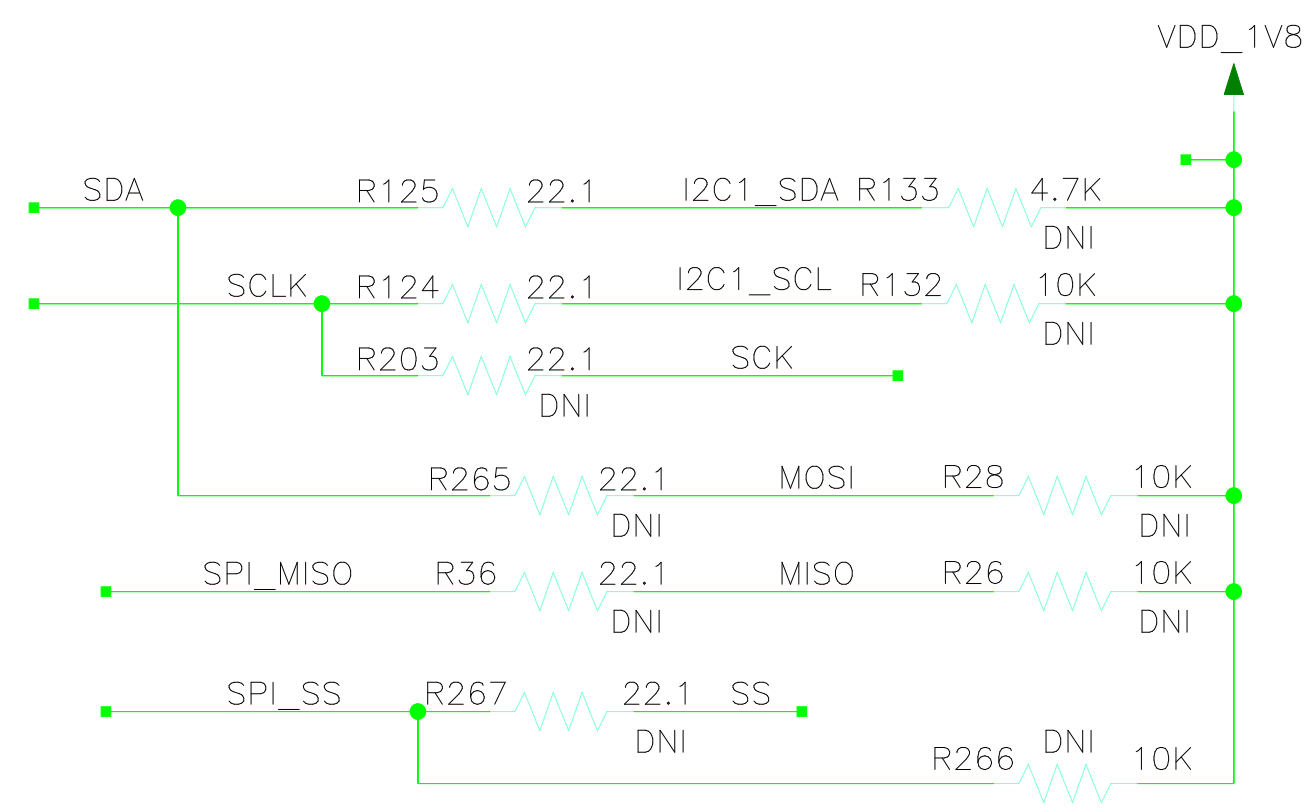

Note --
Place all 22E at Source side

Port Sharing b/w SFP & 10BaseT-L

PHY-PORT-A

10-Base-B

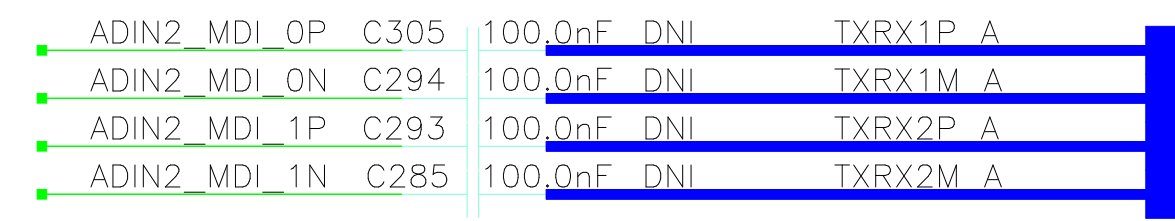

10-Base-A

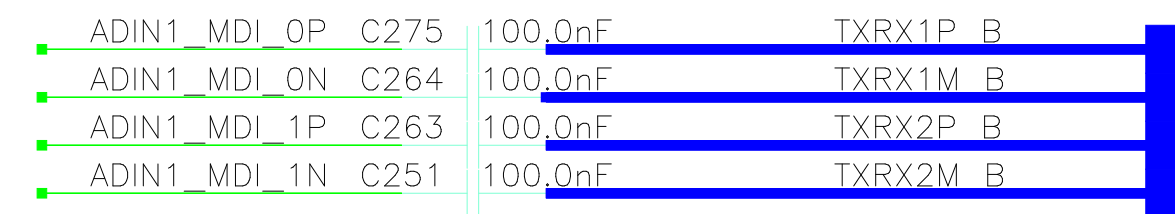

PHY PORT-B

Note :

-The device provides the option to add a minimum of 1.5ns internal delay to either TX_CLK6 or RX_CLK6, via the RGMII .Internal Delay control bits in the XMIIPort Control 1 Register. This can reduce or eliminate the need to add trace delay to the clock signals on the printed circuit board. RGMII_ID_ig enables delay on TX_CLK6, and the default is off. RGMII_ID_eg enables delay on RX_CLK6, and the default is on

-KSZ9477S provides internal biasing and termination
-Default configuration selection for KSZ9477S is I2C

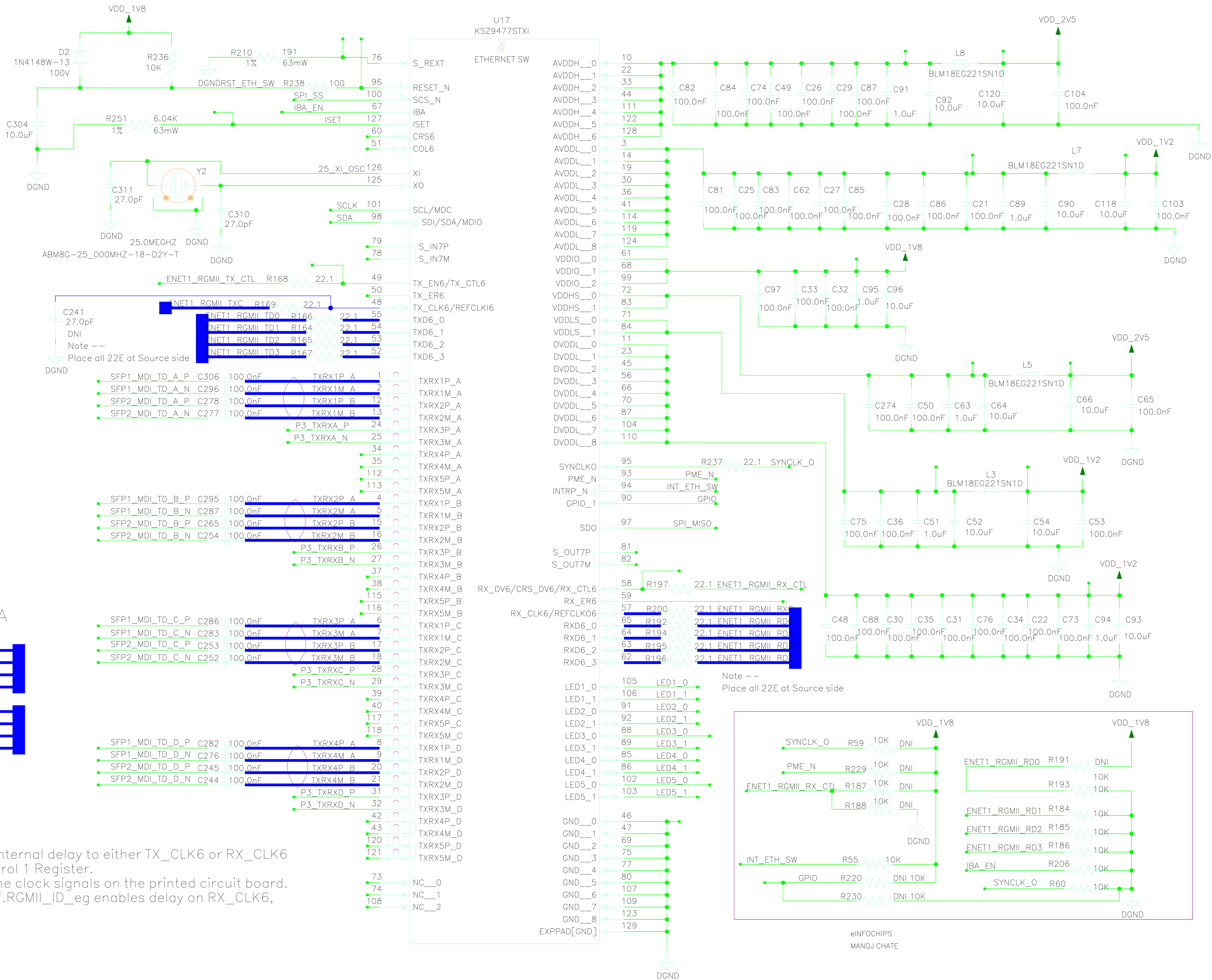

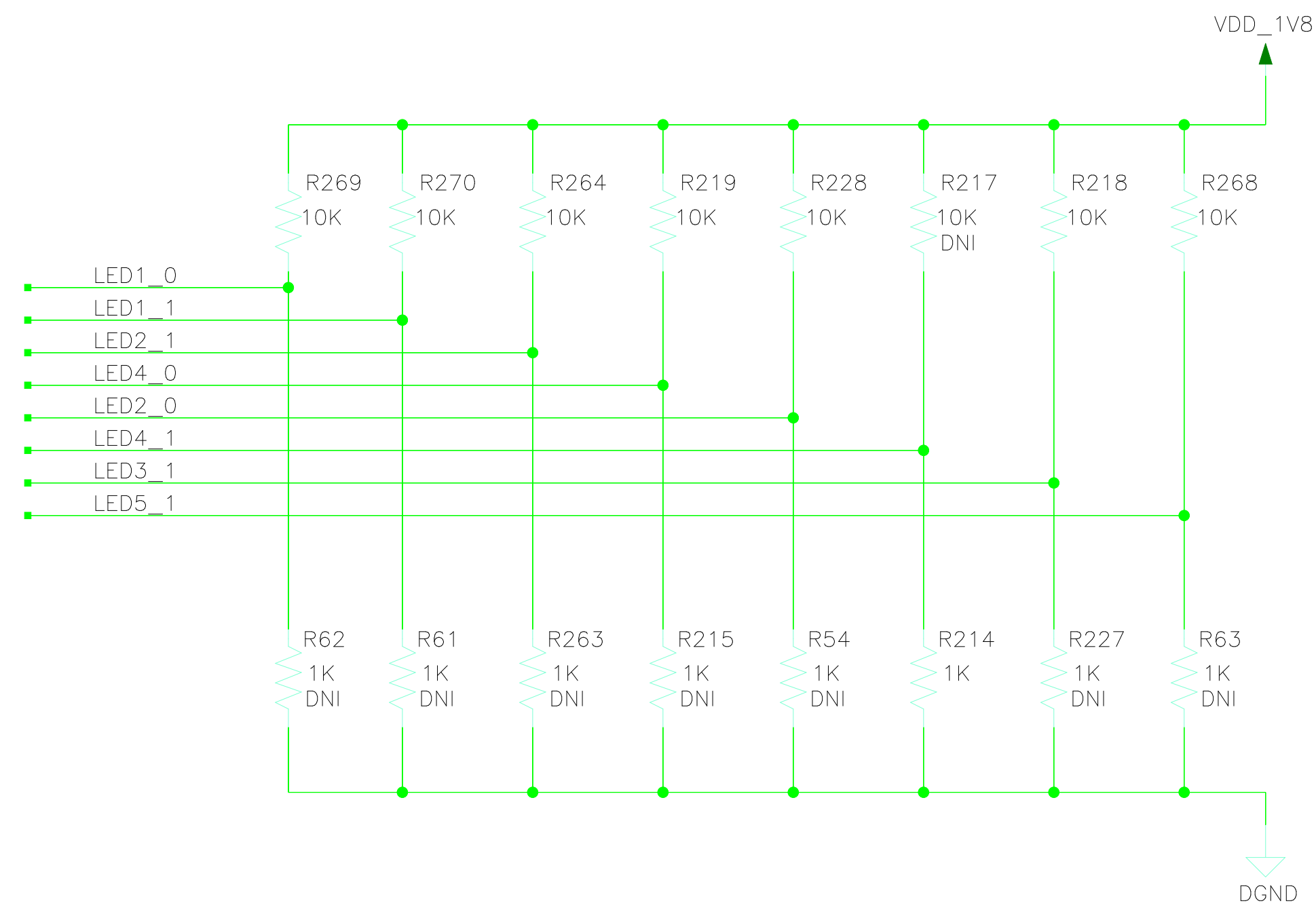

CONFIGURATION STRAP FOR 7-PORT SWITCH

GRXD0	RGMI: 1000Mb/s
LED2_0	1000B-T MASTER OR 10/100 MDI
LED4_0	ENABLE AN OR 100B-TX
LED1_0	QUITE-WIRE OFF
LED1_1	FLOW CONTROL ON
LED2_1	NORMAL LINK UP
LED4_1	I2C
LED5_1	START SWITCH
IBA	IBA OFF

KSZ9477S CONFIGURATION STRAPPING OPTIONS

7-PORT SWITCH JITTER BLOCKER AND SYNC HEADER

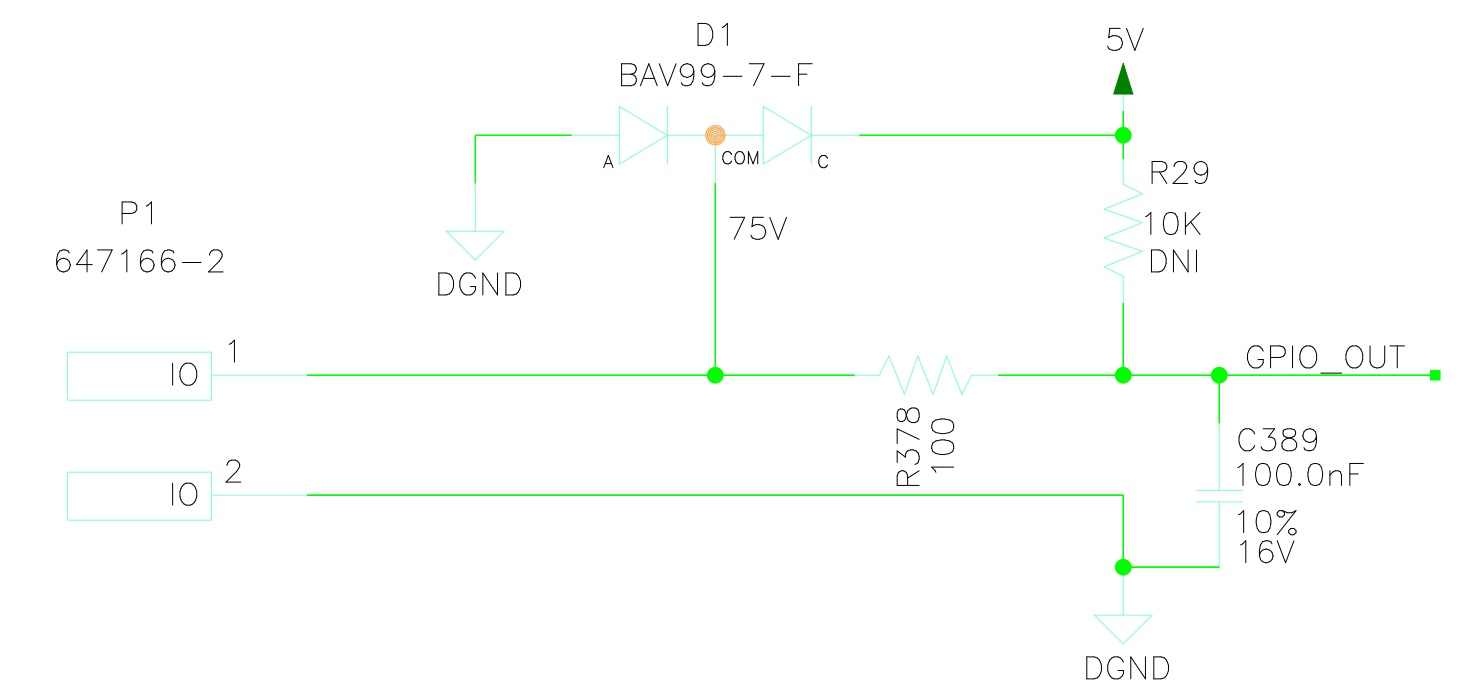
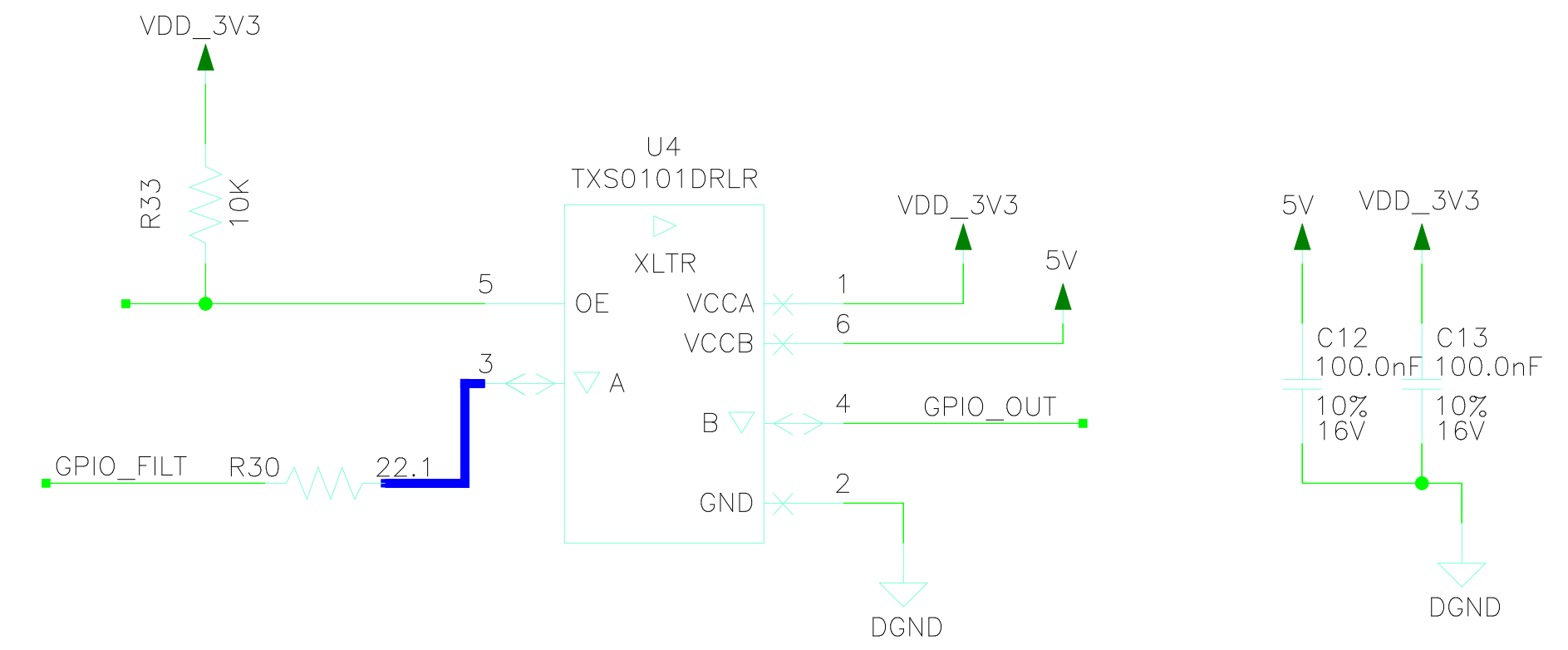
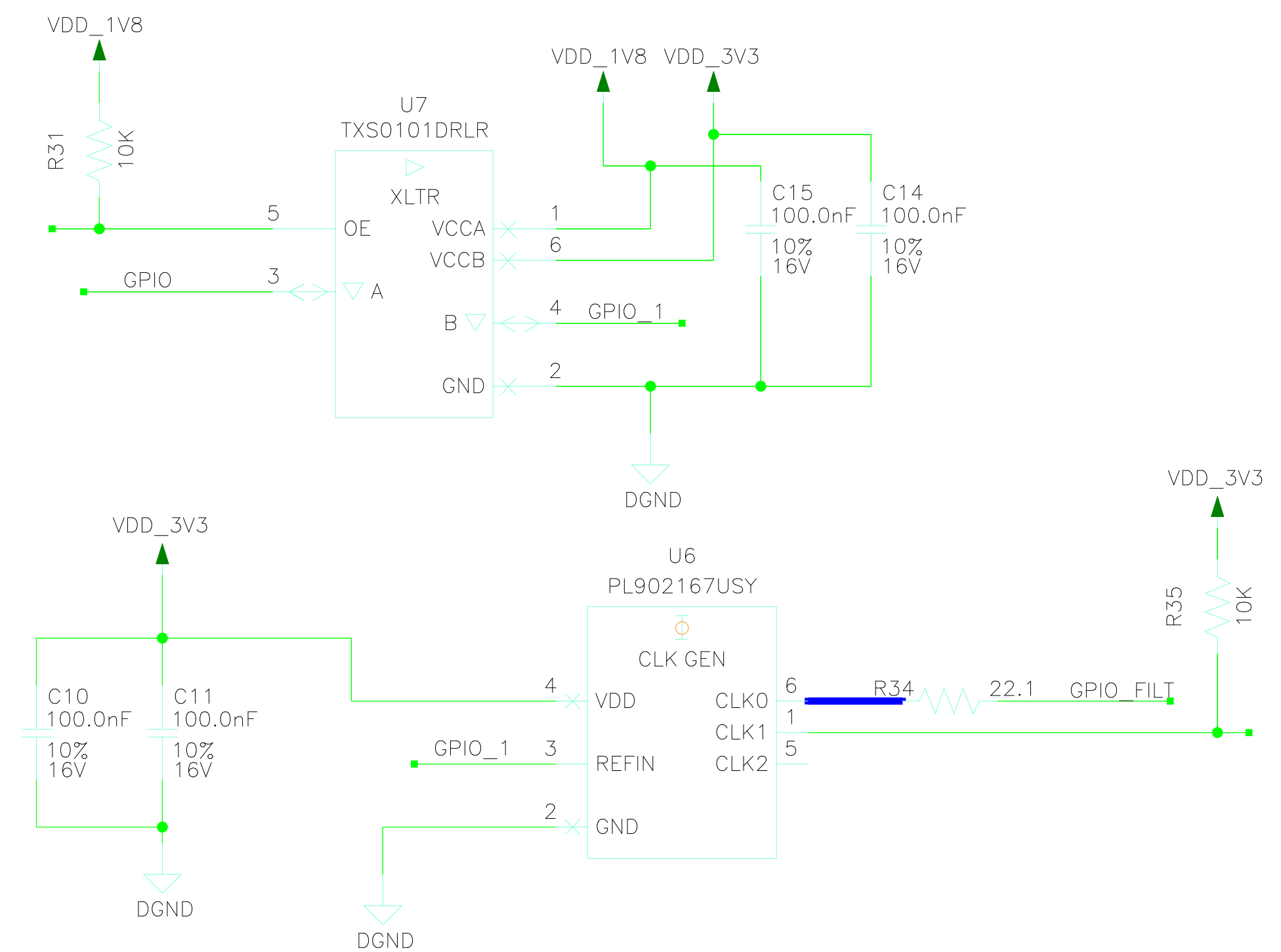

SYNC HEADER

eINFOCHIPS
MANOJ CHATE

3.3V <-> 1.8V : SPI & MDIO SIGNAL LEVEL SHIFTER

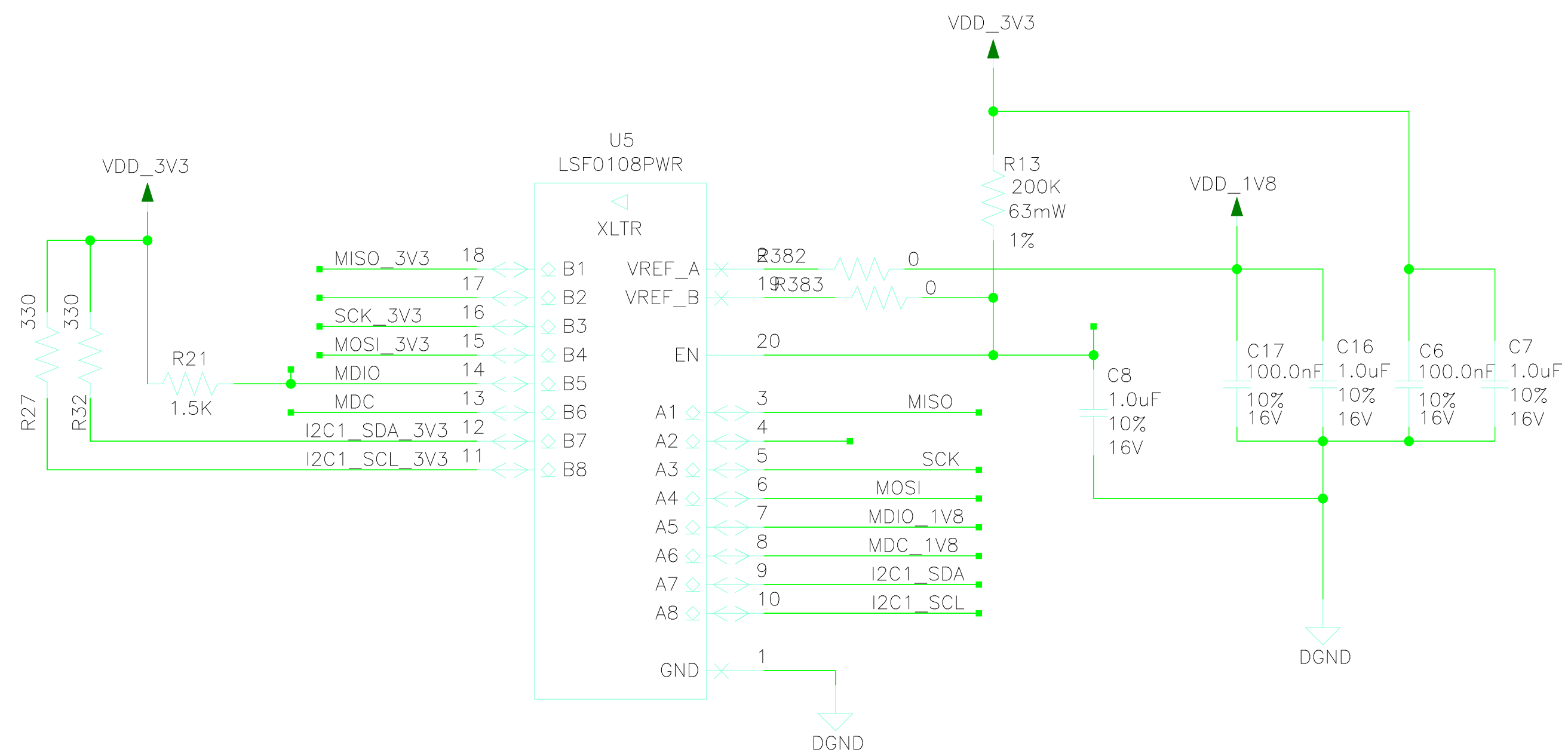

FIDUCIALS

- 1 FD4 INSTPAR
- 1 FD1 INSTPAR
- 1 FD2 INSTPAR
- 1 FD6 INSTPAR
- 1 FD3 INSTPAR
- 1 FD5 INSTPAR

SFP-A

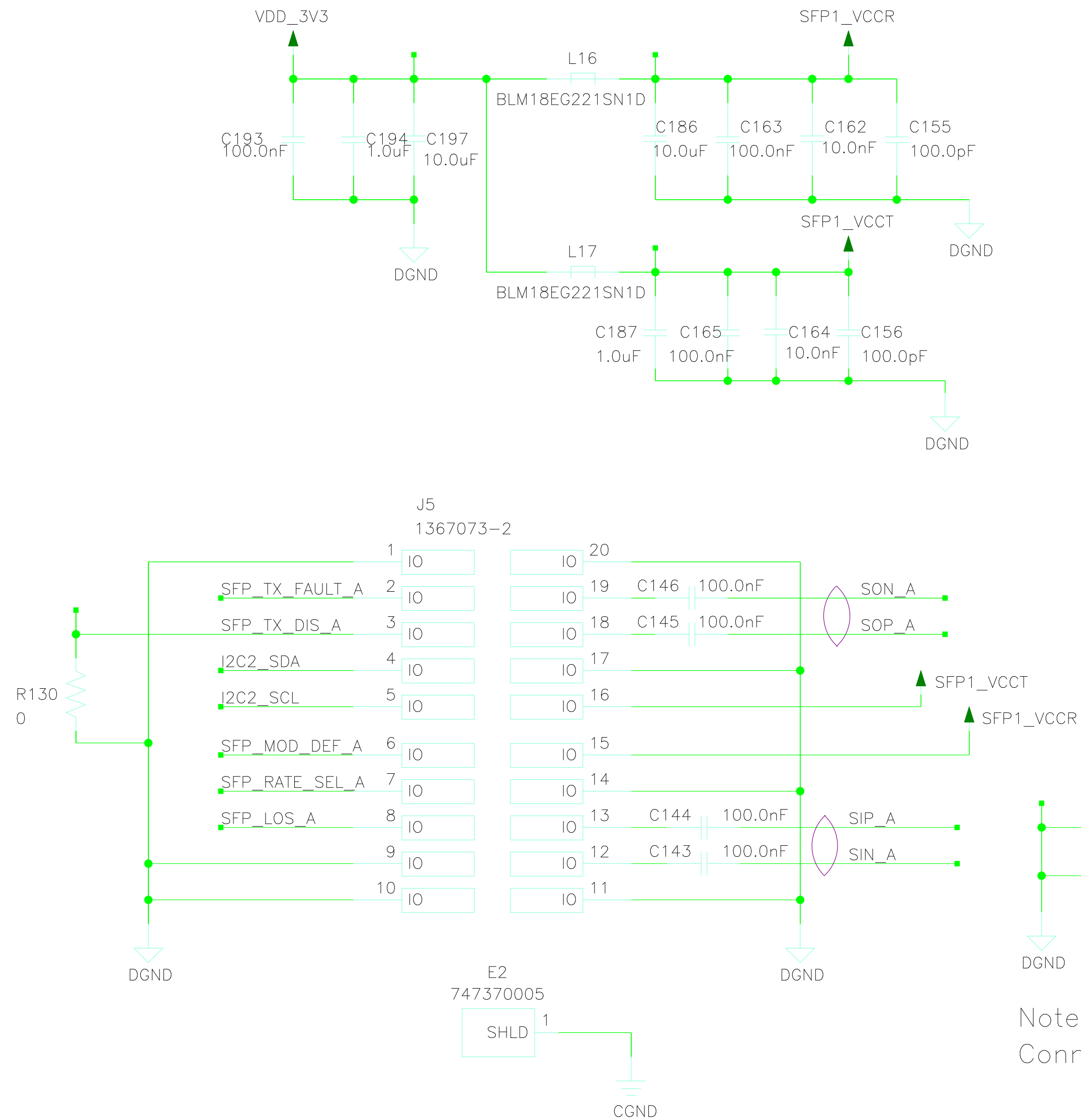

SFP-B

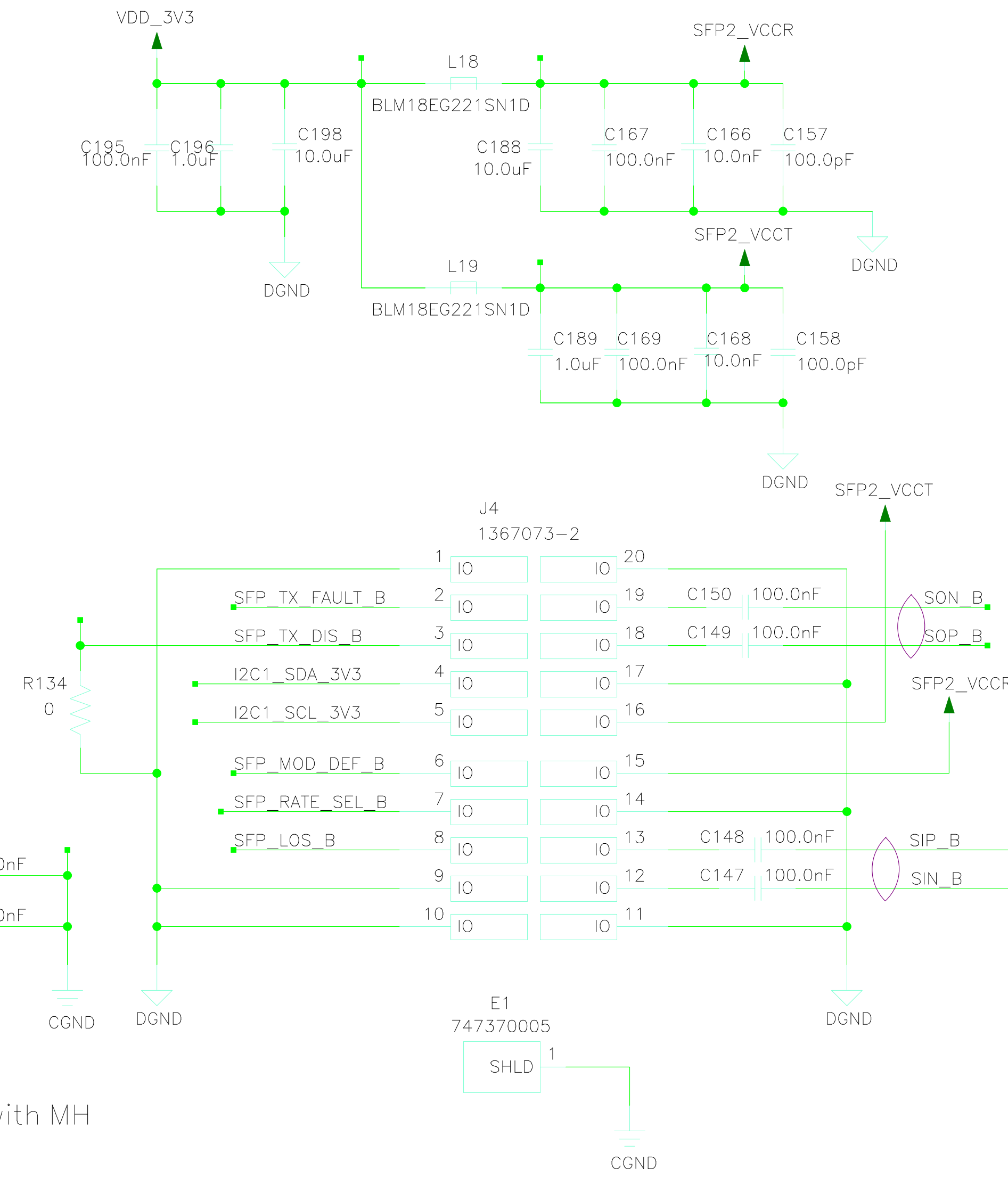

Note --
Connect CGND with MH

Note --

** C299-C302 can be mounted as 0E ,
Since SFP transceiver has inbuilt coupling capacitor

**C445-C448 can be mounted as 0E ,
Since SFP transceiver has inbuilt coupling capacitor

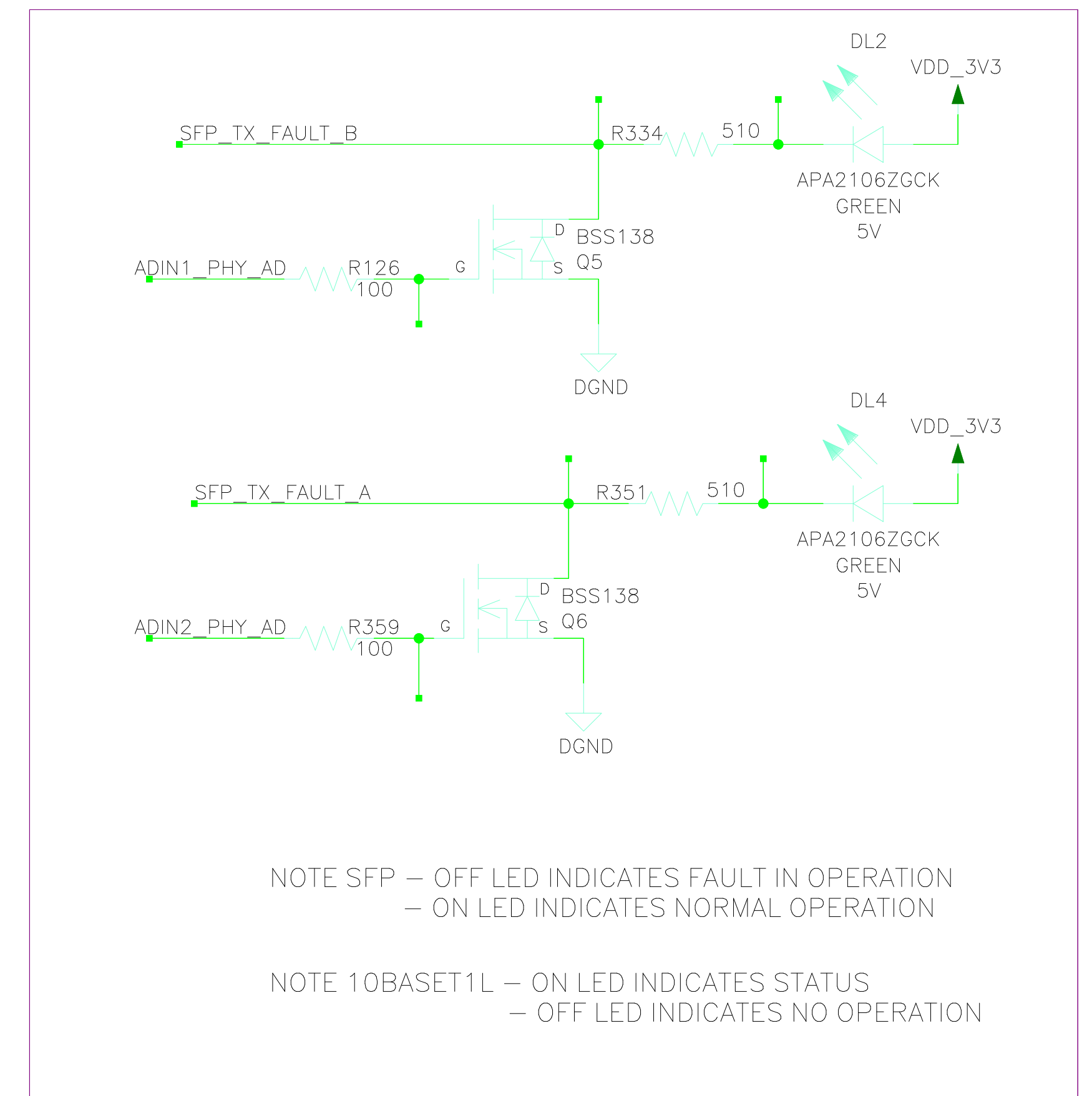
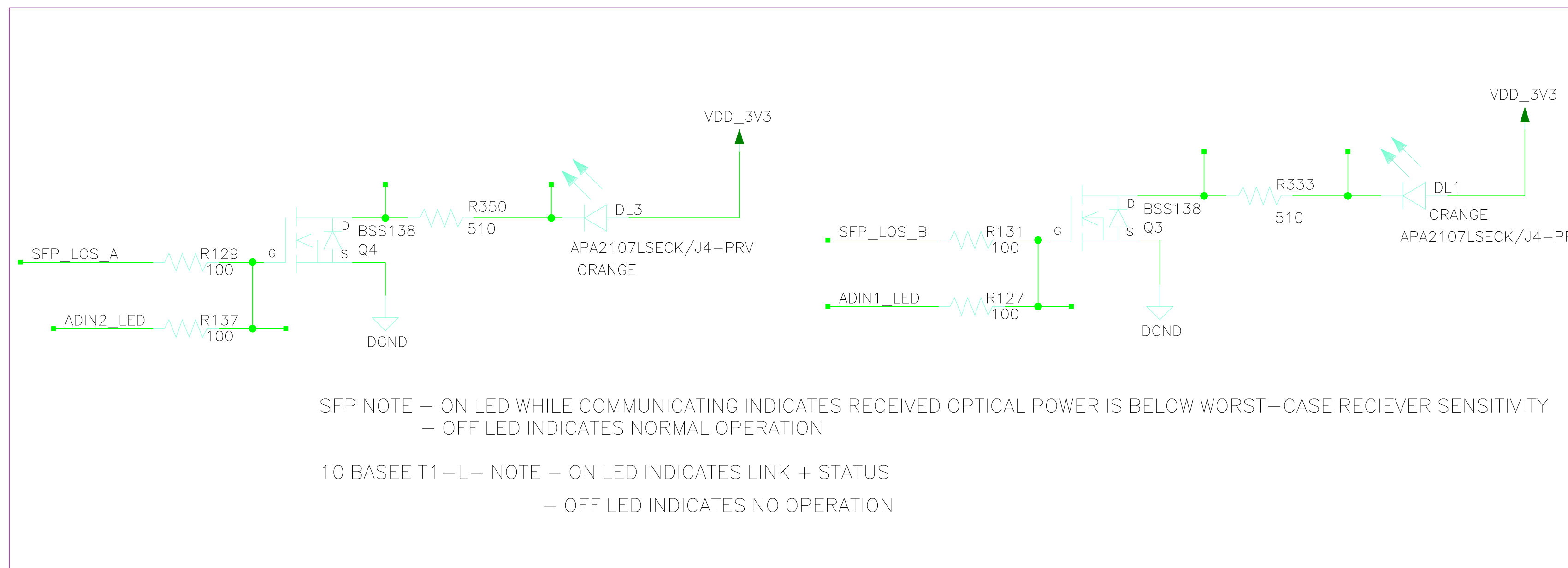

eINFOCHIPS
MANOJ CHATE

BOARD TO BOARD CONNECTOR

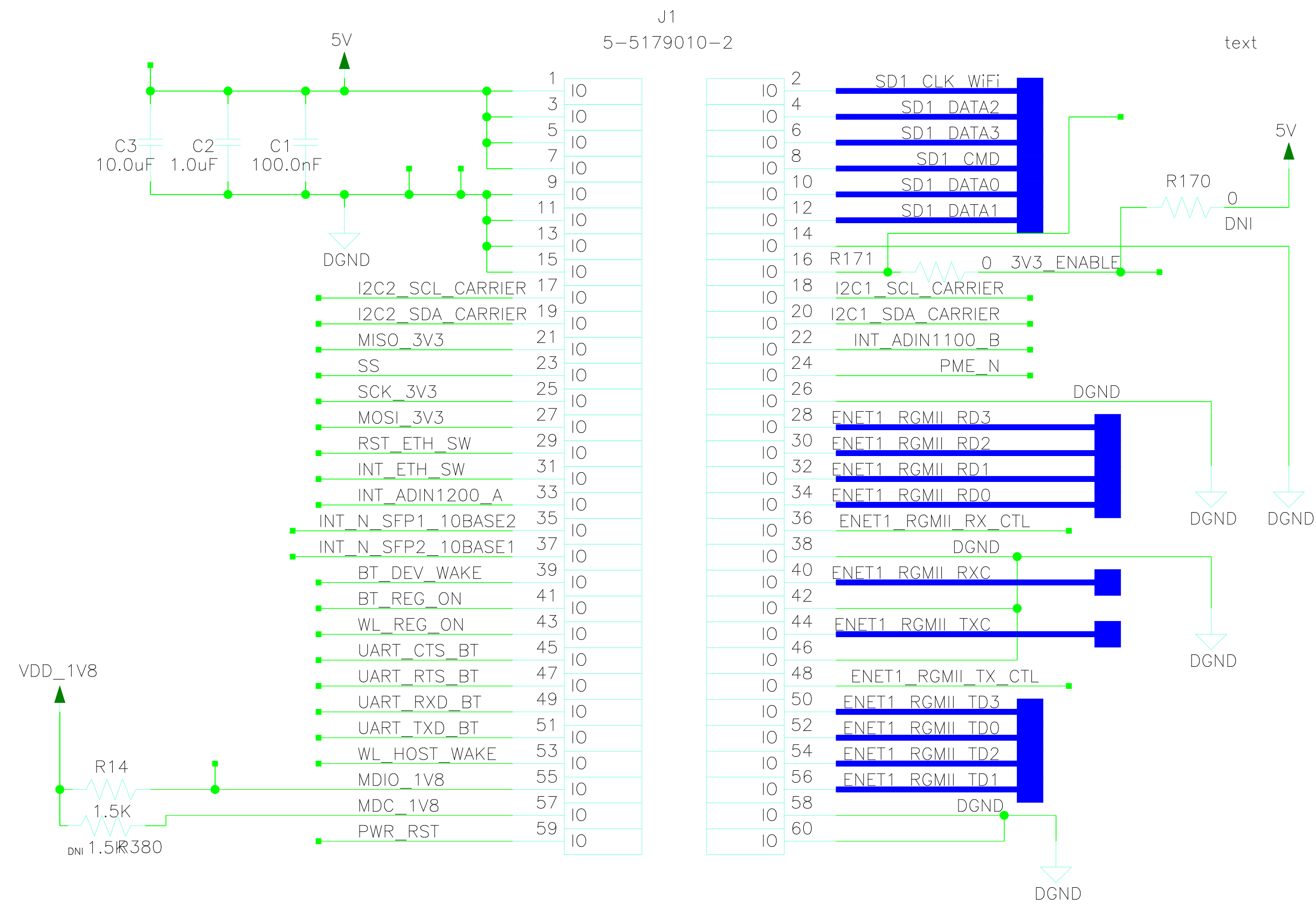

GPIO EXPANDER

I2C ADDRESS : 0100000X

NOTE : All ports are defined as inputs on power-on

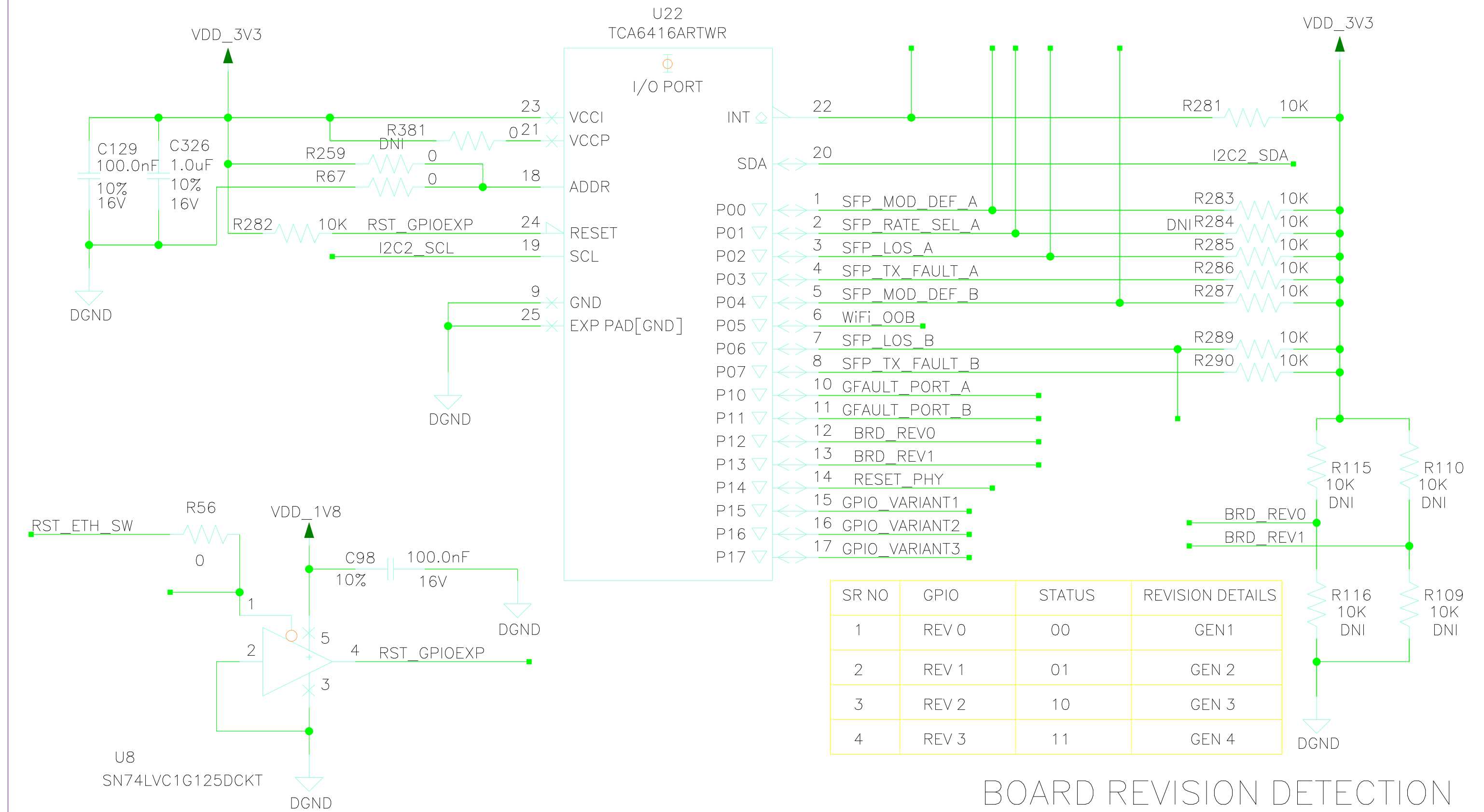

BOARD REVISION DETECTION

I2C BUFFER

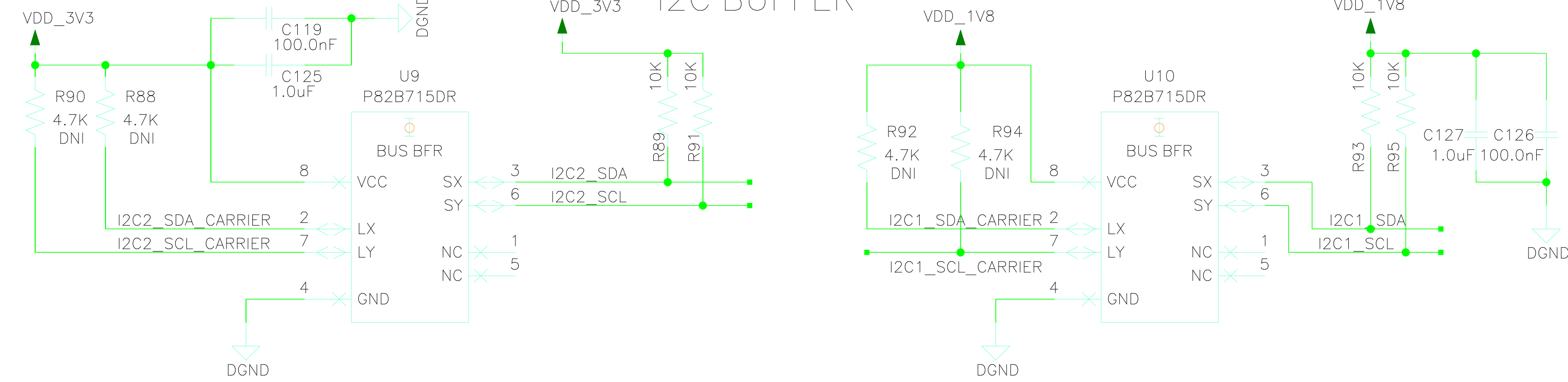

ASSEMBLY VARIANT DETECTION

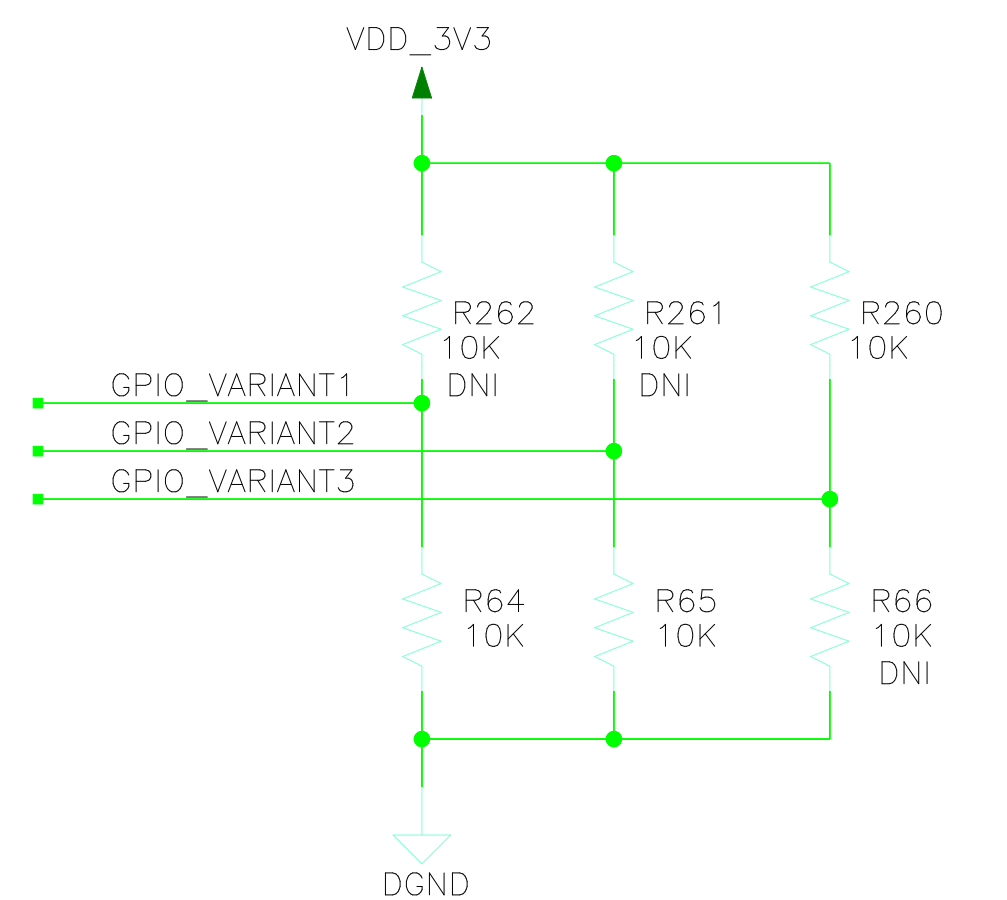

MOUNTING HOLES

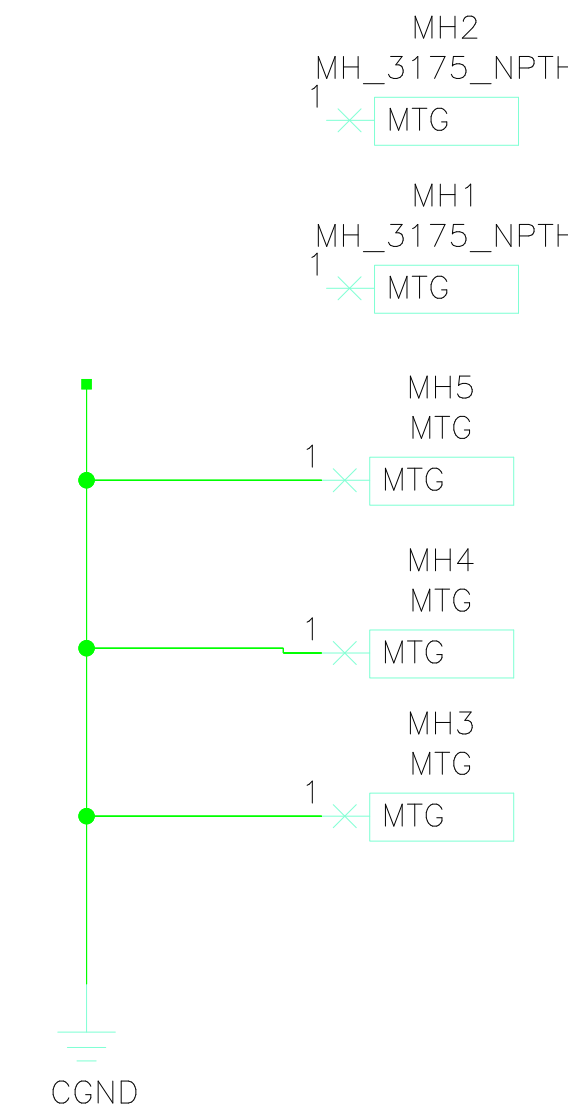

3.3V ↔ 1.8V BT UART SIGNAL LEVEL SHIFTER

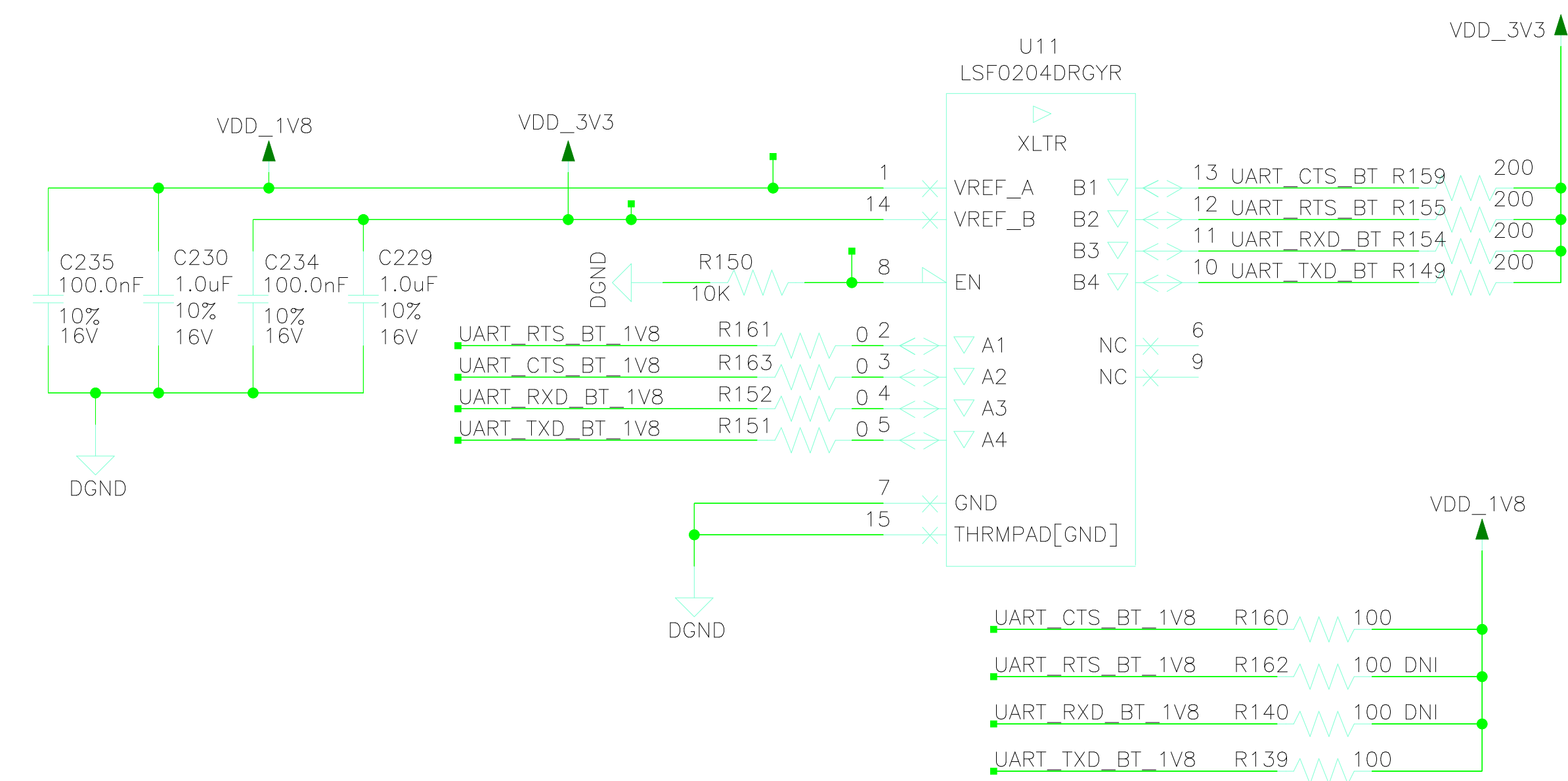

eINFOCHIPS
MANOJ CHATE