

# FIRST PCB

PCB have 5V switch step down DC-DC regulator and 3.3V LDO regulator

# SECOND PCB

PCB have 3.3V LDO regulator. Gets 5V from first PCB from header

The two pcbs connected directly (Male header master- Female header slave)

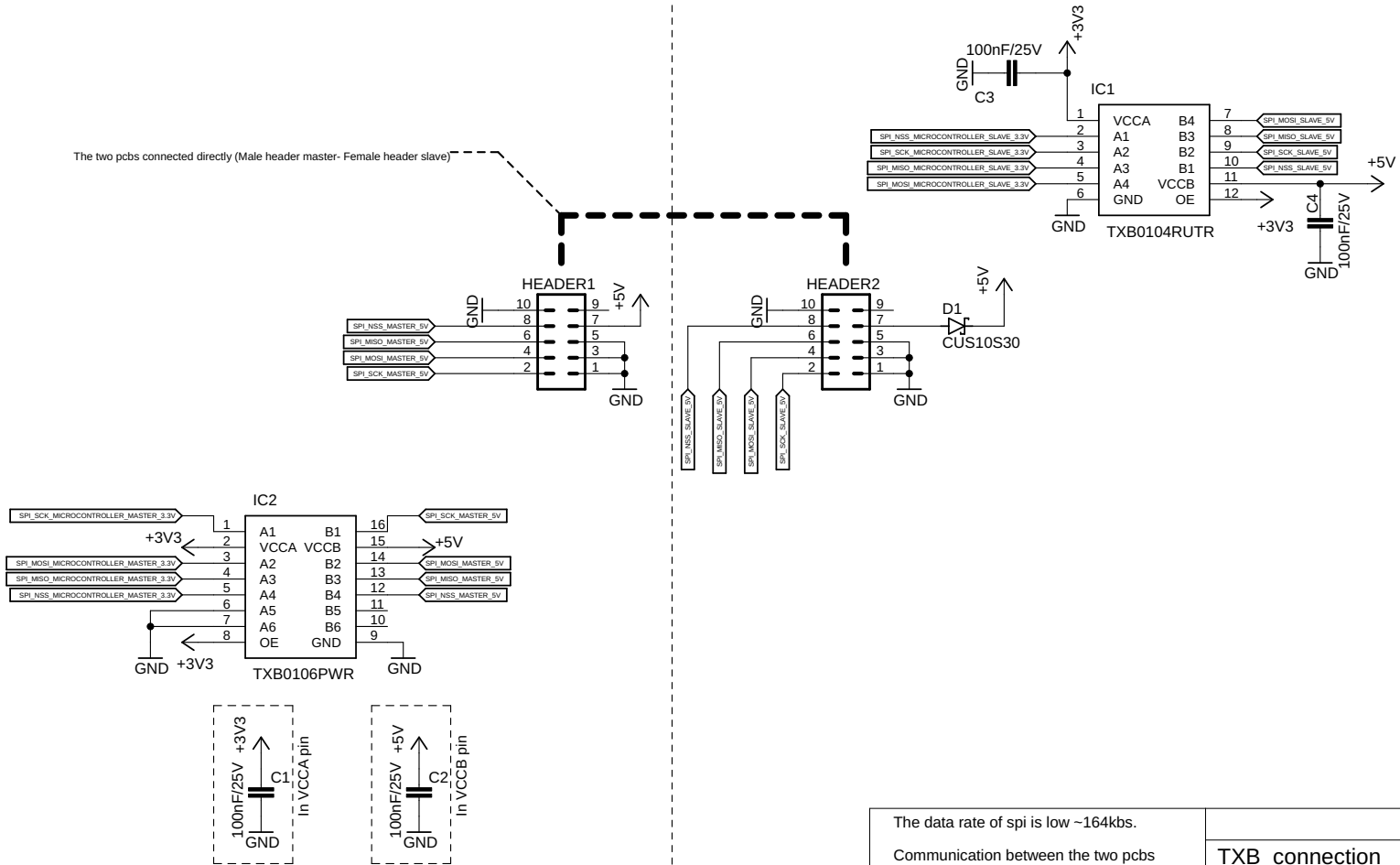

The data rate of spi is low ~164kbs.  
 Communication between the two pcbs works well without any problems. The two pcbs exchange packets without any lost.

TXB_connection	
30/4/2020 11:31 μμ	
Sheet:	1/1