

Board-A

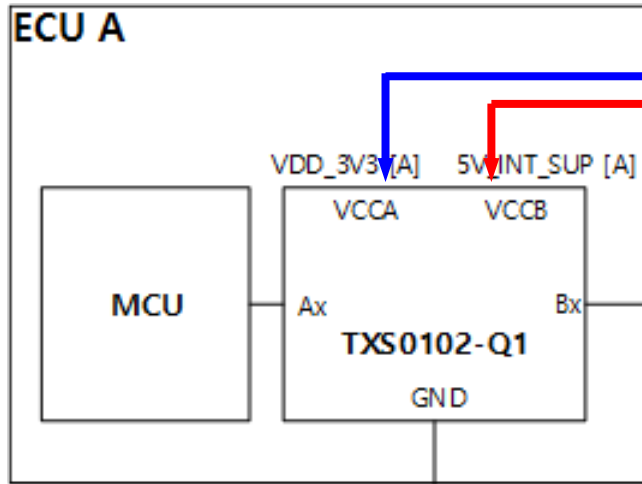

Board-B

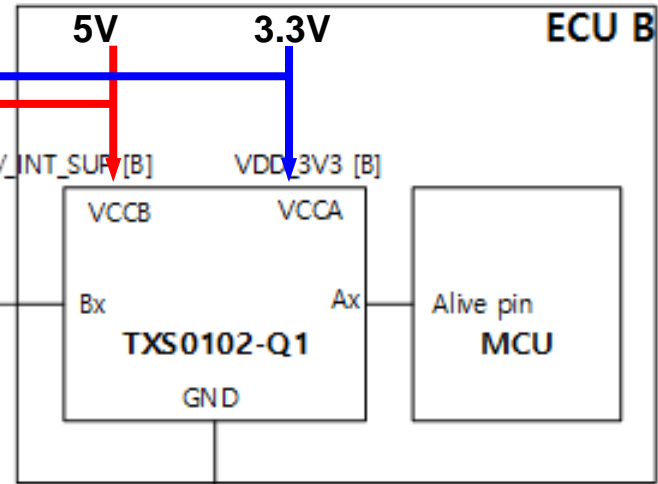

TXS0102-Q1 Spike issue

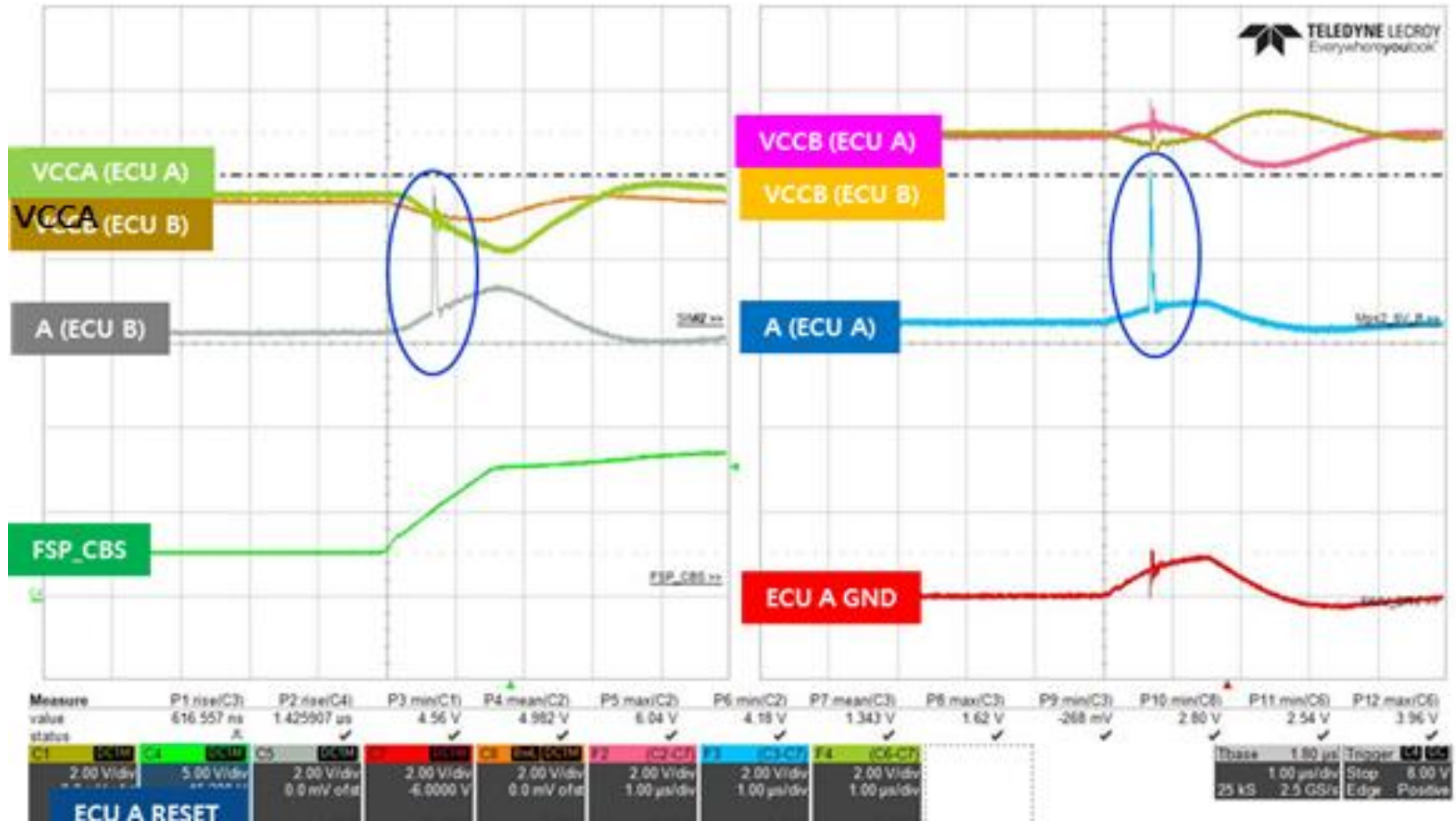

The voltage spikes are occurred on the A pin of TXS0102-Q1 on both ECU-A board and ECU-B board, respectively as above waveform. But these spikes are not occurred when removing each TXS0102-Q1 on the ECU-A and ECU-B boards that is the bypass.

TXS0102-Q1 Noise issue

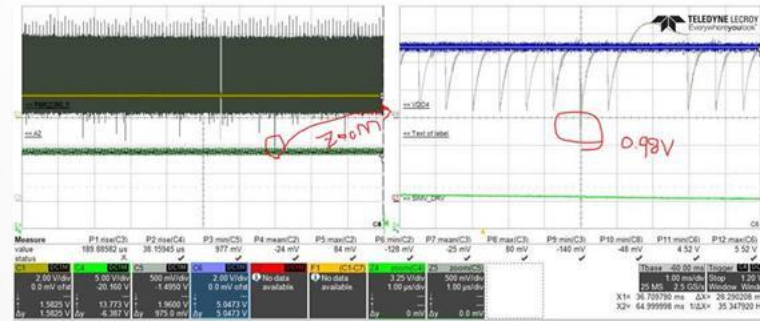
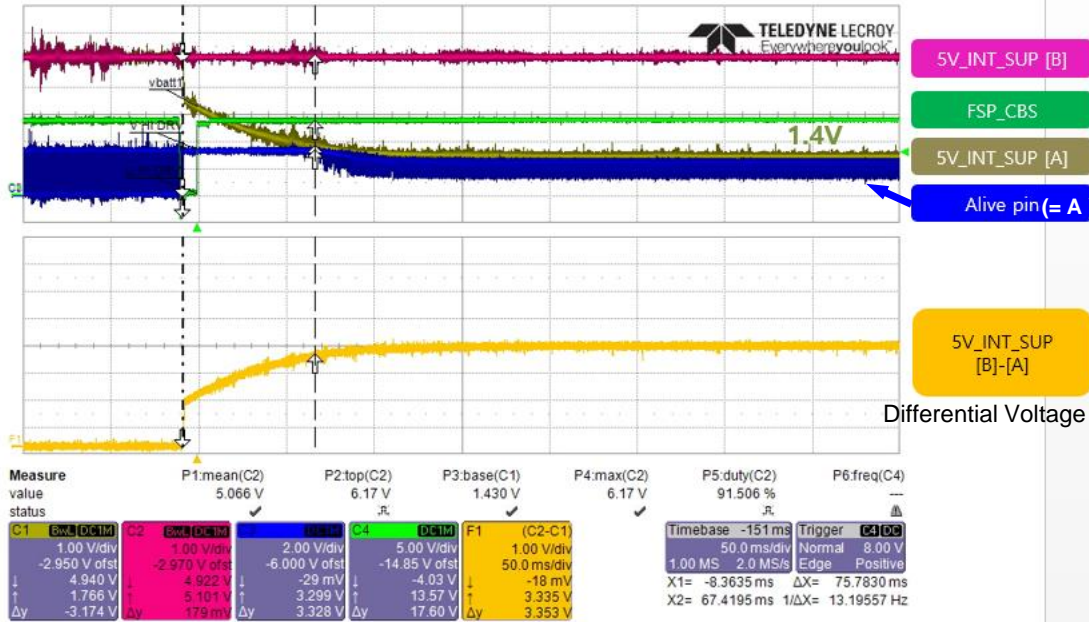

< Zoom : Alive pin (A1) >

The noise are occurred on the A1 pin as waveforms when the voltage differences are around 3.3 ~ 3.9V between 5V_INT_SUP[B] and 5V_INT_SUP[A] for VCCB(B-port supply voltages) of TXS0102-Q1.

