



1. SCOPE

1.1 Scope. This drawing documents the general requirements of a high performance dual 2-input positive OR gate microcircuit, with an operating temperature range of -55°C to +125°C.

1.2 Vendor Item Drawing Administrative Control Number. The manufacturer's PIN is the item of identification. The vendor item drawing establishes an administrative control number for identifying the item on the engineering documentation:

<u>V62/06630</u> Drawing number	-	<u>01</u> Device type (See 1.2.1)	<u>X</u> Case outline (See 1.2.2)	<u>E</u> Lead finish (See 1.2.3)
------------------------------------	---	---	---	--

1.2.1 Device type(s).

<u>Device type</u>	<u>Generic</u>	<u>Circuit function</u>
01	SN74LVC2G32-EP	Dual 2-input positive OR gate

1.2.2 Case outline(s). The case outlines are as specified herein.

<u>Outline letter</u>	<u>Number of pins</u>	<u>JEDEC PUB 95</u>	<u>Package style</u>
X	6	MO-178	Plastic small outline

1.2.3 Lead finishes. The lead finishes are as specified below or other lead finishes as provided by the device manufacturer:

<u>Finish designator</u>	<u>Material</u>
A	Hot solder dip
B	Tin-lead plate
C	Gold plate
D	Palladium
E	Gold flash palladium
Z	Other

1.3 Absolute maximum ratings. 1/

Supply voltage range ( $V_{CC}$ ) .....	-0.5 V to 6.5 V
Input voltage range ( $V_I$ ) .....	-0.5 V to 6.5 V 2/
Voltage range applied to any output in the high impedance or power off state ( $V_O$ ) .....	-0.5 V to 6.5 V 2/
Voltage range applied to any output in the high or low state ( $V_O$ ) .....	-0.5 V to $V_{CC} + 0.5$ V 2/ 3/
Maximum input clamp current ( $I_{IK}$ ) ( $V_I < 0$ ) .....	-50 mA
Maximum output clamp current ( $I_{OK}$ ) ( $V_O < 0$ ) .....	-50 mA
Maximum continuous output current ( $I_O$ ) .....	±50 mA
Maximum continuous current through $V_{CC}$ or GND .....	±100 mA
Maximum package thermal impedance ( $\theta_{JA}$ ) .....	220°C/W 4/
Storage temperature range ( $T_{STG}$ ) .....	-65°C to 150°C

1/ Stresses beyond those listed under "absolute maximum ratings" may cause permanent damage to the device. These are stress ratings only, and functional operation of the device at these or any other conditions beyond those indicated under "recommended operating conditions" is not implied. Exposure to absolute-maximum-rated conditions for extended periods may affect device reliability.

2/ The input negative voltage and output voltage ratings may be exceeded if the input and output current ratings are observed.

3/ This value of  $V_{CC}$  is provided in the recommended operating conditions stable.

4/ The package thermal impedance is calculated in accordance with JESD 51-7.

<b>DEFENSE SUPPLY CENTER, COLUMBUS COLUMBUS, OHIO</b>	<b>SIZE A</b>	<b>CODE IDENT NO. 16236</b>	<b>DWG NO. V62/06630</b>
		REV C	PAGE 2

1.4 Recommended operating conditions. 5/

Supply voltage range ( V <sub>CC</sub> ):	
Operating .....	1.65 V to 5.5 V
Data retention only .....	1.5 V minimum
Minimum high level input voltage	
V <sub>CC</sub> = 1.65 V to 1.95 V .....	0.65 x V <sub>CC</sub>
V <sub>CC</sub> = 2.3 V to 2.7 V .....	1.7 V
V <sub>CC</sub> = 3 V to 3.6 V .....	2.0 V
V <sub>CC</sub> = 4.5 V to 5.5 V .....	0.7 x V <sub>CC</sub>
Maximum high level input voltage	
V <sub>CC</sub> = 1.65 V to 1.95 V .....	0.35 x V <sub>CC</sub>
V <sub>CC</sub> = 2.3 V to 2.7 V .....	0.7 V
V <sub>CC</sub> = 3 V to 3.6 V .....	0.8 V
V <sub>CC</sub> = 4.5 V to 5.5 V .....	0.3 x V <sub>CC</sub>
Input voltage ( V <sub>i</sub> ) .....	0 V to 5.5 V
Output voltage (V <sub>o</sub> ) .....	0 to V <sub>CC</sub>
Maximum high level output current ( I <sub>OH</sub> ):	
V <sub>CC</sub> = 1.65 V .....	-4 mA
V <sub>CC</sub> = 2.3 V .....	-8 mA
V <sub>CC</sub> = 3 V .....	-16 mA
V <sub>CC</sub> = 3 V .....	-24 mA
V <sub>CC</sub> = 4.5 V .....	-32 mA
Maximum low level output current ( I <sub>OL</sub> ):	
V <sub>CC</sub> = 1.65 V .....	4 mA
V <sub>CC</sub> = 2.3 V .....	8 mA
V <sub>CC</sub> = 3 V .....	16 mA
V <sub>CC</sub> = 3 V .....	24 mA
V <sub>CC</sub> = 4.5 V .....	32 mA
Maximum input transition rise or fall rate (Δt/Δv) :	
V <sub>CC</sub> = 1.8 V ±0.15 V, 2.5 V ±V .....	20 ns/V
V <sub>CC</sub> = 3.3 V ±0.3 V .....	10 ns/V
V <sub>CC</sub> = 5.0 V ±0.5 V .....	5 ns/V
Operating free-air temperature range ( T <sub>A</sub> ) .....	-55°C to +125°C

2. APPLICABLE DOCUMENTS

JEDEC – SOLID STATE TECHNOLOGY ASSOCIATION (JEDEC)

- JEP95 – Registered and Standard Outlines for Semiconductor Devices
- JESD51-7 – High Effective Thermal Conductivity Test Board for Leaded Surface Mount Packages

(Copies of these documents are available online at <https://www.jedec.org>).

5/ All unused inputs of the device must be held at V<sub>CC</sub> or GND to ensure proper device operation.

<b>DEFENSE SUPPLY CENTER, COLUMBUS COLUMBUS, OHIO</b>	<b>SIZE A</b>	<b>CODE IDENT NO. 16236</b>	<b>DWG NO. V62/06630</b>
		REV C	PAGE 3

3. REQUIREMENTS

3.1 Marking. Parts shall be permanently and legibly marked with the manufacturer's part number as shown in 6.3 herein and as follows:

- A. Manufacturer's name, CAGE code, or logo
- B. Pin 1 identifier
- C. ESDS identification (optional)

3.2 Unit container. The unit container shall be marked with the manufacturer's part number and with items A and C (if applicable) above.

3.3 Electrical characteristics. The maximum and recommended operating conditions and electrical performance characteristics are as specified in 1.3, 1.4, and table I herein.

3.4 Design, construction, and physical dimension. The design, construction, and physical dimensions are as specified herein.

3.5 Diagrams.

3.5.1 Case outline. The case outline shall be as shown in 1.2.2 and figure 1.

3.5.2 Terminal connections. The terminal connections shall be as shown in figure 2.

3.5.3 Function table. The Function table shall be as shown in figure 3.

3.5.4 Logic diagram. The logic diagram shall be as shown in figure 4.

3.5.5 Load circuit and timing waveforms. The load circuit and timing waveforms shall be as shown in figure 5.

<b>DEFENSE SUPPLY CENTER, COLUMBUS COLUMBUS, OHIO</b>	<b>SIZE A</b>	<b>CODE IDENT NO. 16236</b>	<b>DWG NO. V62/06630</b>
		REV C	PAGE 4

TABLE I. Electrical performance characteristics. 1/

Test		Symbol	Conditions -55°C ≤ T <sub>A</sub> ≤ 125°C unless otherwise specified	V <sub>CC</sub>	Limits		Unit
					Min	Max	
High level output voltage	V <sub>OH</sub>	I <sub>OH</sub> = -100 μA	1.65 V to 4.5 V	V <sub>CC</sub> - 0.1		V	
		I <sub>OH</sub> = -4 mA	2.3 V	1.2			
		I <sub>OH</sub> = -8 mA	3.0 V	1.9			
		I <sub>OH</sub> = -16 mA		2.4			
		I <sub>OH</sub> = -24 mA	4.5 V	2.3			
		I <sub>OH</sub> = -32 mA	5.5 V	3.8			
Low level output voltage	V <sub>OL</sub>	I <sub>OL</sub> = 100 μA	1.65 V to 4.5 V		0.1	V	
		I <sub>OL</sub> = 4 mA	2.3 V		0.45		
		I <sub>OL</sub> = 8 mA	3.0 V		0.3		
		I <sub>OL</sub> = 16 mA		0.4			
		I <sub>OL</sub> = 24 mA	4.5 V	0.55			
		I <sub>OL</sub> = 32 mA	5.5 V	0.55			
Input current	A or B inputs	I <sub>I</sub>	V <sub>I</sub> = 5.5 V or GND	0 to 5.5 V		±5	μA
Off current		I <sub>off</sub>	V <sub>I</sub> or V <sub>O</sub> = 5.5 V	0		±10	μA
Supply current		I <sub>CC</sub>	V <sub>I</sub> = 5.5 V or GND, I <sub>O</sub> = 0,	1.65 V to 5.5V		10	μA
Quiescent supply current		ΔI <sub>CC</sub>	One input at V <sub>CC</sub> - 0.6 V, Other input at V <sub>CC</sub> or GND	3.0 V to 5.5V		500	μA
Input capacitance		C <sub>i</sub>	V <sub>I</sub> = V <sub>CC</sub> or GND, T <sub>A</sub> = 25°C	3.3 V	5 Typ		pF
Propagation time from input A or B to output Y		t <sub>pd</sub>		1.8 V ±0.15 V	2.4	11	ns
				2.5 V ±0.2 V	1	7.5	
				3.3 V ±0.3 V	1	5.8	
				5.0 V ±0.5 V	1	4.7	
Power dissipation capacitance		C <sub>pd</sub>	f = 10 MHz, T <sub>A</sub> = 25°C	1.8 V	17 Typ		pF
				2.5 V	17 Typ		
				3.3 V	17 Typ		
				5.0 V	19 Typ		

1/ Testing and other quality control techniques are used to the extent deemed necessary to assure product performance over the specified temperature range. Product may not necessarily be tested across the full temperature range and all parameters may not necessarily be tested. In the absence of specific parametric testing, product performance is assured by characterization and/or design.

<b>DEFENSE SUPPLY CENTER, COLUMBUS COLUMBUS, OHIO</b>	<b>SIZE A</b>	<b>CODE IDENT NO. 16236</b>	<b>DWG NO. V62/06630</b>
		<b>REV C</b>	<b>PAGE 5</b>

Case X

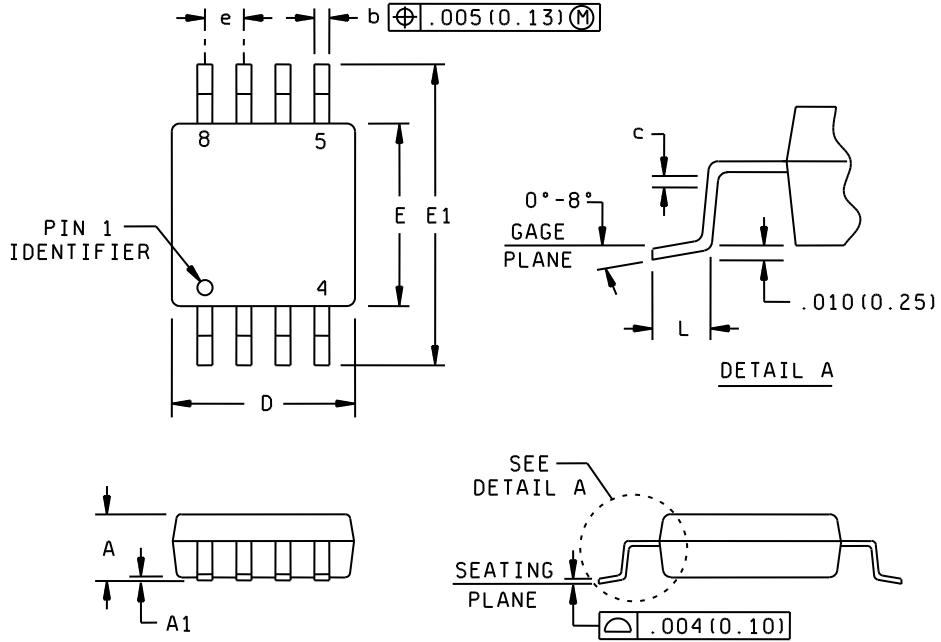

Dimension					
Symbol	Millimeters		Symbol	Millimeters	
	Min	Max		Min	Max
A		1.30	E	2.70	2.90
A1	0.00	0.10	E1	3.75	4.25
b	0.15	0.30	e	0.65 TYP	
c	0.15 NOM		L	0.20	0.60
D	2.75	3.15			

NOTES:

1. This drawing is subject to change without notice.
2. Body dimensions do not include mold flash or protrusion.
3. Falls within JEDEC MO-187 variation DA.

FIGURE 1. Case outline.

DEFENSE SUPPLY CENTER, COLUMBUS COLUMBUS, OHIO	SIZE <b>A</b>	CODE IDENT NO. <b>16236</b>	DWG NO. <b>V62/06630</b>
		REV C	PAGE 6

Case X

Terminal number	Terminal symbol	Terminal number	Terminal symbol
1	1A	5	2A
2	1B	6	2B
3	2Y	7	1Y
4	GND	8	V <sub>cc</sub>

FIGURE 2. Terminal connections.

Inputs		Output Y
A	B	
H	X	H
X	H	H
L	L	L

FIGURE 3. Function table.



FIGURE 4. Logic diagram.

<b>DEFENSE SUPPLY CENTER, COLUMBUS COLUMBUS, OHIO</b>	<b>SIZE A</b>	<b>CODE IDENT NO. 16236</b>	<b>DWG NO. V62/06630</b>
		<b>REV C</b>	<b>PAGE 7</b>

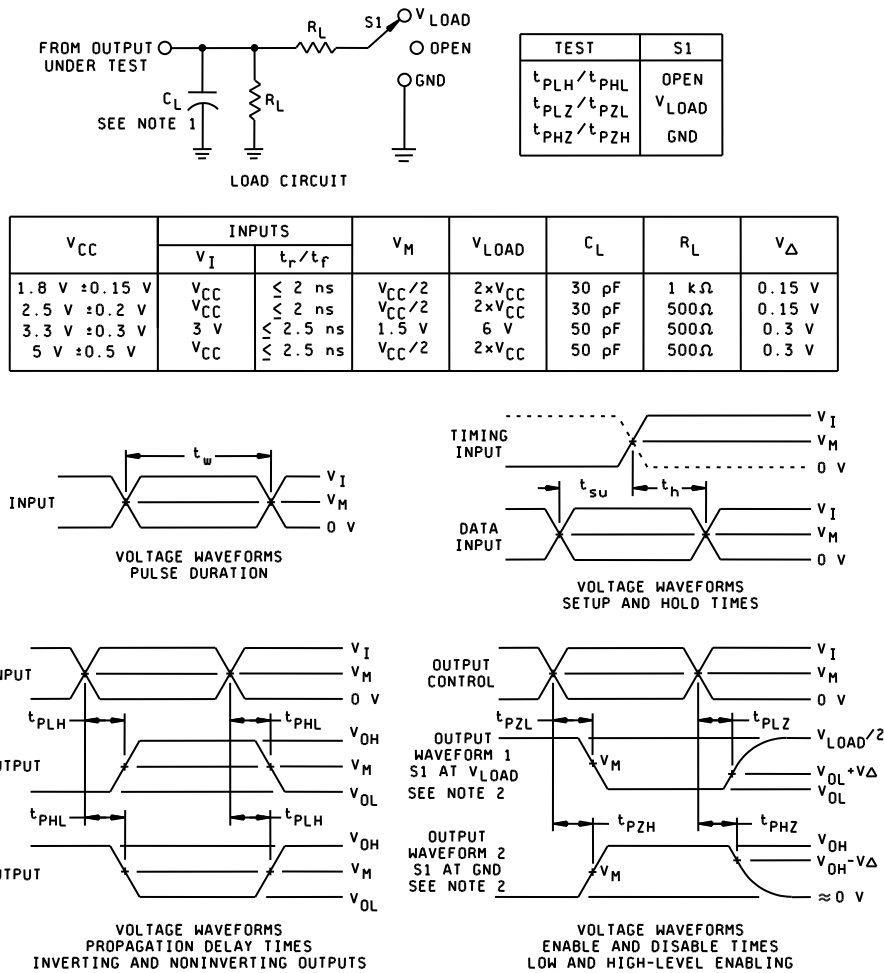

NOTES:

1.  $C_L$  includes probe and jig capacitance.
2. Waveform 1 is for an output with internal conditions such that the output is low except when disabled by the output control. Waveform 2 is for an output with internal conditions such that the output is high except when disabled by the output control.
3. All input pulses are supplied by generators having the following characteristics:  $PRR \leq 10$  MHz,  $Z_O = 50 \Omega$ .
4. The outputs are measured one at a time with one input transition per measurement.
5.  $t_{PLZ}$  and  $t_{PHZ}$  are the same as  $t_{dis}$ .
6.  $t_{PZL}$  and  $t_{PZH}$  are the same as  $t_{en}$ .
7.  $t_{PHL}$  and  $t_{PLH}$  are the same as  $t_{pd}$ .
8. All parameters and waveforms are not applicable to all devices.

FIGURE 5. Load circuit and timing waveforms.

<p align="center"><b>DEFENSE SUPPLY CENTER, COLUMBUS COLUMBUS, OHIO</b></p>	<p align="center">SIZE <b>A</b></p>	<p align="center">CODE IDENT NO. <b>16236</b></p>	<p align="center">DWG NO. <b>V62/06630</b></p>
		<p align="center">REV    C</p>	<p align="center">PAGE    8</p>



4. VERIFICATION

4.1 Product assurance requirements. The manufacturer is responsible for performing all inspection and test requirements as indicated in their internal documentation. Such procedures should include proper handling of electrostatic sensitive devices, classification, packaging, and labeling of moisture sensitive devices, as applicable.

5. PREPARATION FOR DELIVERY

5.1 Packaging. Preservation, packaging, labeling, and marking shall be in accordance with the manufacturer's standard commercial practices for electrostatic discharge sensitive devices.

6. NOTES

6.1 ESDS. Devices are electrostatic discharge sensitive and are classified as ESDS class 1 minimum.

6.2 Configuration control. The data contained herein is based on the salient characteristics of the device manufacturer's data book. The device manufacturer reserves the right to make changes without notice. This drawing will be modified as changes are provided.

6.3 Suggested source(s) of supply. Identification of the suggested source(s) of supply herein is not to be construed as a guarantee of present or continued availability as a source of supply for the item. DLA Land and Maritime maintains an online database of all current sources of supply at <https://landandmaritimeapps.dla.mil/programs/smcr/>.

Vendor item drawing administrative control number <u>1/</u>	Device manufacturer CAGE code	Vendor part number	Top side Marking <u>2/</u>
V62/06630-01XE	01295	SN74LVC2G32MDCUREP	BUE

1/ The vendor item drawing establishes an administrative control number for identifying the item on the engineering documentation.

2/ DCU: The actual top side marking has three additional characters that designate the year, month, and assembly/test site.

CAGE code

01295

Source of supply

Texas Instruments, Inc.  
Semiconductor Group  
8505 Forest lane  
P.O. Box 660199  
Dallas, TX 75243

<b>DEFENSE SUPPLY CENTER, COLUMBUS COLUMBUS, OHIO</b>	<b>SIZE A</b>	<b>CODE IDENT NO. 16236</b>	<b>DWG NO. V62/06630</b>
		REV C	PAGE 9