

# System overview

A system that drives a motor with a remote control.

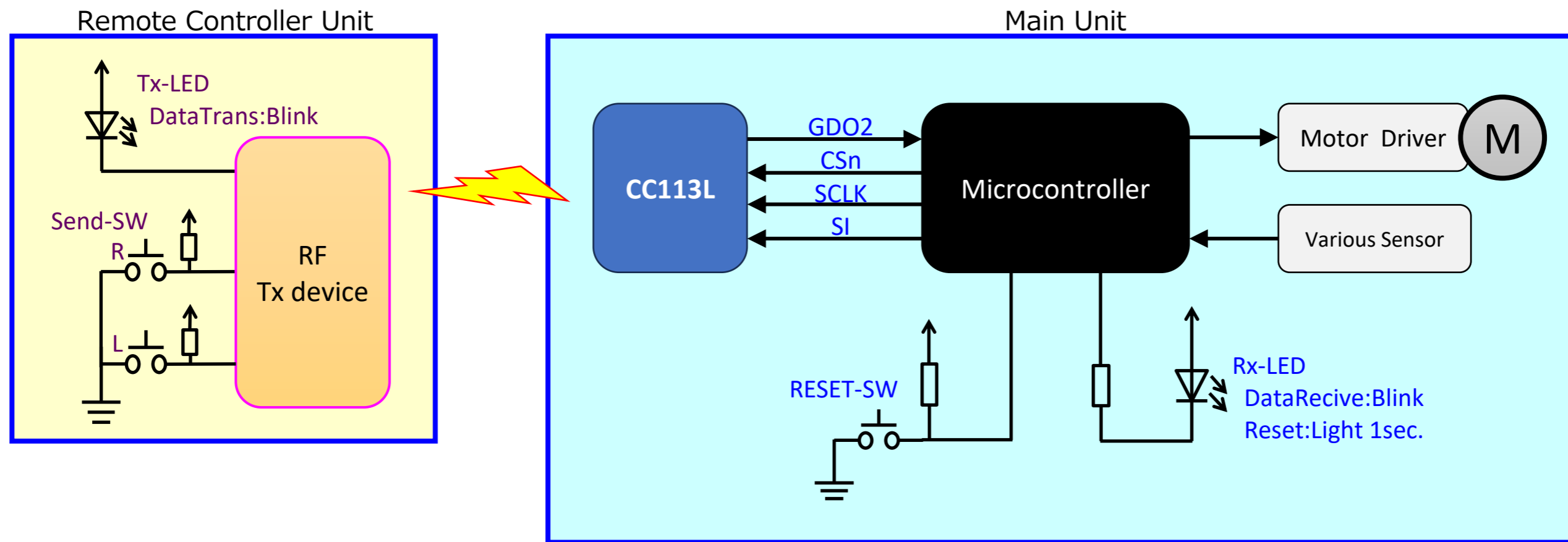

## Sequence

### Normal Conditions

In operation:

1. Press Send-SW.
2. Tx-LED is Blink.
3. Serial data output from GDO2 port.
4. Rx-LED blinking.
5. Motor rotates.

At reset:

1. Press RESET-SW.
2. Rx-LED will light up for 1 second.
3. Normal Conditions.

### Error Conditions

In operation:

1. Press Send-SW.
2. Tx-LED is Blink.
3. Noise output from GDO2 port.
4. Rx-LED is not light.
5. Motor dose not rotates.

At reset:

1. Press RESET-SW.
2. Rx-LED will light up for 1 second.
3. But, Not revive.