

Keep the trace of USSXTIN and USSXTOUT as short as possible. In case one must be longer than the other, keep USSXTIN shorter because USSXTIN Make ground shield open ended without making a loop

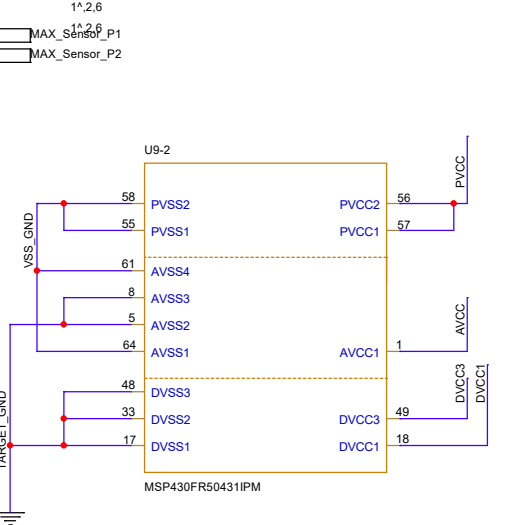

Author	NAME	DATE	
<Author>	<Name>	<Date1>	
DRAWN	<DRAWN>	<Date2>	
CHECKED	<CHECKED>	<Date3>	
Variant	ClipOn	170124	
Size	<Doc>	Document Number	Rev <RevCode>
Date	Sunday, March 03, 2024	Sheet 4	of 9