

[15] xxxxxxxxxxxx
[15] xxxxxxxxxxxx
[15] xxxxxxxxxxxx
[15] xxxxxxxxxxxx
[15] xxxxxxxxxxxx
[15] xxxxxxxxxxxx

[15] xxxxxxxxxxxx
[15] xxxxxxxxxxxx
[15] xxxxxxxxxxxx
[15] xxxxxxxxxxxx
[15] xxxxxxxxxxxx
[15] xxxxxxxxxxxx
[15] xxxxxxxxxxxx

[15] xxxxxxxxxxxx
[15] xxxxxxxxxxxx
[15] xxxxxxxxxxxx
[15] xxxxxxxxxxxx
[15] xxxxxxxxxxxx
[15] xxxxxxxxxxxx
[15] xxxxxxxxxxxx

[15] xxxxxxxxxxxx
[15] xxxxxxxxxxxx
[15] xxxxxxxxxxxx
[15] xxxxxxxxxxxx
[15] xxxxxxxxxxxx
[15] xxxxxxxxxxxx
[15] xxxxxxxxxxxx

[15] xxxxxxxxxxxx
[15] xxxxxxxxxxxx
[15] xxxxxxxxxxxx
[15] xxxxxxxxxxxx
[15] xxxxxxxxxxxx
[15] xxxxxxxxxxxx
[15] xxxxxxxxxxxx

[15] xxxxxxxxxxxx
[15] xxxxxxxxxxxx
[15] xxxxxxxxxxxx
[15] xxxxxxxxxxxx
[15] xxxxxxxxxxxx
[15] xxxxxxxxxxxx
[15] xxxxxxxxxxxx

[15] xxxxxxxxxxxx
[15] xxxxxxxxxxxx
[15] xxxxxxxxxxxx
[15] xxxxxxxxxxxx
[15] xxxxxxxxxxxx
[15] xxxxxxxxxxxx
[15] xxxxxxxxxxxx

[15] xxxxxxxxxxxx
[15] xxxxxxxxxxxx
[15] xxxxxxxxxxxx
[15] xxxxxxxxxxxx
[15] xxxxxxxxxxxx
[15] xxxxxxxxxxxx
[15] xxxxxxxxxxxx

[15] xxxxxxxxxxxx
[15] xxxxxxxxxxxx
[15] xxxxxxxxxxxx
[15] xxxxxxxxxxxx
[15] xxxxxxxxxxxx
[15] xxxxxxxxxxxx
[15] xxxxxxxxxxxx

[15] xxxxxxxxxxxx
[15] xxxxxxxxxxxx
[15] xxxxxxxxxxxx
[15] xxxxxxxxxxxx
[15] xxxxxxxxxxxx
[15] xxxxxxxxxxxx
[15] xxxxxxxxxxxx

[15] xxxxxxxxxxxx
[15] xxxxxxxxxxxx
[15] xxxxxxxxxxxx
[15] xxxxxxxxxxxx
[15] xxxxxxxxxxxx
[15] xxxxxxxxxxxx
[15] xxxxxxxxxxxx

[15] xxxxxxxxxxxx
[15] xxxxxxxxxxxx
[15] xxxxxxxxxxxx
[15] xxxxxxxxxxxx
[15] xxxxxxxxxxxx
[15] xxxxxxxxxxxx
[15] xxxxxxxxxxxx

[15] xxxxxxxxxxxx
[15] xxxxxxxxxxxx
[15] xxxxxxxxxxxx
[15] xxxxxxxxxxxx
[15] xxxxxxxxxxxx
[15] xxxxxxxxxxxx
[15] xxxxxxxxxxxx

[15] xxxxxxxxxxxx
[15] xxxxxxxxxxxx
[15] xxxxxxxxxxxx
[15] xxxxxxxxxxxx
[15] xxxxxxxxxxxx
[15] xxxxxxxxxxxx
[15] xxxxxxxxxxxx

[15] xxxxxxxxxxxx
[15] xxxxxxxxxxxx
[15] xxxxxxxxxxxx
[15] xxxxxxxxxxxx
[15] xxxxxxxxxxxx
[15] xxxxxxxxxxxx
[15] xxxxxxxxxxxx

[15] xxxxxxxxxxxx
[15] xxxxxxxxxxxx
[15] xxxxxxxxxxxx
[15] xxxxxxxxxxxx
[15] xxxxxxxxxxxx
[15] xxxxxxxxxxxx
[15] xxxxxxxxxxxx

[15] xxxxxxxxxxxx
[15] xxxxxxxxxxxx
[15] xxxxxxxxxxxx
[15] xxxxxxxxxxxx
[15] xxxxxxxxxxxx
[15] xxxxxxxxxxxx
[15] xxxxxxxxxxxx

[15] xxxxxxxxxxxx
[15] xxxxxxxxxxxx
[15] xxxxxxxxxxxx
[15] xxxxxxxxxxxx
[15] xxxxxxxxxxxx
[15] xxxxxxxxxxxx
[15] xxxxxxxxxxxx

[15] xxxxxxxxxxxx
[15] xxxxxxxxxxxx
[15] xxxxxxxxxxxx
[15] xxxxxxxxxxxx
[15] xxxxxxxxxxxx
[15] xxxxxxxxxxxx
[15] xxxxxxxxxxxx

[15] xxxxxxxxxxxx
[15] xxxxxxxxxxxx
[15] xxxxxxxxxxxx
[15] xxxxxxxxxxxx
[15] xxxxxxxxxxxx
[15] xxxxxxxxxxxx
[15] xxxxxxxxxxxx

[15] xxxxxxxxxxxx
[15] xxxxxxxxxxxx
[15] xxxxxxxxxxxx
[15] xxxxxxxxxxxx
[15] xxxxxxxxxxxx
[15] xxxxxxxxxxxx
[15] xxxxxxxxxxxx

[15] xxxxxxxxxxxx
[15] xxxxxxxxxxxx
[15] xxxxxxxxxxxx
[15] xxxxxxxxxxxx
[15] xxxxxxxxxxxx
[15] xxxxxxxxxxxx
[15] xxxxxxxxxxxx

**INVERTING AMPLIFIER
GAIN = -7**

**2KHz ANTIALIASING
ANALOG LOW
PASS FILTER
GAIN = 1**

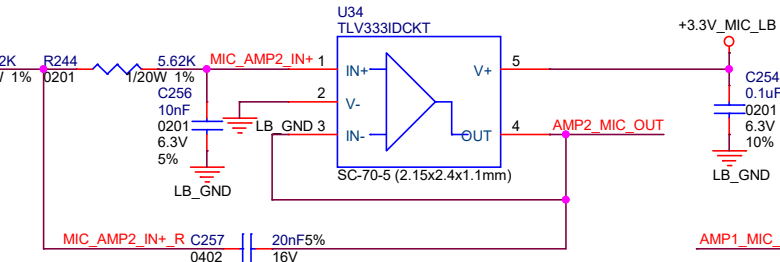
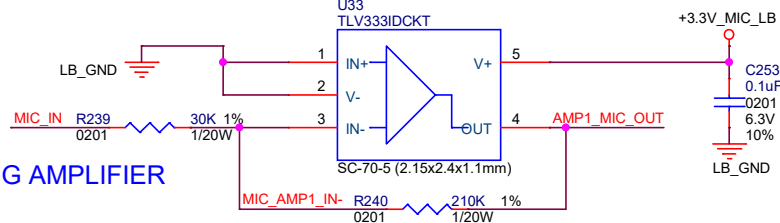

AMP1_MIC_OUT R247 100K 1%
R247 0201
LB_AMP1_MIC_MSP430_ADC [18]

AMP2_MIC_OUT R249 100K 1%
R249 0201
LB_AMP2_MIC_MSP430_ADC [18]

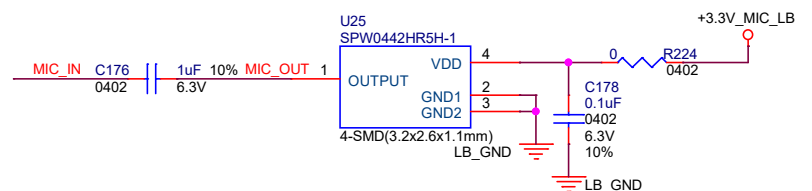
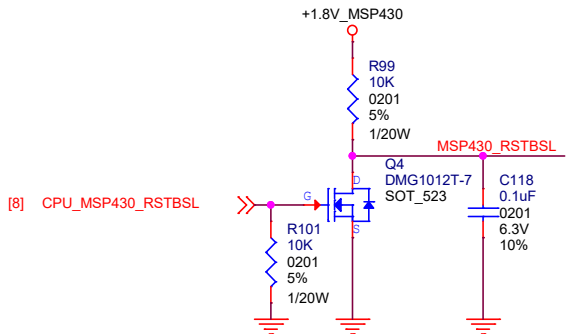
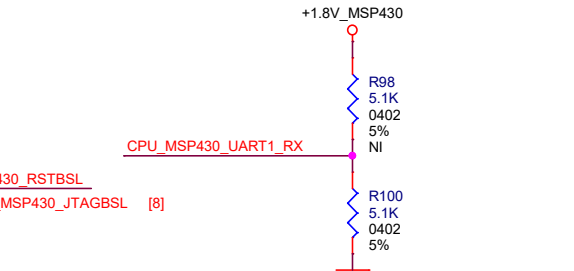
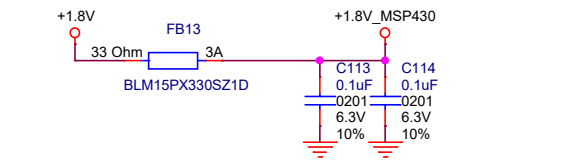

Title <Title>		
Size B	Document Number <Doc>	Rev <RevCod>
Date: Thursday, March 15, 2018	Sheet 1	of 1