

Motor Drive and Control Solutions

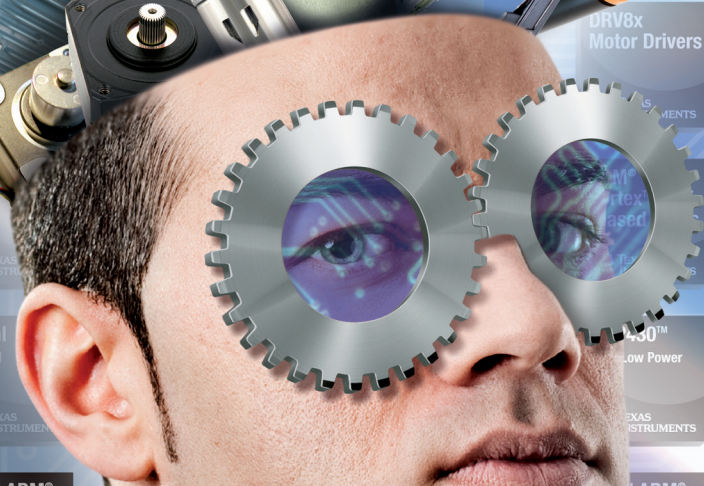
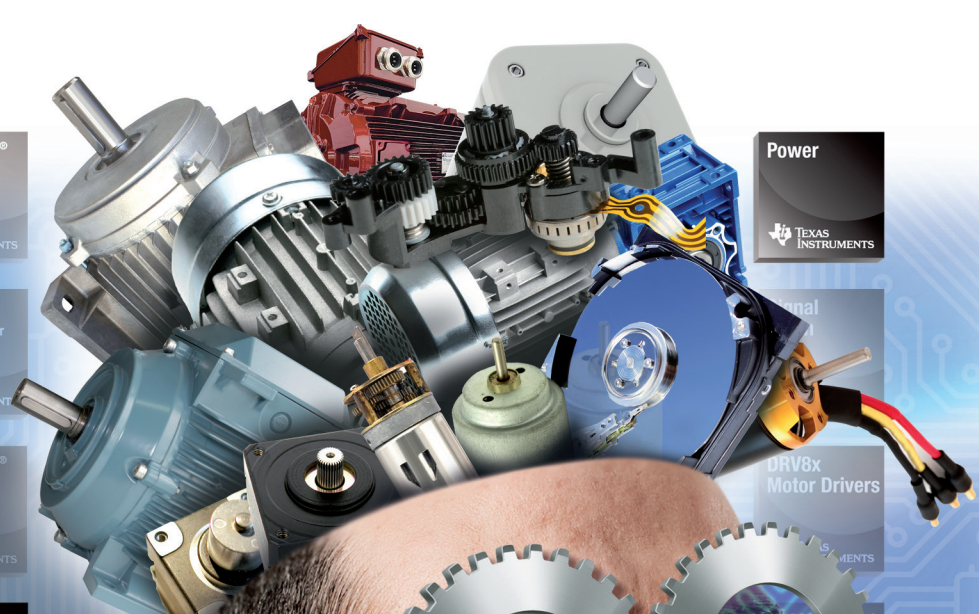
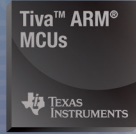
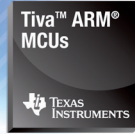

software

system solutions

hardware

Motor Drive and Control Solutions

Table of Contents

Introduction

Texas Instruments (TI) is a global market leader that provides complete motor-drive and control solutions along with broad analog and microcontroller portfolios. TI offers comprehensive tools, software and support to deliver efficient, reliable, cost-effective motor solutions. Customers can get the right products with the right performance to quickly spin motors such as AC induction motors (ACIMs), brushed DC motors, brushless DC (BLDC) motors, permanent-magnet synchronous motors (PMSMs) and stepper motors.

When you want the broadest motor expertise, breadth of selection and comprehensive support, you want TI as your partner for efficient, reliable and cost-effective motor-drive and control solutions.

Motor Control System Functions

Host – Motion profile, logic controller or user interface, often communicating over a standard or proprietary field bus (CAN, serial, and Ethernet such as EtherCAT, Ethernet POWERLINK or EtherNet/IP).

Digital Isolation – Protection and level shifting between different voltage levels.

Controller – Generates the proper switching patterns to control the motor's motion based on feedback and motion profile information from the host.

Gate Drivers – Generate the necessary voltage and current required to accurately and efficiently drive the MOSFETS or IGBTs.

Power Stage – IGBTs or MOSFETS

Sensing – Analog circuitry which processes/conditions the feedback from the motor to control torque, speed or position.

Motor Drive and Control Solutions

- 2 Introduction
- 2 Motor Control System Functions
- 3 InstaSPIN™-FOC
- 3 InstaSPIN™-MOTION

Complete TI Motor-Drive Solutions

- 4 Stepper Motors
- 4 Brushed DC Motors
- 5 Brushless DC (BLDC) Motors
- 5 Permanent Magnet Synchronous Motors (PMSMs)
- 6 AC Induction Motors (ACIMs)
- 6 Third-Party Network Developers

DRV8x Integrated Motor Drivers

- 7 Introduction
- 7 Permanent Magnet Synchronous Motors (PMSMs)

Signal Chain Solutions

- 8 Low Offset is the TI Advantage
- 8 Industrial Communications (Interface)
- 9 Delta-Sigma Modulators in Current Measurement and Motor Control
- 9 20MHz, Second-Order, Isolated Delta-Sigma Modulators for Current-Shunt Measurement
- 10 Simultaneous-Sampling ADCs for High-End Motor Drives
- 10 ADCs for Motor Control
- 10 Industrial Ethernet
- 10 LDO Linear Regulators
- 11 Digital Isolators
- 11 SO5500 Family Isolated Gate Drivers

Microcontrollers for Motor Control

- 12 C2000™ 32-Bit Real-Time Microcontrollers
- 12 C2000™ Device Features
- 13 controlSUITE™ Digital Motor Control (DMC) Library
- 14-15 Tiva™ C Series Kits
- 16 Hercules™ TMS570 32-Bit ARM® Cortex™-R4 Safety Microcontrollers

Special Purpose Processors for Motion Control

- 17 Trajectory controllers

Integrated Fan Motor Drivers

- 18 The TI Advantage – Maximum Integration
- 18 Integrated Fan Motor Drivers

Selection Guides for Analog Motor Solutions

- 19 Stepper Motor Drivers
- 20 Brushed and Brushless DC Motor Drivers
- 21 CAN Transceivers (CANopen systems compliant)
- 21 Digital Isolators
- 21 IGBT Gate Drivers
- 23 Power Management
- 23 Recommended Products for Industrial Motor Drive and Control

NexFET Power MOSFET

- 25 Single N-Channel
- 25 Dual N-Channel

Pre-Driver – Gate drivers, sensing and protection circuitry integrated into a single device or package that may also include control logic.

Integrated Motor Driver – Gate driver, FETs and protection circuitry integrated into a single device or package that may also include control logic and sensing circuitry.

Learn more at:
www.ti.com/motor

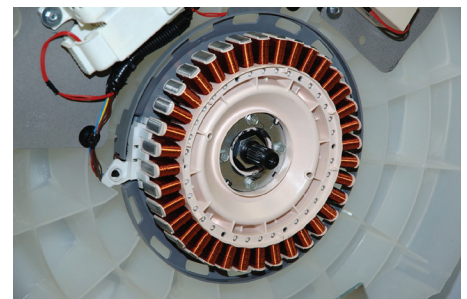

Motor Drive and Control Solutions

Breakthrough motor control technology

InstaSPIN™ software solutions make designing motor control applications easier and faster. Identify, tune and fully control any type of three-phase, variable speed, sensorless, synchronous or asynchronous motor control system in just minutes.

InstaSPIN™-FOC

TI's InstaSPIN-FOC software solution takes advantage of the FAST™ premium software sensor for rotor flux measurement and provides motor identification, automatic current control tuning and sensorless feedback in a field-oriented control (FOC) torque controller and speeds deployment of efficient, sensorless, variable load three-phase motor solutions.

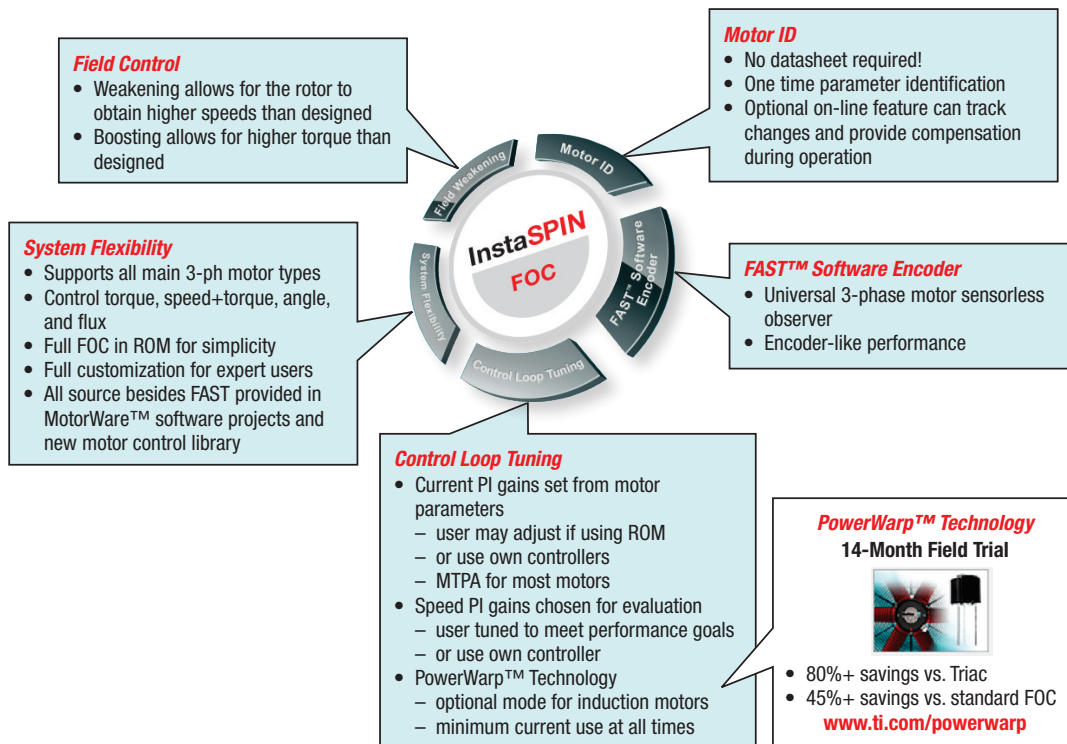

InstaSPIN™-MOTION

Built upon TI's InstaSPIN-FOC technology, InstaSPIN-MOTION software powered by SpinTAC™ technology provides accurate speed control with minimal disturbance.

IDENTIFY – Ensure optimum tracking and disturbance rejection, working with the real inertia of the system.

CONTROL – Minimize effort and reduce complexity with single coefficient tuning. Rapidly test and tune velocity control from soft to stiff response, defining a controller gain that typically works across the entire variable speed and load range of an application. Actively estimate and cancel system disturbances in real time, providing maximum performance.

MOVE – Produce an automatically optimized motion profile based on start velocity, target velocity and system limitations for acceleration, jerk and motion trajectory type.

PLAN – Quickly build various states of motion (speed A to speed B) and tie them together with state-based logic



Learn more at: www.ti.com/InstaSPIN

Complete TI Motor-Drive Solutions

Stepper Motors

Steppers are a cost-effective solution for open-loop position-control applications such as printers, scanners, home/office appliances and scientific or medical equipment.

DRV8711EVM - \$99

- DRV8711-based motor controller capable of up to 10A at 52V
- Excellent thermal performance with external NextFET power MOSFETs
- Stepper motor included and the GUI defaults to optimum settings matched to the included motor.
- Configurable for dual DC motor control
- Open source: BOM, Schematics, Gerbers

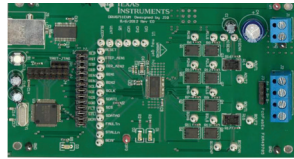

DRV8412-C2-KIT - \$199

- 52V, 3.5A 3-phase motor driver stage
- Quadrature encoder interface
- Piccolo F28035 microcontroller control
- Includes two brushed DC and one stepper motor

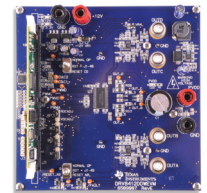

DRV8829EVM - \$149

- Two 5-A H-bridge motor drivers
- Phase/enable control interface and low component count
- Easy-to-use GUI for quick setup with most motors
- Open source: BOM, schematics, Gerbers

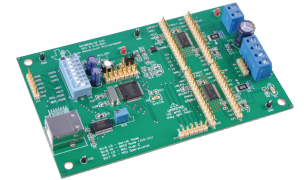

DRV8818EVM - \$99

- DRV8818-based motor driver capable of 2.5 A at 35 V
- Updated user interface for acceleration and deceleration profiles
- Open source: BOM, schematics, Gerbers

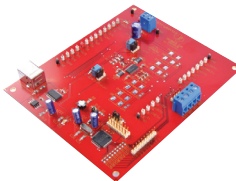

Brushed DC Motors

DC motors are used when simple control and cost effectiveness are required in applications such as toys and small consumer appliances.

DRV8839EVM - \$25

- Low-voltage DRV8839 evaluation module spins dual brushed motors, operates from 1.8V to 11V, and delivers up to 2x 1.8A
- On-board speed and direction controls; Micro-USB connection for easy evaluation / power up
- Open source: BOM, Schematics, Gerbers

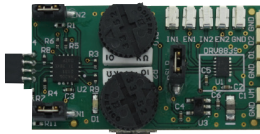

DRV8801EVM - \$99

- DRV8801-based motor driver capable of 2.8A peak at 36 V
- Easy-to-use GUI for quick setup with most motors
- Open source: BOM, schematics, Gerbers

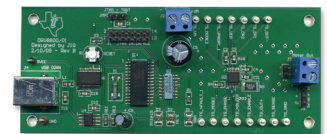

Easy-to-Use Graphical User Interface (GUI)

- Stand-alone GUI requires no IDE
- Immediate verification of motor-control operation
- Configurable capabilities
- Sliders and input fields
- Real-time graphing of key variables
- Free with most motor-control kits

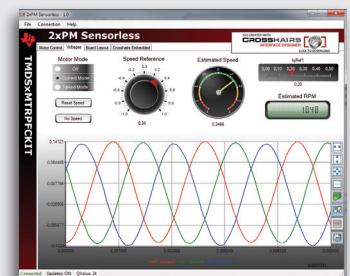

DRV8412-C2-KIT - \$199

- 52V, 3.5A 3-phase motor driver stage
- Quadrature encoder interface
- Piccolo F28035 microcontroller control
- Includes two brushed DC and one stepper motor
-

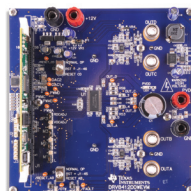

RDK-BDC24 - \$219

- Controls brushed 24-V DC motors with up to 40 A continuous
- Three options for open-loop voltage control and two options for closed-loop, speed, position or current control
- CAN and RS-232 communication



Complete TI Motor-Drive Solutions

Brushless DC (BLDC) Motors

BLDC motors are widely used in speed-control applications where reliability and ruggedness are required, such as in fans, pumps and compressors.

TMDSHVMTRPFCKIT - \$599

TMDSHVMTRINSPIN - \$699

- Piccolo™ controlCARD-based hardware
- 350-V, 1.5-kW three-phase inverter
- 700-W bypassable PFC (DC bus) front end
- Isolated JTAG, UART, SPI, and CAN
- Free Code Composer Studio™ development environment
- Software support through controlSUITE™ or MotorWare™
- Sensors: Hall, Encoder, Software (sensorless)
- Control: Torque, Speed, Position, PFC



DRV8312-Based Kits – \$299 Each

- 50V, 3.5A 3-phase motor driver stage
- NEMA17 BLDC/PMSM 55W motor
- Spin your own motor instantly with InstaSPIN™-BLDC, InstaSPIN-FOC and InstaSPIN-MOTION software
- Hall & Quadrature encoder interfaces
- Isolated SPI and CAN interfaces



DRV8301/2-Based Kits – \$299 to \$499 Each

- 60V, 60A 3-phase motor driver stage
- NO motor included
- Spin your own motor instantly with InstaSPIN-BLDC, InstaSPIN-FOC and InstaSPIN-MOTION software
- Hall & Quadrature encoder interfaces
- Isolated SPI and CAN interfaces
- Includes Piccolo F28035, Hercules™ RM48 or TMS570LS31 controlCARD and can accept many TI MCU-based controlCARDS



Learn more about the DRV8312-based kits and DRV8301/2-based kits at:

DRV8312-C2-KIT: www.ti.com/tool/drv8312-c2-kit

DRV8312-69M-KIT: www.ti.com/tool/drv8312-69m-kit

DRV8301-HC-C2-KIT: www.ti.com/tool/drv8301-hc-c2-kit

DRV8302-HC-C2-KIT: www.ti.com/tool/drv8302-hc-c2-kit

DRV8312-C2-KIT: www.ti.com/tool/drv8312-c2-kit

DRV8301-69M-KIT: www.ti.com/tool/drv8301-69m-kit

DRV8301-RM48-KIT: www.ti.com/tool/drv8301-rm48-kit

DRV8301-LS31-KIT: www.ti.com/tool/drv8301-ls31-kit

Permanent Magnet Synchronous Motors (PMSMs)

PMSMs are used in applications requiring precise control and low torque ripple, such as robotics, servo systems and electric power steering.

DRV8312-Based Kits – \$299 Each

- 50V, 3.5A 3-phase motor driver stage
- NEMA17 BLDC/PMSM 55W motor
- Spin your own motor instantly with InstaSPIN™-BLDC, InstaSPIN-FOC and InstaSPIN-MOTION software
- Hall & Quadrature encoder interfaces
- Isolated SPI and CAN interfaces



TMDSHVMTRPFCKIT - \$599

TMDSHVMTRINSPIN - \$699

- Piccolo(tm) controlCARD-based hardware
- 350-V, 1.5-kW three-phase inverter
- 700-W bypassable PFC (DC bus) front end



- Isolated JTAG, UART, SPI, and CAN
- Free Code Composer Studio™ development environment
- Software support through controlSUITE™ or MotorWare™
- Sensors: Hall, Encoder, Software (sensorless)
- Control: Torque, Speed, Position, PFC

DRV8301/2-Based Kits – \$299 to \$499 Each

- 60V, 60A 3-phase motor driver stage
- NO motor included
- Spin your own motor instantly with InstaSPIN™-BLDC, InstaSPIN-FOC and InstaSPIN-MOTION software
- Hall & Quadrature encoder interfaces
- Isolated SPI and CAN interfaces
- Includes Piccolo F28035, Hercules™ RM48 or TMS570LS31 controlCARD and can accept many TI MCU-based controlCARDS



Complete TI Motor-Drive Solutions

AC Induction Motors (ACIMs)

The ACIM is the industrial “muscle motor” that enabled the industrial revolution. This rugged motor is used in a vast array of applications from home appliances to high-horse-power factory automation.

TMDSHVMTRPFCKIT - \$599

TMDSHVMTRINSPIN - \$699

- Piccolo™ controlCARD-based hardware
- 350-V, 1.5-kW three-phase inverter
- 700-W bypassable PFC (DC bus) front end

- Isolated JTAG, UART, SPI, and CAN
- Free Code Composer Studio™ development environment
- Software support through controlSUITE™ or MotorWare™
- Sensors: Hall, Encoder, Software (sensorless)
- Control: Torque, Speed, Position, PFC



Third-Party Network Developers

MathWorks Model-Based Design

Target for C2000™ Microcontrollers

Model-based design integrates MATLAB® and Simulink® with TI's Code Composer Studio™ IDE and C2000™ microcontrollers.

Key Features

- Generates documented, readable and editable C code in Code Composer Studio IDE project format
- Automates the testing and execution of Simulink models
- Enables the real-time evaluation of system designs on TI motor kits
- Provides block-level access to on-chip peripherals
- Provides block-level access to the TI IQMath library for simulation and code generation

Learn more at: www.mathworks.com/c2000

VisSim/Embedded Controls Developer™

VisSim/Embedded Controls Developer is a visual development environment for the rapid prototyping and development of motion-control systems.

Key Features

- VisSim/Motion block set that includes pre-built motor, amplifier, sensor, encoder, dynamic load and closed-loop PID models
- DMC block set includes all of the TI DMC library in block form
- Peripheral blocks generate code for C2000 and soon other TI MCUs
- Automatic C-code generation of production-quality fixed-point code
- Real-time visualization while code executes
- Code Composer Studio IDE plug-in for automatic project creation

Learn more at: www.vissim.com/c2000

TI Motor Design Network Developers

Third Party	Website	Service
D3 Engineering	www.d3engineering.com	Design services, consulting, algorithms, The MathWorks
Drivetech	www.drivetechinc.com	Design services, consulting, DMC expertise
Pentad Design	www.pentaddesign.com	Design services, DPS and CLA expertise
Powersim	www.powersimtech.com	Power electronics simulation and C2000 auto code generation
Simma Software	www.simmasoftware.com	Network protocol software
The MathWorks	www.mathworks.com	Embedded target, auto code generation
Visual Solutions	www.vissim.com	Rapid prototyper: Visual application development

DRV8x Integrated Motor Drivers

The DRV8x family of integrated motor drivers enables customers to quickly and easily spin their motors. Integrated drivers have higher performance, better protection, and require less board space than traditional discrete solutions. Furthermore, integrated drivers do not require discrete drive-stage design experience, which greatly simplifies and speeds the design process.

The TI Advantage

Quicker Time to Spin

With an integrated drive stage, current sensing, on-chip control logic, simple

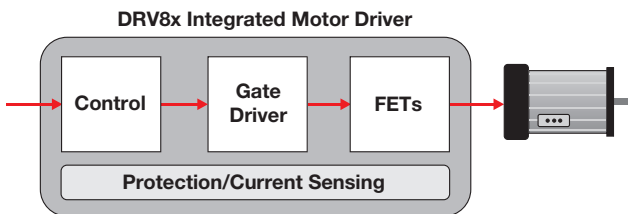

control interfaces, easy-to-use EVMs and design-in documentation, customers can quickly get their motors up and spinning.

Robust, Reliable and Fully Protected

All of TI's motor drivers include fast-acting protection against short circuits, thermal overload, undervoltage and shoot-through. When a fault condition is detected, the H-Bridge is quickly shut down to protect the motor and driver IC.

The Right Part for Each Application

TI has a broad portfolio of motor drivers with different levels of integration, multiple control of interfaces and a wide range of power ratings. The DRV8x family includes both drivers and pre-drivers that support voltage ranges from 1.8 to 60V and load current up to 60A, capable of driving various types of motors and other inductive loads, such as solenoids and relays.

Featured Solenoid Drivers (No catch / freewheel diodes needed)

DriverType	Device	Voltage	Description
Low-Voltage Drivers	DRV8839	1.8 to 11 V	1.8 to 11V
Dual Drivers	DRV8412	0 to 52 V	2 x 6A driver
	DRV8432	0 to 52 V	2 x 14A driver w/ heatsink
	DRV8844	8 to 60 V	2 x 14A driver w/ heatsink
Triple Drivers	DRV8312	0 to 52 V	3 x 3.5A driver
	DRV8313	8 to 60 V	3 x 1.75A driver w/ on-chip LDO
	DRV8332	0 to 52 V	3 x 8A driver w/ heatsink
Quad Drivers	DRV8412	0 to 52 V	4 x 3A driver
	DRV8432	0 to 52 V	4 x 7A driver w/ heatsink
	DRV8803	8.2 to 60 V	4 x 1A driver w/ open-load detect
	DRV8804	8.2 to 60 V	4 x 1A
	DRV8806	8.2 to 40 V	4 x 1A
	DRV8844	8 to 60 V	4 x 1.75A driver w/ on-chip LDO

For more information visit www.ti.com/drv8x

Permanent Magnet Synchronous Motors (PMSMs)

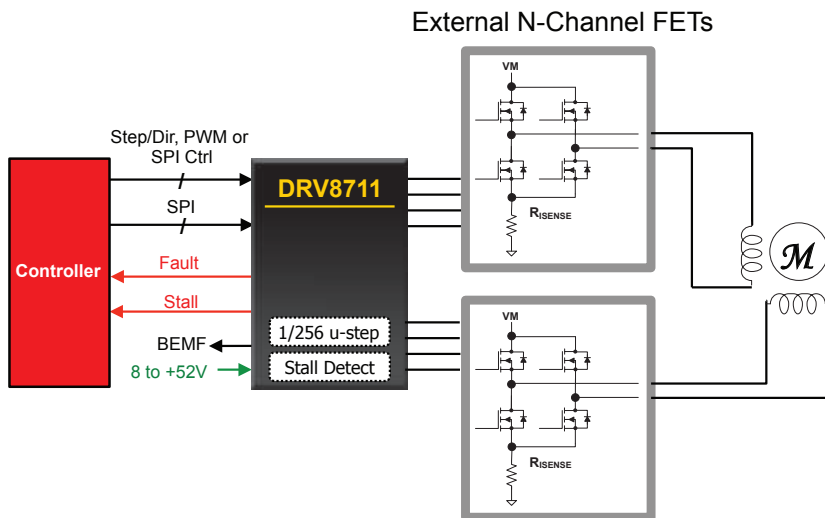

Key Features

- External N-channel MOSFETs
- Adjustable gate-driver parameters
- Advanced highly configurable current regulation and on-chip micro-stepping indexer
- Stall detect with optional BEMF output
- Register based SPI management interface
- Integrated protection & diagnosis

Benefits

- External FETs yields excellent thermal performance, and N-channel FETs on high-side saves system cost
- Tune gate driver performance to application needs
- Ultra-smooth motion profile
- MCU is notified and can take corrective action on a stall event either via internal stall detect or by processing the optional BEMF output
- Simple management interface and advanced protection & diagnosis reduces design complexity and enables higher system reliability

Signal Chain Solutions

Current-Sense Amplifiers

Low Offset is the TI Advantage

Offset and offset-drift performance are factors that determine the full-scale input voltage to the current-sense amplifier and, subsequently, the size of the shunt resistor. Lower offset allows for smaller shunt resistors and results in less voltage drop and power loss.

To avoid errors introduced by external gain resistors, all TI current-sense amplifiers have gain set internally through TI's precision manufacturing processes. Total component count and board space are reduced as well. In addition to the standard configuration of current-sense amplifiers, TI has a

line of digital-output current-sense devices. These devices make isolation easy by limiting the interface to two digital lines, which frees embedded data converters for other system activities.

High Precision for Large Common-Mode Current Measurements

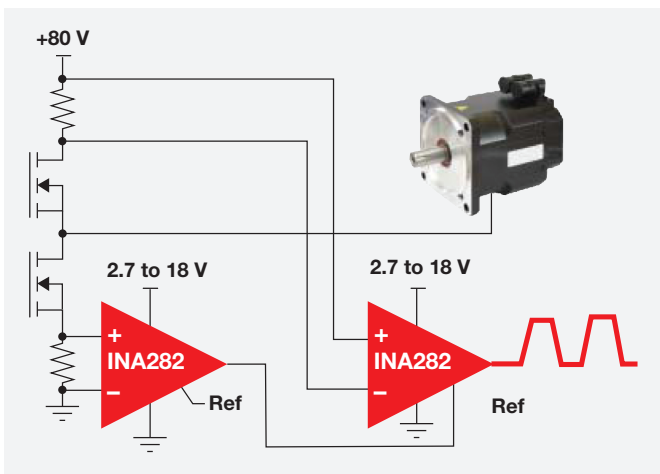

Wide Common-Mode Current-Sense Amplifiers

Device	CMR	Offset	Offset Drift	Bidirectional
INA282	-14 to 80 V	70 μ V	0.5 μ V/ $^{\circ}$ C	Yes
INA138/INA139	2.7 to 36 V	1 mV	1 μ V/ $^{\circ}$ C	No
INA168/INA169	2.7 to 60 V	1 mV	1 μ V/ $^{\circ}$ C	No
INA170	2.7 to 60 V	1 mV	1 μ V/ $^{\circ}$ C	Yes
INA193-INA198	-16 to 80 V	2 mV	2.5 μ V/ $^{\circ}$ C	No
INA149	-275 to +275 V	1.1 mV	3 μ V/ $^{\circ}$ C	Yes
LMP8640HV	-2 to 76 V	1.16 mV	2.6 μ V/ $^{\circ}$ C	No
LMP8645HV	-2 to 76 V	1.7 mV	7 μ V/ $^{\circ}$ C	No
LMP8601	-22 to 60 V	1 mV	10 μ V/ $^{\circ}$ C	Yes
LMP8603	-22 to 60 V	1 mV	10 μ V/ $^{\circ}$ C	Yes

Industrial Communications (Interface)

RS-485/RS-422

- Broad portfolio
- Improved speed, performance and robustness

Speed

- Speeds of up to 50 Mbps

Functionality

- Lower unit load: Up to 256 devices on bus
- 3.3-V supply: No need for extra voltage regulators
- True fail-safe: No need for external biasing resistors
- Slow-rate control reduces EMI
- Receiver equalization enables long cable transmission

Robustness

- Best-in-class ESD protection: Improved reliability
- 400-W transient voltage protection: No need for external components
- Extended common mode: Extends transmission distance

CAN

- Broad portfolio of standard industry upgrades and TI-unique CAN devices
- 5-V CAN transceiver offers the highest ESD protection in the industry: 14 kV

Second-Generation 3.3-V CAN Transceivers

- Lowest power and \pm 36-V protection
- Low-power standby with bus wake-up
- 5- μ A standby power

Isolated Interface

- Integrated interface with isolation
- Uses TI's new differential capacitive technology
- High performance, superior to optical and magnetic isolation
- Integrated design saves board space and simplifies board design

PROFIBUS

- Certified PROFIBUS solution
- PROFIBUS transceiver with isolation

Industrial Ethernet

- Broad portfolio of Ethernet transceivers
- Support for standards such as EtherCAT, Ethernet POWERLINK, EtherNet/IP and more

Signal Chain Solutions

Discrete Analog-to-Digital Converters (ADCs)

Delta-Sigma Modulators in Current Measurement and Motor Control

TI's portfolio of delta-sigma modulators offers both isolated and non-isolated modulators enabling both direct measurement of current through shunt resistors and indirect measurement with Hall or magnetic sensors. The AMC1210 provides a quad-programmable digital filter enabling a seamless interface to the modulators, including a fast over-current detection path. Additionally, the AMC1210 provides PWM excitation for resolvers to enable an analog front-end solution for motor control.

Analog Front End Solution for Motor Control

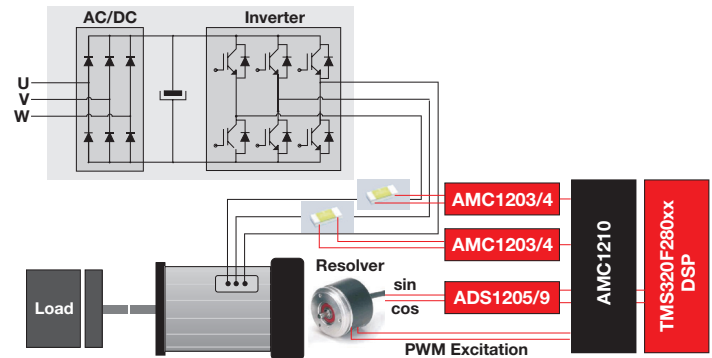

20MHz, Second-Order, Isolated Delta-Sigma Modulators for Current-Shunt Measurement

AMC1204/AMC1204B

The AMC1204 and AMC1204B are 1-bit digital output, isolated delta-sigma ($\Delta\Sigma$) modulators that can be clocked at up to 20MHz and provide a single-chip solution for measuring the small signal of a shunt resistor across an isolated barrier. The modulator output is isolated by a silicon dioxide (SiO_2) barrier that is highly resistant to magnetic interference and is certified to provide basic galvanic isolation of up to 4000VPEAK (AMC1204) and 4250VPEAK (AMC1204B) according to UL1577, IEC60747-5-2, and CSA standards or specifications.

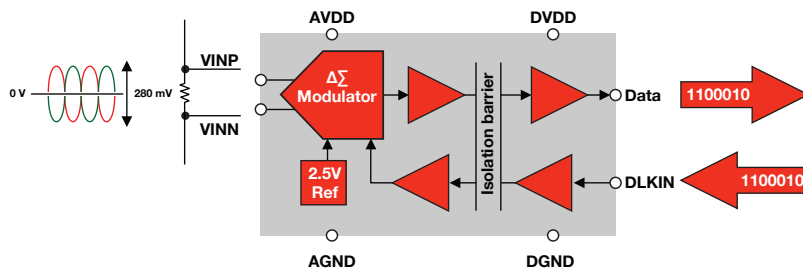

Key Features

- $\pm 250\text{mV}$ Input Voltage Range
Optimized for Shunt Resistors
- External Clock Input Enables Synchronization of Multiple Devices
- Certified Digital Isolation:
 - CSA, IEC60747-5-2, and UL1577 Approved
 - Working Voltage: 1200VPEAK
 - Transient Immunity: $15\text{kV}/\mu\text{s}$
- Outstanding AC Performance:
 - SNR: 84dB (min), THD: -80dB (max)
- Excellent DC Precision:
 - INL: $\pm 8\text{LSB}$ (max), Gain Error: $\pm 2\%$ (max)

Modulators for Current Measurement Applications

Device	Description	Input Voltage Range (mV)	Isolation Rating (Vpeak)	Min Transient Immunity (kV/uS)	Supply Voltage (V)	Hirel Avail.	Package	Price
Isolated Delta-Sigma Modulator								
AMC1204	Isolated 20 MHz $\Delta\Sigma$ Modulator	± 280	4000	15	3.3, 5	N	SOIC-16	3.45
AMC1204B	Isolated 20 MHz $\Delta\Sigma$ Modulator	± 280	4250	15	3.3, 5	N	SOIC-16	3.45
AMC1203	Isolated 10 MHz $\Delta\Sigma$ Modulator	± 280	4000	15	5	N	SOP-8, SOIC-16	3.35
Isolated Amplifier								
AMC1200	Isolated Amplifier with G=8	± 250	4000	10	3.3, 5	N	SOP-8	2.20
AMC1200B	Isolated Amplifier with G=8	± 250	4250	10	3.3, 5	N	SOP-8	2.20
Non-Isolated Delta-Sigma Modulator								
ADS1203	10 MHz $\Delta\Sigma$ Modulator	± 250	N/A	N/A	5	N	TSSOP-8, QFN-16	2.85
ADS1204	4-ch, 10 MHz $\Delta\Sigma$ Modulator	± 2000	N/A	N/A	5	N	QFN-32	6.75
ADS1205	2-ch, 10 MHz $\Delta\Sigma$ Modulator	± 2000	N/A	N/A	5	N	QFN-24	4.95
ADS1208	10 MHz $\Delta\Sigma$ Modulator, with Excitation for Hall Elements	± 100	N/A	N/A	5	N	TSSOP-16	3.15
ADS1209	2-ch, 10 MHz $\Delta\Sigma$ Modulator	± 2300	N/A	N/A	5	N	TSSOP-24	4.5
Digital Filter								
AMC1210	Quad Digital Filter for 2nd-Order $\Delta\Sigma$ Modulator	—	—	—	—	—	—	1.34

*Suggested resale price in U.S. dollars in quantities of 1,000.

New products are listed in **bold red**.

Signal Chain Solutions

Discrete Analog-to-Digital Converters (ADCs)

Simultaneous-Sampling ADCs for High-End Motor Drives

Offering up to eight simultaneously sampled channels, up to 3-MSPS sampling rate, dual independently controlled internal references, small packages, and extended specified temperature range, TI's portfolio of high-performance ADCs are designed to meet the needs of the most demanding high-precision motor-drive applications.

ADCs for Motor Control

Device	Res. (Bits)	Max Sample Rate (kSPS)	No. of input channels	Interface	Input voltage range	V _{REF}	Power (mW)	Evaluation tools	package	Price*
ADS8528/48/68	12/14/16	650/600/510	8 SE	SPI/parallel	±12 V	Int/Ext	335	ADS8568EVM-PDK	LQFP-64, VQFN-64	3.50/6.00/ 9.00
ADS8558/57/56	12/14/16	730/670/670	6 SE	SPI/parallel	±12 V	Int/Ext	262.2/253.2/251.7	ADS8556EVM	LQFP-64	8.95/10.95/ 12.95
ADS7223/7263/8363	12/14/16	1000	8 SE/4 Diff	SPI	±2.5 V	Int/Ext	47.2	ADS8363EVM	QFN-32	3.95/6.95/9.95
ADS7945/46	14	2000	2 Diff/2 P. Diff	SPI	0 - 5.5 V	Ext	10.5	ADS7945EVM-PDK	WQFN-16	3.95/3.80
ADS8361	16	500	4 Diff	SPI	±2.5 V	Int/Ext	150	ADS8361EVM	SSOP-24, QFN-32	9.19
ADS7886	12	1000	1 SE	SPI	0 - V ₀₀ V	Supply	3.9	ADS7886EVM	SOT23-6, SC70-6	1.70
ADS7883	12	3000	1 SE	SPI	0 - V ₀₀ V	Supply	13.5	ADS7883EVM	SOT23-6	1.85

*Suggested resale price in U.S. dollars in quantities of 1,000.

Preview products are listed in **bold blue**.

Industrial Ethernet

Device	Interface	Cable Lenth (m)	No. LEDs	JTAG	Cable Diagnostics	FX Support	IEEE1588 HW Support	25 MHz Clock Out	Temp Range (°C)	Package
DP838481	MII, RMII, SNI	150	3	YES	—	—	—	YES	-40 to 85	QFP-48
DP83848Q*	MII, RMII	150	1	—	—	—	—	YES	-40 to 105	QFP-40
TLK110	MII, RMII	150	3	YES	YES	—	—	YES	-40 to 85	QFP-48
DP83630	MII, RMII	150	3	YES	YES	YES	YES	YES	-40 to 85	QFP-48
TLK105	MII, RMII	150	1	—	—	—	—	—	-40 to 85	QFP-32
TLK105L*	MII, RMII	150	2	—	—	YES	—	—	-40 to 85	QFP-32
TLK106	MII, RMII	150	1	—	YES	—	—	—	-40 to 105	QFP-32
TLK106L	MII, RMII	150	2	—	YES	YES	—	—	-40 to 105	QFP-32
TLK111	MII, RMII	150	3	—	—	—	SDF	—	-40 to 8	QFP-48
DP83848K	MII, RMII	137	2	—	—	—	—	—	-40 to 85	QFP-40
DP83848T	MII, RMII	137	1	—	—	—	—	YES	-40 to 85	QFP-40
DP83848H	MII, RMII	137	1	—	—	—	—	YES	-40 to 125	QFP-40
DP83620	MII	150	3	YES	YES	YES	—	YES	-40 to 85	QFP-48
DP83640	MII, RMII	150	3	YES	YES	YES	YES	YES	-40 to 85	QFP-48
DP83848VYB	MII, RMII, SNI	150	3	YES	—	—	—	YES	-40 to 105	QFP-48
DP83848YB	MII, RMII, SNI	150	3	YES	—	—	—	YES	-40 to 125	QFP-48

*AEC-Q100 Grade 2, FX support for TLK105L.

New products are listed in **bold red**.

LDO Linear Regulators

Part Number	Description	Output Options	I _{out} (Max) (A)	V _{in} (Min) (V)	V _{in} (Max) (V)	V _{out} (Min) (V)	V _{out} (Max) (V)	I _q (Typ) (mA)	V _{do} (Typ) (mV)	Additional Features	Operating Temperature Range (°C)	Pin/Package	Price* (US\$)
TPS7A4901	Vin 3V to 36V, 150mA, ultra-low noise, high PSRR, low-dropout linear regulator	Adjustable output	0.15	3	36	1.2	33	0.06	260	Over current protection, Thermal shutdown, Enable, Soft start	-40 to 125	8/MSOP-PowerPAD	1.10
TPS7A3001	Vin -3V to -36V, -200mA, ultra-low noise, high PSRR, low-dropout linear regulator	Adjustable output, Negative output	0.2	-3	-36	-1.18	-33	0.05	216	Soft start, Enable, Over current protection, Thermal shutdown	-40 to 125	8/MSOP-PowerPAD	1.50
TLV700	200mA, Low IQ, Low dropout regulator	Fixed 1.2V, 1.3V, 1.5V, 1.8V, 1.9V, 2.2V, 2.5V, 2.8V, 2.9V, 3.0V, 3.1V, 3.2V, 3.3V, 3.6V	0.2	2	5.5	Fixed outputs	Fixed outputs	0.03	175	Enable, Over current protection, Thermal shutdown	-40 to 125	5/SC-70, 5/SOT, 6/WSON	0.13
TLV704	24V, 150mA, Ultra-low IQ, High Vin, Low-dropout regulator	Fixed 3.0V, 3.3V, 3.6V, 5.0V	0.15	2.5	24	Fixed outputs	Fixed outputs	0.003	400	Stable with any capacitor (> 0.47 µF), Over current protection	-40 to 125	5/SOT	0.25
TPS75005	Dual, 500-mA Low-dropout regulators and triple-voltage rail monitor	Adjustable output, Fixed outputs 1.8, 1.9, 3.3	0.5	4	6.5	Fixed outputs	Fixed outputs	0.175	300	Enable, Over current protection, Thermal shutdown, PG, Sequencing and monitoring, Soft start	-40 to 125	20/VQFN	1.90

*Suggested resale price in U.S. dollars in quantities of 1,000.

Preview products are listed in **bold blue**.

Signal Chain Solutions

Digital Isolators

The TI Edge

Reliability

TI offers proven reliability of silicon-dioxide (SiO₂) insulation that is stable over temperature and moisture and has a life span of over 25 years.

Highest Noise Immunity

TI uses differential signals to cross the isolation barrier, giving the highest immunity from external magnetic and electric fields to prevent data corruption.

Signaling Rate

TI offers digital isolators with high signaling rates of up to 150 Mbps, with low skew and pulse-width distortion.

Lowest Jitter

To ensure signal integrity, jitter reduction is a priority. ISO7xxx products offer the lowest jitter of 1-ns jitter at 150-Mbps PRBS NRZ data input.

TI ISO Life Expectancy vs. Voltage

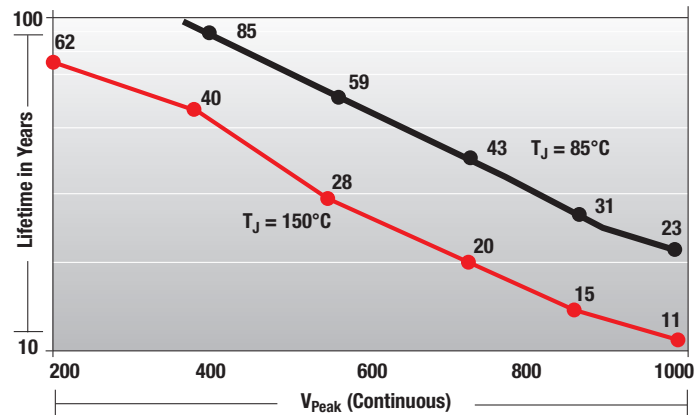

Resources Available

- EVMs
- IBIS models
- Application notes on high-voltage lifetime and magnetic-field immunity

ISO5500 Family Isolated Gate Drivers

TI's ISO5500 products are isolated gate drivers for IGBTs with power ratings up to 150 A and 1200 V.

The input TTL logic and output power stage are separated by TI's silicon-dioxide (SiO₂) isolation barrier

When used in conjunction with isolated power supplies, the device blocks high voltage, isolates grounds and prevents noise currents from entering the local ground and interfering with or damaging sensitive circuitry. dards or specifications.

Key Features

- Soft IGBT turn-off
- Isolated fault feedback
- VCE DESAT protection/adjustability
- Undervoltage lock-out (UVLO) protection with hysteresis
- ±50-kV/μs typical transient immunity
- 6000-V_{peak} maximum isolation per UL
- Operates with 3.3- or 5-V input supply
- -40 to 125°C operating range

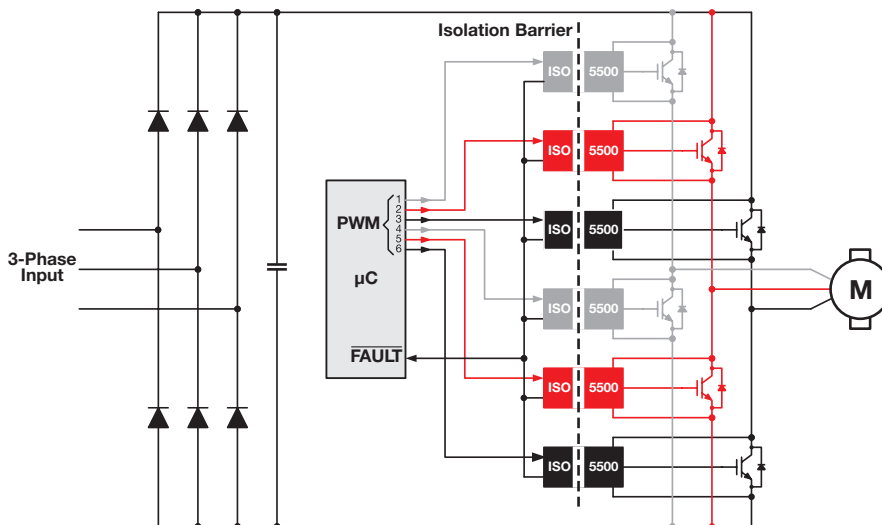

Microcontrollers for Motor Control

C2000™ 32-Bit Real-Time Microcontrollers

Broadest MCU Architecture

- Three MCU families: Piccolo™, Delfino™ and F28M3x series
- 40- to 300-MHz performance
- Dual-core MCUs with CLA coprocessor
- Communications and math acceleration with VCU accelerator
- ARM® Cortex™-M3 and C28x™ dual-core

Real-Time Control

- Optimized DSP core with fast interrupts
- Flexible interrupt system
- Best-in-class ADC performance
- Real-time debugging
- Robust, high-resolution PWMs
- Sensor interfaces
- Serial, CAN, LIN, USB and Ethernet
- Integrated safety features

Overall System-Performance

Optimization

- High level of integration
- Control and supervision
- Variable-speed real-time control
- Better dynamic and transient control
- Simulation, prototyping and automatic code generation from The MathWorks, VisSim and PowerSim
- Software libraries for industrial safety certification such as IEC60730

Piccolo MCU Family for Lowest System Cost

- Integrated OSC, watchdogs, POR/BOR
- Analog comparators and fault detection
- Reduced life-support costs
- No external GPIO filters needed
- High-resolution PWMs and fast ADC
- CLA coprocessor and VCU accelerator
- Floating-point unit
- Serial, USB, CAN, and LIN communications

Delfino MCU Family for High Performance

- High-performance C28x core
- Floating-point unit
- Leading high-resolution PWM
- Industry-leading fast ADC
- Fault detection

F28M3x MCU Family for Maximum System Flexibility

- C28x + ARM® Cortex™-M3 dual-subsystem
- Integrated safety features
- Ethernet, USB and CAN communications peripherals
- Compatible with existing C2000™ application libraries
- Dual, fast ADCs
- High-resolution PWMs
- Floating-point unit and VCU accelerator
- Analog comparators, fault detection, integrated OSC, watchdogs, POR/BOR

Motor Control Software

- Fundamental math, transforms, control, specialized libraries, and peripheral drivers
- With thorough technical documentation
- Delivered through Macro (controlSUITE™) or API (MotorWare™) based C code
- Built into example projects demonstrating
 - Sensored (hall, encoders, resolvers)
 - Sensorless (software observers)
 - Torque, speed, and position control
 - For BLDC, PMSM, and ACI motors
- InstaSPIN™-BLDC, InstaSPIN-FOC, and InstaSPIN-MOTION provide further automated tuning for full motor control systems

Applications

- HVAC compressors and blowers
- Industrial motors
- Variable-speed fans and pumps
- Automotive power steering, traction and pumps
- Premium e-bikes
- Laundry machines
- Medical pumps and blowers

C2000™ Device Features

www.ti.com/c2000

Feature	Fixed-Point			Piccolo™ Series				Delfino™ Series		F28M3x Series	
	F281x	F280x	F2823x	F2802x	F2803x	F2805x	F2806x	F2833x	C2834x	F28M35x	F28M36x
Mass Production	2003	2005	2008	2009	2010	2012	2011	2008	2009	2013	2013
C28x™ CPU	Fixed	Fixed	Fixed	Fixed	Fixed + CLA Option	Fixed + CLA Option	Floating Point + CLA + VCU	Float	Float	Floating Point + ARM® Cortex™-M3	Floating Point + ARM® Cortex™-M3
MHz	150	60 to 100	100 to 150	40 to 60	60 + 60 (CLA)	60	80	100 to 150	200 to 300	75 to 150 (C28x) 100 to 125 (ARM M3)	75 to 150 (C28x) 100 to 125 (ARM M3)
Pins	128 to 179	100	176 to 179	38 to 56	56 to 80	80	80 to 100	176 to 179	176 to 256	289	289
Flash (KB)	128 to 256	32 to 256	128 to 512	16 to 64	32 to 128	32 to 128	128 to 256	128 to 512	0	1025 to 1536	1025 to 1536
RAM (KB)	36	12 to 36	52 to 68	4 to 12	12 to 20	12 to 20	52 to 100	52 to 68	196 to 516	136 to 232	136 to 232
Budgetary Pricing (\$)	13 to 15	3 to 13	13 to 14	1.85 to 3	3 to 4.50	3 to 5	4.95 to 7	14 to 16	9 to 16	12 to 22	12 to 22

Microcontrollers for Motor Control

C2000™ 32-Bit Real-Time Microcontrollers

controlSUITE™ Digital Motor Control (DMC) Library

Transforms and Estimators

- Clarke, Park, sliding mode observer (SMO), phase voltage, resolver, flux, speed calculators and estimators

Control

- Signal generation, closed-loop PID, BEMF commutation, space vector generators, microstep SIN/COB tables

Peripheral Drivers

- Different modes and topology support
- ADC, PWM, encoders, sensor captures, DAC outputs

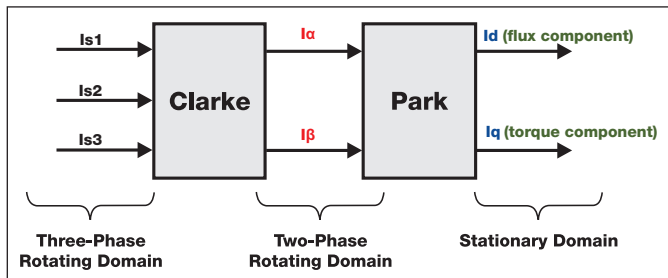

Ex: Using "Park" from DMC Library

```
//initialization code, define macro per library
#define PARK_MACRO(v)
v.Ds = _IQmpy(v.Alpha,v.Cosine) + _IQmpy(v.Beta,v.Sine);
v.Qs = _IQmpy(v.Beta,v.Cosine) - _IQmpy(v.Alpha,v.Sine);

//incremental build code, connect outputs and inputs
park1.Alpha = clarke1.Alpha;
park1.Beta = clarke1.Beta;

//run-time code, call the function
PARK_MACRO(park1)
```

Learn more at: www.ti.com/c2000dmc

F

Rotor Flux

- High integrity signal for stable field control

Rotor Angle

- Locks within one electrical cycle of rotation
- Stable through zero
- Robust under dynamics
- Recovery after stall events

A

Rotor Speed

- Mechanical and electrical speed estimations
- Near zero phase lag

S

Rotor Torque

- Accurate for load monitoring, flow rate, unbalanced load, motor diagnostics

T

FAST™ Software Encoder (Sensorless Observer)

- Universal 3-phase motor software encoder supports
 - Synchronous (BLDC, SPM, IPM)
 - Asynchronous (ACI) motors
 - Unique, high-quality feedback signals for use in control systems
- Performance
 - Tracks below 1 Hz
 - Tracks through zero on speed reversals
 - Stable feedback to control system when rotor is at zero speed
- Motor parameters
 - Relies on fewer parameters than other observers
 - Off-line commissioning learns the needed electrical motor parameters
 - Optional on-line observer tracks parameter changes to ensure estimation accuracy over time and temperature
- Tuning
 - No tuning of the observer required

Included in ROM on select Piccolo™ MCUs, with software API



Microcontrollers for Control

Tiva™ C Series Kits

Texas Instruments is the industry leader in bringing 32-bit capabilities and the full benefits of ARM® Cortex™-M-based microcontrollers to market. MCUs with Cortex-M offer a direct path to the strongest ecosystem of development tools, software and knowledge in the industry. Designers who migrate to MCUs will benefit from great tools, small code footprint and outstanding performance.

With large on-chip memories, enhanced power management and expanded I/O and control capabilities, MCUs are optimized for industrial applications requiring reliable connectivity, precise motor/motion control and remote monitoring. Some typical applications are factory automation, HVAC and building control, gaming equipment, medical instrumentation, consumer appliances, CCTV monitoring and fire security

Precision Motion Control

The microcontrollers features deterministic performance and IP especially designed for simultaneous advanced motion control and real-time connectivity. These microcontrollers include up to 16 full channels of control with deadband generators and shoot-through protection for applications such as three-phase inverter bridges. Fault-condition handling in hardware quickly provides low-latency shutdown and synchronization of timers to enable precise alignment of all edges.

- Motion-control PWMs with deadband and fault detection support safe and efficient operation of motors
- Quadrature encoder inputs (QEIs) support incremental encoders, tachometers, generators/resolvers and TDC detectors
- High-speed ADCs support current measurement using Hall sensors or shunts to optimize algorithms
- Independent integrated analog comparators can be configured to drive an output or generate an ADC interrupt event

Key Features

- Interleaved average current-mode PWM control with inherent current matching
- ARM Cortex-M4F core
- 32 to 256KB of flash
- 80-MHz CPU clock speeds
- Deterministic fast-interrupt processing (12 cycles)
- Real-time multitasking capabilities
- Integrated analog peripherals
- 12-bit analog-to-digital converter
- Pulse-width modulators (PWMs) with programmable deadband timers
- Operating modes with clock gating for lower power
- Single-cycle multiply/accumulate (MAC)
- IEEE 754 single-precision floating-point unit (FPU)

Unique MCU Capabilities

- Two CAN protocol version 2.0 part A/B
- Advanced communication capabilities, including UARTs, synchronous serial interfaces, USB, USB OTG, CAN controllers and I2C
- 5-V tolerant GPIOs with programmable drive capability
- Single-cycle flash up to 40 MHz
- Royalty-free software with serial bootloaders and DriverLib available in ROM
- Open-tooled reference design kits and quick-start evaluation kits
- Up to two quadrature encoder inputs

Ware Software

- Extensive suite of software designed to reduce development cycle time
- Peripheral library
- USB library
- Graphics library
- Code examples
- Available as object library and source code

Hardware Kits

- Schematics, BOM and Gerber files are available for all hardware kits and include all accessories to start evaluation and software development.

For more information on MCUs for motor-control applications, visit www.ti.com/c2000

Microcontrollers for Control

Tiva™ C Series Kits

Evaluation kit

EK-TM4C123GXL LaunchPad Evaluation Kit is the perfect kit to get started with a Tiva C Series microcontroller at just U.S. \$12.99.

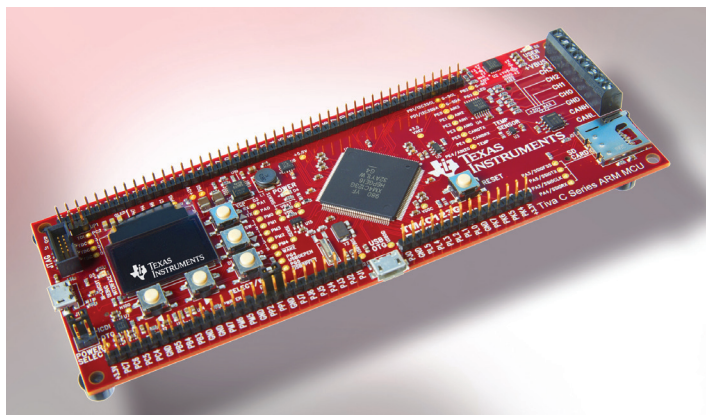
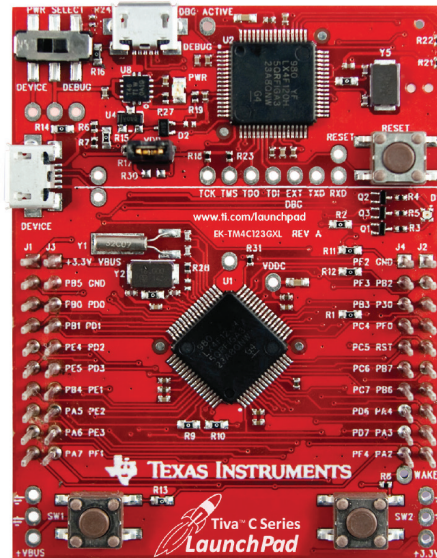

Development Kits

The Tiva C Series TM4C123G Development Kit is a compact and versatile evaluation platform for the Tiva C Series TM4C123G ARM® Cortex™-M4-based microcontroller (MCU). The development kit design highlights the TM4C123G MCU integrated USB 2.0 On-the-Go/Host/Device interface, CAN, precision analog, sensor hub, and low-power capabilities. The development kit features a Tiva C Series TM4C123GH6PGE microcontroller in a 144-LQFP package, a color OLED display, USB OTG connector, a microSD card slot, a coin-cell battery for the low-power Hibernate mode, a CAN transceiver, a temperature sensor, a nine-axis sensor for motion tracking, and easy-access through-holes to all of the available device signals.

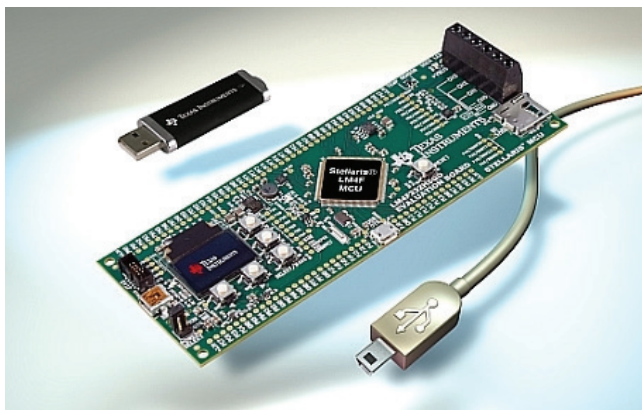

The EK-LM4F232 Development Kit is a compact and versatile tool for the Tiva C Series TM4C123G ARM® Cortex™-M4F based MCU. Key highlights include a color OLED display, USB OTG, a micro SD card, a coin cell battery for use with low-power hibernate, a temperature sensor, a three axis accelerometer for motion detection, and easy-access through-holes to all of the available device signals.

Microcontrollers for Motor Control

Hercules™ TMS570 32-Bit ARM® Cortex™-R4 Safety Microcontrollers

Hercules™ TMS570 Safety MCUs Enable Safe Motor Control

The Hercules TMS570 microcontroller family enables customers to easily build motor-control applications that meet specific safety standards. Devices are available today with up to 220 MHz of floating-point performance and include an integrated safety concept.

A wide choice of communication peripherals like Ethernet, CAN, USB, FlexRay® and LIN, in combination with a powerful high-end timer (HET) coprocessor module, makes the family a flexible solution for safety-critical control applications.

The Hercules TMS570 Cortex™-R4 microcontroller family was developed according to the ISO26262 ASIL-D and IEC 61508 SIL3 safety standards. Dual-core lockstep CPU architecture, hardware BIST, MPU, ECC and on-chip clock and voltage monitoring are some of the key functional safety features available. A safety manual is available with guidelines on how to make the safety implementation as easy as possible.

Key Features

ARM® Cortex-R4 CPUs

- Up to 220 MHz with floating-point support
- Dual CPUs in lockstep

Memory

- Flash: 1MB, 2MB, and 3MB options with ECC protection
- RAM: 128KB to 256KB with ECC protection
- Roadmap from 256KB to 4MB flash

Peripheral Highlights

- 10/100 Ethernet
- USB host and device
- FlexRay with 8KB message RAM
- Three CAN interfaces
- Two 12-bit multi-buffered ADCs (MibADCs)
- Flexible timer module with up to 44 channels

Packages

- 144 QFP, 337 nFBGA (16.16 mm)

Applications

- Electronic power steering
- Hybrid and electric vehicles
- Medical pumps and blowers
- Industrial motors

Motor Control Benefits

High-End Timer (HET) Coprocessor

- Effective support of many motor control concepts due to HET programmability
 - PWM generation – symmetric, asymmetric, deadband
 - Single- or multiple-shunt systems
 - Quadrature decoding
 - HET can trigger the ADC(s) with many configuration possibilities

32-bit ARM Cortex-R4 with Floating-Point Unit

- IEEE 754 compliant floating point unit (ARM VFPv3D16)
- Supports both single and double precision

Hercules™ TMS570 Safety MCU

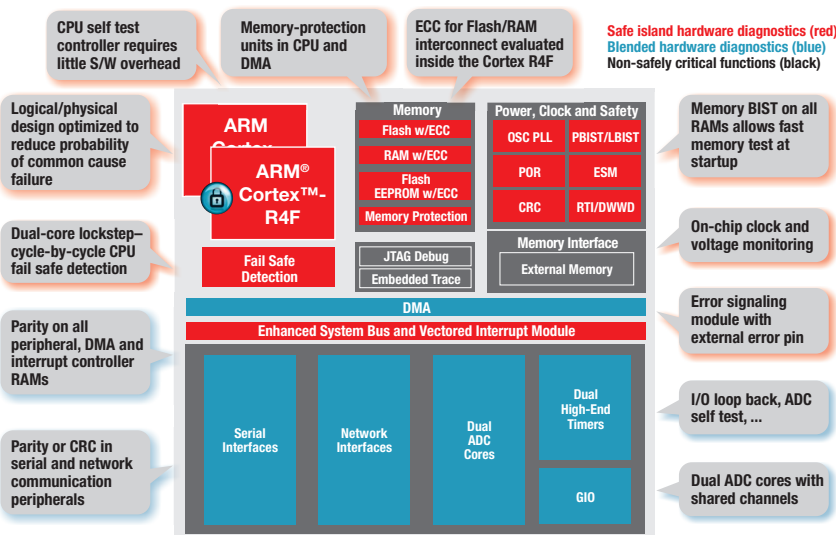
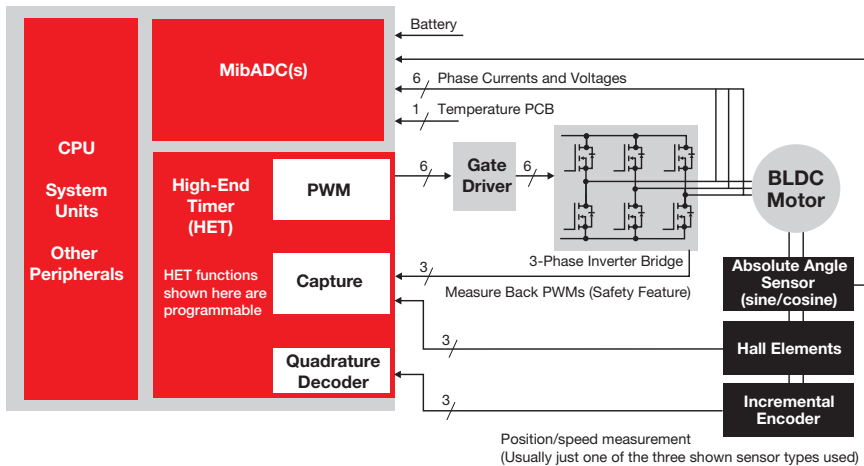

Learn more at: www.ti.com/hercules

Special Purpose Processors for Motion Control

Trajectory controllers

The LM628 and LM629 are dedicated motion-control processors designed for use with a variety of DC servo motors and other servo mechanisms which provide a quadrature incremental position feedback signal. The parts perform the intensive, real-time computational tasks required for high-performance digital motion control and

the host software control interface is facilitated by a high-level command set. The LM628 has an 8-bit output to drive either an 8-bit or a 12-bit DAC. The LM629 has an 8-bit PWM output to directly drive LMD18200/201 H-Bridges.

Key Features

- 32-bit position, velocity, and acceleration registers
- Programmable digital PID filter with 16-bit coefficients
- Direct interface to Quadrature encoder interface
- 8- or 12-bit DAC output data (LM628)
- 8-bit sign-magnitude PWM output data (LM629)

Featured Products

Device	Clock freq	Host interface	Shift encoder interface	Drive interface	Package
LM628	6 or 8 MHz	8 bit, CS, RD, WR	A, B quadrature; Index	8 bit to DAC	28 PDIP
LM629	6 or 8 MHz	8 bit, CS, RD, WR	A, B quadrature; Index	PWM sign, magnitude	24 SOIC, 28 PDIP

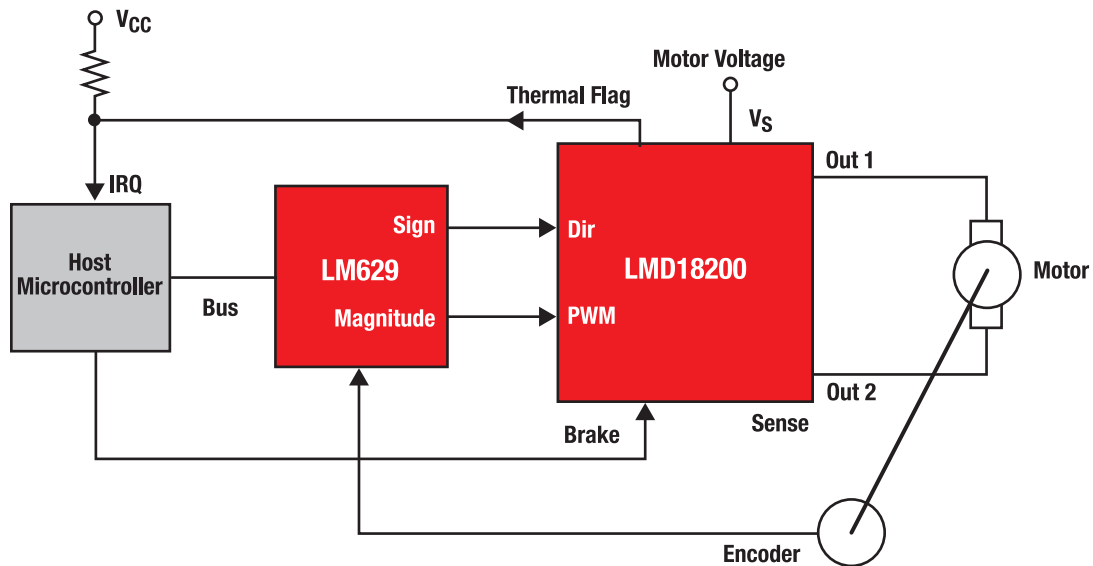

Precision Control of DC Servo Motor

Integrated Fan Motor Drivers

The TI Advantage – Maximum Integration

The integrated fan motor driver family incorporates a driving stage with either the sensed, or the sensor-less InstaSPIN™-FAN BLDC motor control logic. No code or external devices are required to safely and reliably spin the motor, minimizing both software and hardware efforts. Over and under-voltage, configurable

over-current and over-temperature protection are automatically provided. The high integration enables a much cleaner and safer board as compared with traditional “MCU + discrete components” solution, simplifying and speeding design process.

With both driver and pre-driver products, the fan driver family is able to spin not only fans in various cooling applications, but also low-/mid-voltage BLDC motors in consumer and industrial applications.

Featured Products

Product Type	Device	Voltage / Current	Description
Drivers	DRV10963	2.1 to 5.5V / 500mA	180° 3-phase sensor-less BLDC fan driver
	DRV11873	5 to 16V 1.5A	150° 3-phase sensor-less fan driver
Pre-drivers	TMP816	6 to 16V 50mA	1-phase full-wave sensed fan pre-driver

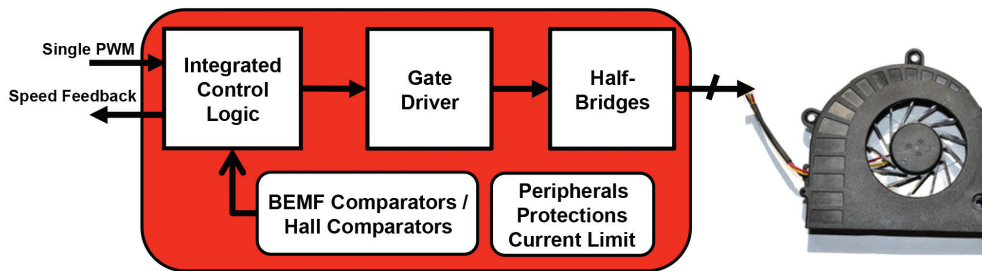

Integrated Fan Motor Drivers

Device	Description	Supply Voltage (V)	IOUT (mA)	On-Chip Regulator	Price*
BLDC Fan Motor Drivers					
DRV10866	5V 3-phase sensor-less BLDC driver (InstaSPIN™-FAN)	1.65 to 5.5	3.3, 5	No	0.39
DRV10963	5V 3-phase sinusoidal sensor-less BLDC driver (InstaSPIN™-FAN)	2.1 to 5.5	3.3, 5	No	TBD
DRV11873	12V 3-phase sensor-less BLDC driver (InstaSPIN™-FAN)	5 to 16	3.3, 5	Yes (5V)	0.79
BLDC Fan Motor Pre-Drivers					
TMP814	1-phase full-wave sensed BLDC fan motor pre-driver	6 to 16	Ext FETs	Yes (6V)	0.25
TMP815	1-phase full-wave sensed BLDC fan motor pre-driver	6 to 16	Ext FETs	Yes (4.95V)	0.25
TMP816	1-phase full-wave sensed BLDC fan motor pre-driver	6 to 16	Ext FETs	Yes (6V)	0.26
TMP821	2-phase half-wave sensed BLDC fan motor pre-driver	4 to 28	Ext FETs	No	0.24

*Suggested resale price in U.S. dollars in quantities of 1,000. See www.ti.com/hirel for HiRel options.

New products are listed in **bold red**. Preview products are listed in **bold blue**.

Selection Guides for Analog Motor Solutions

Stepper Motor Drivers

www.ti.com/motor

Device	Description	Supply Voltage (V)	I _{OUT} Cont. (A)	I _{OUT} Peak (A)	Control Interface	Drives Solenoids	Price*
DRV8412	6-A high-performance stepper driver	0 to 52	3	6	PWM	Yes (4x)	3.85
DRV8432	12-A high-performance stepper driver	0 to 52	7	12	PWM	Yes (4x)	5.50
DRV8812	1.6-A stepper driver (P2P w/8813)	8 to 45	1.1	1.6	Phase/Enable	No	1.65
DRV8813	2.5-A stepper driver (P2P w/8812)	8 to 45	1.75	2.5	Phase/Enable	No	2.25
DRV8823	Dual 1.5-A stepper driver	8 to 32	1.5	1.5	Serial	No	2.00
DRV8828	3-A stepper driver (need 2x per motor)	8 to 45	2.1	3	Phase/Enable	No	1.65
DRV8829	5-A stepper driver (need 2x per motor)	8 to 45	3.5	5	Phase/Enable	No	2.25
DRV8842	5-A stepper driver (need 2x per motor)	8 to 45	3.5	5	PWM	Yes (2x)	2.25
DRV8843	2.5-A stepper driver	8 to 45	1.75	2.5	PWM	No	2.25
Stepper Drivers w/ On-Chip Micro-Stepping Indexer							
DRV8811	1.9-A stepper driver (8 microsteps) (P2P w/8818)	8 to 38	1.4	1.9	Indexer	No	1.80
DRV8818	2.5-A stepper driver (8 microsteps) (P2P w/8811)	8 to 35	1.75	2.5	Indexer	No	2.25
DRV8821	Dual 1.5-A stepper driver (8 microsteps)	8 to 32	1.5	1.5	Indexer	No	2.00
DRV8824	1.6-A stepper driver (32 microsteps) (P2P w/8825)	8 to 45	1.1	1.6	Indexer	No	1.65
DRV8825	2.5-A stepper driver (32 microsteps) (P2P w/8824)	8 to 45	1.75	2.5	Indexer	No	2.40
Unipolar Stepper Drivers							
DRV8803	2-A unipolar stepper driver	8 to 60	2	2	PWM	Yes (4x)	1.40
DRV8804	2-A unipolar stepper driver	8 to 60	2	2	Serial	Yes (4x)	1.40
DRV8805	2-A unipolar stepper driver w/indexer	8 to 60	2	2	Indexer	No	1.40
DRV8806	2-A unipolar stepper driver w/open load detect	8 to 40	2	2	Serial	Yes (4x)	1.50
Low-Voltage Stepper Drivers							
DRV8833	2-A stepper driver	2.7 to 10.8	1.5	2	PWM	No	0.95
DRV8834	2.2-A stepper driver (32 microsteps)	2.5 to 10.8	1.5	2.2	Indexer or Phase/Enable	No	1.15
DRV8835	1.5-A stepper driver w/dual supplies	2.0 to 11	1.5	1.5	PWM or Phase/Enable	No	0.70
DRV8836	1.5-A stepper driver	2.0 to 7	1.5	1.5	PWM or Phase/Enable	No	0.70
Stepper Pre-Driver							
DRV8711	Stepper pre-driver w/ on-chip 1/256 μ Stepping indexer and stall detect	8 to 52	Ext FETs	Ext FETs	Indexer, PWM or Serial	No	2.75

*Suggested resale price in U.S. dollars in quantities of 1,000.

New products are listed in **bold red**.

Selection Guides for Analog Motor Solutions

Brushed and Brushless DC Motor Drivers

www.ti.com/motor

Device	Description	Supply Voltage (V)	I _{OUT} Cont. (A)	I _{OUT} Peak (A)	Control Interface	Drives Solenoids	Price*
DRV8301	Pre-driver with 1.5-A step-down voltage regulator and dual current-sense amps (SPI control)	8 to 60	Ext FETs	Ext FETs	PWM	No	2.50
DRV8302	Pre-driver with 1.5-A step-down voltage regulator and dual current-sense amps (H/W control)	8 to 60	Ext FETs	Ext FETs	PWM	No	2.50
DRV8412	12-A high-performance brushed DC driver	0 to 52	6	12	PWM	Yes (4x)	3.85
DRV8432	24-A high-performance brushed DC driver	0 to 52	14	24	PWM	Yes (4x)	5.50
DRV8800	2.8-A brushed DC driver	8 to 36	1.5	2.8	Phase/Enable	No	1.25
DRV8801	2.8-A brushed DC driver w/current-sense pin	8 to 36	1.5	2.8	Phase/Enable	No	1.25
DRV8840	5-A brushed DC driver	8 to 45	3.5	5	Phase/Enable	No	2.25
DRV8842	5-A brushed DC driver	8 to 45	3.5	5	PWM	Yes (2x)	2.25
DRV8844	5-A brushed DC driver w/split supply support (+30/-30)	8 to 60	3.5	5	PWM	Yes (4x)	2.50
LMD18200	3A, 55V H-Bridge for DC Motors	12 to 55	3	6	PWM	No	8.10
LMD18201	3A, 55V H-Bridge for DC Motors	12 to 55	3	6	PWM	No	7.70
LMD18245	3A, 55V H-Bridge for DC Motors	12 to 55	3	6	4bit Digital	No	9.15
Dual/Triple/Quad Brushed Drivers							
DRV8412	Dual 6-A high-performance brushed DC driver	0 to 52	3	6	PWM	Yes (4x)	3.85
DRV8432	Dual 12-A high-performance brushed DC driver	0 to 52	7	12	PWM	Yes (4x)	5.50
DRV8802	Dual 1.6-A brushed DC driver (P2P w/8814)	8 to 45	1.1	1.6	Phase/Enable	No	1.65
DRV8814	Dual 2.5-A brushed DC driver (P2P w/8802)	8 to 45	1.75	2.5	Phase/Enable	No	2.25
DRV8823	Quad 1.5-A brushed DC driver	8 to 32	1.5	1.5	Serial	No	2.00
DRV8843	Dual 2.5-A brushed DC driver	8 to 45	1.75	2.5	PWM	No	2.25
DRV8844	Dual 2.5-A brushed DC driver w/split supply support (+30/-30)	8 to 60	1.75	2.5	PWM	Yes (4x)	2.50
DRV8313	Triple 2.5A brushed DC driver	8 to 60V	1.75	2.5	Phase/Enable I/F	Yes (3x)	2.25
Low-Voltage Brushed Drivers							
DRV8830	1-A brushed DC driver w/on-chip speed regulation	2.75 to 6.8	1	1	IN/IN	No	0.85
DRV8832	1-A brushed DC driver w/on-chip speed regulation	2.75 to 6.8	1	1	Serial	No	0.85
DRV8833	Dual 2-A or single 4-A brushed DC driver	2.7 to 10.8	3	4	PWM	No	0.95
DRV8835	Dual 1.5-A or single 3-A brushed DC driver w/dual supplies	2.0 to 11	3	3	PWM or Phase/Enable	No	0.70
DRV8836	Dual 1.5-A or single 3-A brushed DC driver	2.0 to 7	3	3	PWM or Phase/Enable	No	0.70
DRV8837	1.8-A brushed DC driver w/dual supplies	1.8 to 11	1.8	1.8	PWM	No	0.45
DRV8839	Dual 1.8A or single 1.8A brushed DC driver	1.8 to 11	1.8	1.8	PWM	Yes (2x)	0.50
3-Phase Brushless Motors							
DRV8301	Pre-driver with 1.5-A step-down voltage regulator and dual current-sense amps (SPI control)	6 to 60	Ext FETs	Ext FETs	PWM	No	2.50
DRV8302	Pre-driver with 1.5-A step-down voltage regulator and dual current-sense amps (H/W control)	6 to 60	Ext FETs	Ext FETs	PWM	No	2.50
DRV8312	6.5-A high-performance 3-phase driver	0 to 52	3.5	6.5	PWM	Yes (3x)	3.30
DRV8313	2.5-A 3-phase driver w/10-mA LDO	8 to 60	1.75	2.5	PWM	Yes (3x)	2.25
DRV8332	13-A high performance 3-phase driver	0 to 52	8	13	PWM	Yes (3x)	4.70
DRV8303	Pre-driver with dual current-sense amps (SPI control)	6 to 60	Ext FETs	Ext FETs	PWM	No	TBD

*Suggested resale price in U.S. dollars in quantities of 1,000.

New products are listed in **bold red**. Preview products are listed in **bold blue**.

Selection Guides for Analog Motor Solutions

CAN Transceivers (CANopen systems compliant)

Device	Description	Isolated	Supply Voltage (V)	I/O Levels	Short-Circuit Protection (V)	ESD (kV)	Operating Temp Range (°C)	HiRel Avail.	Price*
SN65HVD255	Turbo CAN: Fast loop times, next gen for '251 and '1050	No	5	5-V TTL	-27 to 40	±12	-40 to 125	No	0.50
SN65HVD256	Turbo CAN: Fast loop times, IO level shifting	No	5	5-V TTL	-27 to 40	±12	-40 to 125	No	0.50
SN65HVD257	Turbo CAN: Fast loop times, bus redundancy	No	5	5-V TTL	-27 to 40	±12	-40 to 125	No	0.60
ISO1050DW	5-kV _{rms} isolated CAN transceiver	Yes	5	5-V TTL	-27 to 40	±4	-55 to 105	No	1.95
SN65HVD251	Improved replacement for PCA82C250 and PCA82C251/small QFN package	No	5	5-V CMOS	-36 to 36	±14	-40 to 125/ -55 to 125	Yes	0.90
SN65HVD1040	Improved TJA1040 with better ESD and bus wake-up	No	5	5-V TTL	-27 to 40	±12	-40 to 125	Yes	0.60
SN65HVD1050	Improved TJA1050 with better ESD	No	5	5-V TTL	-27 to 40	±8	-40 to 125	Yes	0.45
ISO1050DUB	2.5-kV _{rms} isolated CAN transceiver	Yes	5	5-V TTL	-27 to 40	±4	-55 to 105	No	1.55
SN65HVD232	Cost-effective	No	3.3	3.3-V TTL	-4 to 16	±16	-40 to 85	Yes	1.10

*Suggested resale price in U.S. dollars in quantities of 1,000. See www.ti.com/hirel for HiRel options.

New products are listed in bold red.

Digital Isolators

Device	Description	Isolation Rating (UL, VDE, CSA) (V _{rms})	Channel Direction	Data Rate (max) (Mbps)	Transient Immunity (min) (kV/μs)	Supply Voltage (V)	HiRel Avail.	Price*
ISO721/M	Single channel	2500	1/0	100/150	25	3.3, 5	Yes	1.40
ISO7230C/M	Triple channel	2500	3/0	25/150	25	3.3, 5	No	1.40
ISO7231C/M	Triple channel	2500	2/1	25/150	25	3.3, 5	No	1.40
ISO7240C/CF/M	Quad channel (F = Fail-safe low)	2500	4/0	25/25/150	25	3.3, 5	Yes	1.75
ISO7241C/M	Quad channel	2500	3/1	25/150	25	3.3, 5	Yes	1.75
ISO7242C/M	Quad channel	2500	2/2	25/150	25	3.3, 5	No	1.75
ISO7420E/FE/FCC ISO7421E/FE/FCC	Gen II dual-channel (F = Fail-safe low, CC = noise filter)	2500	2/0 and 1/1	50	50	3.3, 5	No	1.05
ISO7640FM/41FM	Gen II quad-channel (F = Fail-safe low)	4243	4/0 and 3/1	150	75	3.3, 5	No	2.50

*Suggested resale price in U.S. dollars in quantities of 1,000. See www.ti.com/hirel for HiRel options.

New products are listed in bold red. Preview products are listed in bold blue.

IGBT Gate Drivers

Device	Description	Isolation Rating (UL, VDE, CSA) (V _{rms})	Channel Direction	Data Rate (max) (Mbps)	Transient Immunity (min) (kV/μs)	Supply Voltage (V)	HiRel Avail.	Price*
ISO5500	2.5 A Isolated IGBT/MOSFET Gate Driver	4243	—	—	±50	-0.5, 6	No	3.00

*Suggested resale price in U.S. dollars in quantities of 1,000. See www.ti.com/hirel for HiRel options.

New products are listed in bold red. Preview products are listed in bold blue.

Selection Guides for Analog Motor Solutions

Power Management

Device	Description	Key Benefits
TPS54062/61	4.7-V to 60-V, 50-mA/200-mA synchronous step-down converter	<ul style="list-style-type: none"> • Small size • High efficiency • Low I_Q
LM5017	100-V, 600-mA constant on-time synchronous buck regulator	<ul style="list-style-type: none"> • Transient protection with no clamping circuitry • 50% BOM reduction compared to controller with no external loop compensation required • Smaller magnetics allows higher power density for tight spaces
TPS54060A/160A/260/360	3.5-V to 60-V input, 0.5/1.5/2.5/3.5-A DC/DC converters	<ul style="list-style-type: none"> • Supports 65-V transients • Small size and low I_Q • Eco-mode for light-load efficiency
UCC28070A	Extended frequency range (10 to 300 kHz), interleaving, continuous-conduction-mode PFC controller	<ul style="list-style-type: none"> • Extended programmable frequency range (10 to 300 kHz) allows the use of high-power IGBT power switches • Advanced current synthesizer current sensing eliminates two current sense transformers, lowering the cost while providing superior power factor and efficiency • Highly linear multiplier output with internal quantized voltage feed-forward correction significantly improves line-transient response and reduces THD; allowing near-unity power factor • Programmable frequency dithering reduces EMI by spreading the energy over a wider range • Numerous protection features increases safety and improves power supply reliability under most potential fault conditions
TPS75005	Power solution for C2000 with dual 500-mA, low-dropout regulators and triple-voltage rail monitor	<ul style="list-style-type: none"> • Optimized for C2000 MCU series: F2833x (Delfino™), F2823x, F281x, and F280x/F2801x • LDO-1 and SVS-1: 1.8 V or 1.9 V, 0.5 A • LDO-2 and SVS-2: 3.3 V, 0.5 A
TPS62404	High-efficiency, dual-output DC/DC converter for C2000	<ul style="list-style-type: none"> • Optimized for C2000 MCU series: F2833x (Delfino), F2823x, F281x and F280x/F2801x • Dynamic voltage scaling for both channels independently possible • Separate enable pins support user-defined sequencing
TPS3700	18- V_{DD} , window comparator for overvoltage and undervoltage detection	<ul style="list-style-type: none"> • Wide supply range: 1.8 to 18 V • High accuracy threshold: 1% (over temp) • Adjustable threshold down to 400 mV • Open-drain OV and UV outputs
LMP8646	Precision current limiter	<ul style="list-style-type: none"> • Provides circuit protection and current limit • Supports any switching or linear regulator with an available feedback node • Simple design with adjustable gain and bandwidth
LM5060	High-Side Protection Controller with Low Quiescent Current	<ul style="list-style-type: none"> • Low Quiescent current • Programmable delay times • Adjustable UVLO and OVP

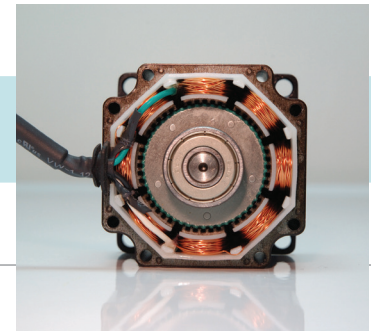

Recommended Products for Industrial Motor Drive and Control

www.ti.com/motor

Description	Device	Key Benefits
Temperature Sensing		
Temperature switch and sensor	LM57	<ul style="list-style-type: none"> • Programmable trip point • External resistors introduce no error • Wide operating temperature -50°C to 150°C • In-situ testing and temperature reading
Analog temperature sensor	LM94022	<ul style="list-style-type: none"> • Selectable gain • Operation down to 1.5 V • Saves system cost by using available ADCs
Remote diode temperature sensor	LM95235	<ul style="list-style-type: none"> • Automotive grade 3 qualification ensures robustness in rugged conditions • TruTherm™ improves sub-micron temperature measurements • Diode fault detect notifies system of status • Programmable hysteresis for flexibility
Industry standard digital temp sensor	LM75A / TMP75	<ul style="list-style-type: none"> • Multiple devices / bus • Stand-alone thermostat operation • Wide operating range of -55°C to 125°C
High resolution and temperature digital temperature sensor	LM95172-Q1	<ul style="list-style-type: none"> • Automotive grade 0 qualified • extended temperature to 200°C • Optimized accuracy specifications from 120°C to 200°C • Available as a die / wafer product
Position Sensing		
Frequency-to-Voltage Converters	LM2907/17	<ul style="list-style-type: none"> • Differential or ground referenced input with hysteresis for direct coupling to magnetic pickups • Floating transistor 50mA output for direct drive to relays, solenoids or LEDs • Wide operating voltage range 6-28V with low operating current less than 5mA

NexFET Power MOSFET

N-Channel

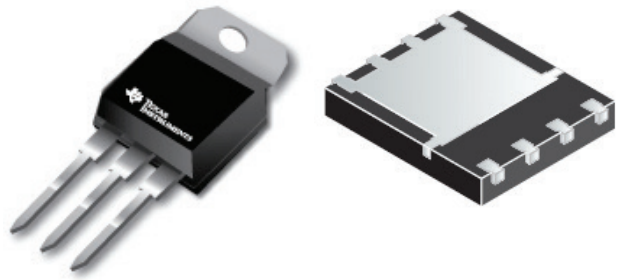

Single N-Channel

Device	Description	BV_{DSS} (V)	Typical $R_{DS(ON)}$ @ 10 V (m Ω)	Maximum $I_D T_C = 25^\circ$ (A)	Package	Price*
CSD18501Q5A	40-V N-Channel NexFET Power MOSFET	40	2.5	155	SON5x6	0.76
CSD18502Q5B	40-V N-Channel NexFET Power MOSFET	40	1.8	204	SON5x6	1.02
CSD18503Q5A	40-V N-Channel NexFET Power MOSFET	40	3.4	145	SON5x6	0.62
CSD18504Q5A	40-V N-Channel NexFET Power MOSFET	40	5.3	75	SON5x6	0.51
CSD18531Q5A	60-V N-Channel NexFET Power MOSFET	60	3.5	134	SON5x6	0.76
CSD18532Q5B	60-V N-Channel NexFET Power MOSFET	60	2.5	172	SON5x6	1.02
CSD18533Q5A	60-V N-Channel NexFET Power MOSFET	60	4.7	103	SON5x6	0.62
CSD18534Q5A	60-V N-Channel NexFET Power MOSFET	60	7.8	69	SON5x6	0.51
CSD18537NQ5A	60-V N-Channel NexFET Power MOSFET	60	10	62	SON5x6	0.42
CSD18502KCS	40-V N-Channel NexFET Power MOSFET	40	2.4	200	TO-220	0.97
CSD18503KCS	40-V N-Channel NexFET Power MOSFET	40	3.6	130	TO-220	0.72
CSD18504KCS	40-V N-Channel NexFET Power MOSFET	40	5.5	85	TO-220	0.58
CSD18532KCS	60-V N-Channel NexFET Power MOSFET	60	3.3	169	TO-220	0.97
CSD18533KCS	60-V N-Channel NexFET Power MOSFET	60	5	114	TO-220	0.72
CSD18534KCS	60-V N-Channel NexFET Power MOSFET	60	7.6	71	TO-220	0.58
CSD18537NKCS	60-V N-Channel NexFET Power MOSFET	60	11	54	TO-220	0.49

*Suggested resale price in U.S. dollars in quantities of 1,000.

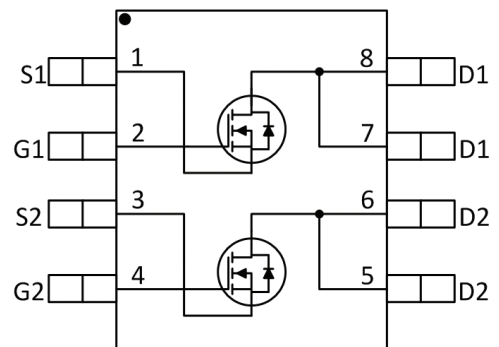
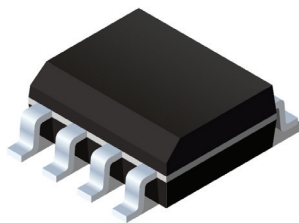

Dual N-Channel

Device	Description	BV_{DSS} (V)	Typical $R_{DS(ON)}$ @ 10 V (m Ω)	Maximum $I_D T_C = 25^\circ$ (A)	Package	Price*
CSD88537ND	60-V Dual N-Channel NexFET Power MOSFETs	60	13	13	S0-8	0.39
CSD88539ND	60-V Dual N-Channel NexFET Power MOSFETs	60	22	7	S0-8	0.53

*Suggested resale price in U.S. dollars in quantities of 1,000.

Preview products are listed in **bold blue**.

TI Worldwide Technical Support

Internet

TI Semiconductor Product Information Center Home Page

support.ti.com

TI E2E™ Community Home Page

e2e.ti.com

Product Information Centers

Americas	Phone	+1(512) 434-1560
Brazil	Phone	0800-891-2616
Mexico	Phone	0800-670-7544
	Fax	+1(972) 927-6377
	Internet/Email	support.ti.com/sc/pic/americas.htm

Europe, Middle East, and Africa

Phone	
European Free Call	00800-ASK-TEXAS (00800 275 83927)
International	+49 (0) 8161 80 2121
Russian Support	+7 (4) 95 98 10 701

Note: The European Free Call (Toll Free) number is not active in all countries. If you have technical difficulty calling the free call number, please use the international number above.

Fax	+ (49) (0) 8161 80 2045
Internet	www.ti.com/asktexas
Direct Email	asktexas@ti.com

Japan

Phone	Domestic	0120-92-3326
Fax	International	+81-3-3344-5317
	Domestic	0120-81-0036
Internet/Email	International	support.ti.com/sc/pic/japan.htm
	Domestic	www.tij.co.jp/pic

The platform bar and E2E are trademarks of Texas Instruments. All other trademarks are the property of their respective owners.

Asia

Phone	
International	+91-80-41381665
Domestic	<u>Toll-Free Number</u>
Note: Toll-free numbers do not support mobile and IP phones.	
Australia	1-800-999-084
China	800-820-8682
Hong Kong	800-96-5941
India	1-800-425-7888
Indonesia	001-803-8861-1006
Korea	080-551-2804
Malaysia	1-800-80-3973
New Zealand	0800-446-934
Philippines	1-800-765-7404
Singapore	800-886-1028
Taiwan	0800-006800
Thailand	001-800-886-0010
Fax	+8621-23073686
Email	tiasia@ti.com or ti-china@ti.com
Internet	support.ti.com/sc/pic/asia.htm

Important Notice: The products and services of Texas Instruments Incorporated and its subsidiaries described herein are sold subject to TI's standard terms and conditions of sale. Customers are advised to obtain the most current and complete information about TI products and services before placing orders. TI assumes no liability for applications assistance, customer's applications or product designs, software performance, or infringement of patents. The publication of information regarding any other company's products or services does not constitute TI's approval, warranty or endorsement thereof.

The platform bar, C2000, C28x, Code Composer Studio, Concerto, controlSUITE, Delfino, E2E, Hercules, InstaSPIN, Piccolo and Sitara are trademarks and PHYTER, Stellaris and StellarisWare are registered trademarks of Texas Instruments. ARM is a registered trademark of ARM Limited and Cortex is a trademark of ARM Limited in EU and/or elsewhere. FlexRay is a registered trademark of DaimlerChrysler AG. MATLAB and Simulink are registered trademarks of The Mathworks, Inc. VisSim/ Embedded Controls Developer is a trademark of Visual Solutions Inc. All other trademarks are the property of their respective owners.

IMPORTANT NOTICE

Texas Instruments Incorporated and its subsidiaries (TI) reserve the right to make corrections, enhancements, improvements and other changes to its semiconductor products and services per JESD46, latest issue, and to discontinue any product or service per JESD48, latest issue. Buyers should obtain the latest relevant information before placing orders and should verify that such information is current and complete. All semiconductor products (also referred to herein as "components") are sold subject to TI's terms and conditions of sale supplied at the time of order acknowledgment.

TI warrants performance of its components to the specifications applicable at the time of sale, in accordance with the warranty in TI's terms and conditions of sale of semiconductor products. Testing and other quality control techniques are used to the extent TI deems necessary to support this warranty. Except where mandated by applicable law, testing of all parameters of each component is not necessarily performed.

TI assumes no liability for applications assistance or the design of Buyers' products. Buyers are responsible for their products and applications using TI components. To minimize the risks associated with Buyers' products and applications, Buyers should provide adequate design and operating safeguards.

TI does not warrant or represent that any license, either express or implied, is granted under any patent right, copyright, mask work right, or other intellectual property right relating to any combination, machine, or process in which TI components or services are used. Information published by TI regarding third-party products or services does not constitute a license to use such products or services or a warranty or endorsement thereof. Use of such information may require a license from a third party under the patents or other intellectual property of the third party, or a license from TI under the patents or other intellectual property of TI.

Reproduction of significant portions of TI information in TI data books or data sheets is permissible only if reproduction is without alteration and is accompanied by all associated warranties, conditions, limitations, and notices. TI is not responsible or liable for such altered documentation. Information of third parties may be subject to additional restrictions.

Resale of TI components or services with statements different from or beyond the parameters stated by TI for that component or service voids all express and any implied warranties for the associated TI component or service and is an unfair and deceptive business practice. TI is not responsible or liable for any such statements.

Buyer acknowledges and agrees that it is solely responsible for compliance with all legal, regulatory and safety-related requirements concerning its products, and any use of TI components in its applications, notwithstanding any applications-related information or support that may be provided by TI. Buyer represents and agrees that it has all the necessary expertise to create and implement safeguards which anticipate dangerous consequences of failures, monitor failures and their consequences, lessen the likelihood of failures that might cause harm and take appropriate remedial actions. Buyer will fully indemnify TI and its representatives against any damages arising out of the use of any TI components in safety-critical applications.

In some cases, TI components may be promoted specifically to facilitate safety-related applications. With such components, TI's goal is to help enable customers to design and create their own end-product solutions that meet applicable functional safety standards and requirements. Nonetheless, such components are subject to these terms.

No TI components are authorized for use in FDA Class III (or similar life-critical medical equipment) unless authorized officers of the parties have executed a special agreement specifically governing such use.

Only those TI components which TI has specifically designated as military grade or "enhanced plastic" are designed and intended for use in military/aerospace applications or environments. Buyer acknowledges and agrees that any military or aerospace use of TI components which have **not** been so designated is solely at the Buyer's risk, and that Buyer is solely responsible for compliance with all legal and regulatory requirements in connection with such use.

TI has specifically designated certain components as meeting ISO/TS16949 requirements, mainly for automotive use. In any case of use of non-designated products, TI will not be responsible for any failure to meet ISO/TS16949.

Products

Audio	www.ti.com/audio
Amplifiers	amplifier.ti.com
Data Converters	dataconverter.ti.com
DLP® Products	www.dlp.com
DSP	dsp.ti.com
Clocks and Timers	www.ti.com/clocks
Interface	interface.ti.com
Logic	logic.ti.com
Power Mgmt	power.ti.com
Microcontrollers	microcontroller.ti.com
RFID	www.ti-rfid.com
OMAP Applications Processors	www.ti.com/omap
Wireless Connectivity	www.ti.com/wirelessconnectivity

Applications

Automotive and Transportation	www.ti.com/automotive
Communications and Telecom	www.ti.com/communications
Computers and Peripherals	www.ti.com/computers
Consumer Electronics	www.ti.com/consumer-apps
Energy and Lighting	www.ti.com/energy
Industrial	www.ti.com/industrial
Medical	www.ti.com/medical
Security	www.ti.com/security
Space, Avionics and Defense	www.ti.com/space-avionics-defense
Video and Imaging	www.ti.com/video

TI E2E Community

e2e.ti.com