

Texas Instruments and/or its licensors do not warrant the accuracy or completeness of this specification or any information contained therein. Texas Instruments and/or its licensors do not warrant that this design will meet the specifications, will be suitable for your application or fit for any particular purpose, or will operate in an implementation. Texas Instruments and/or its licensors do not warrant that the design is production worthy. You should completely validate and test your design implementation to confirm the system functionality for your application.

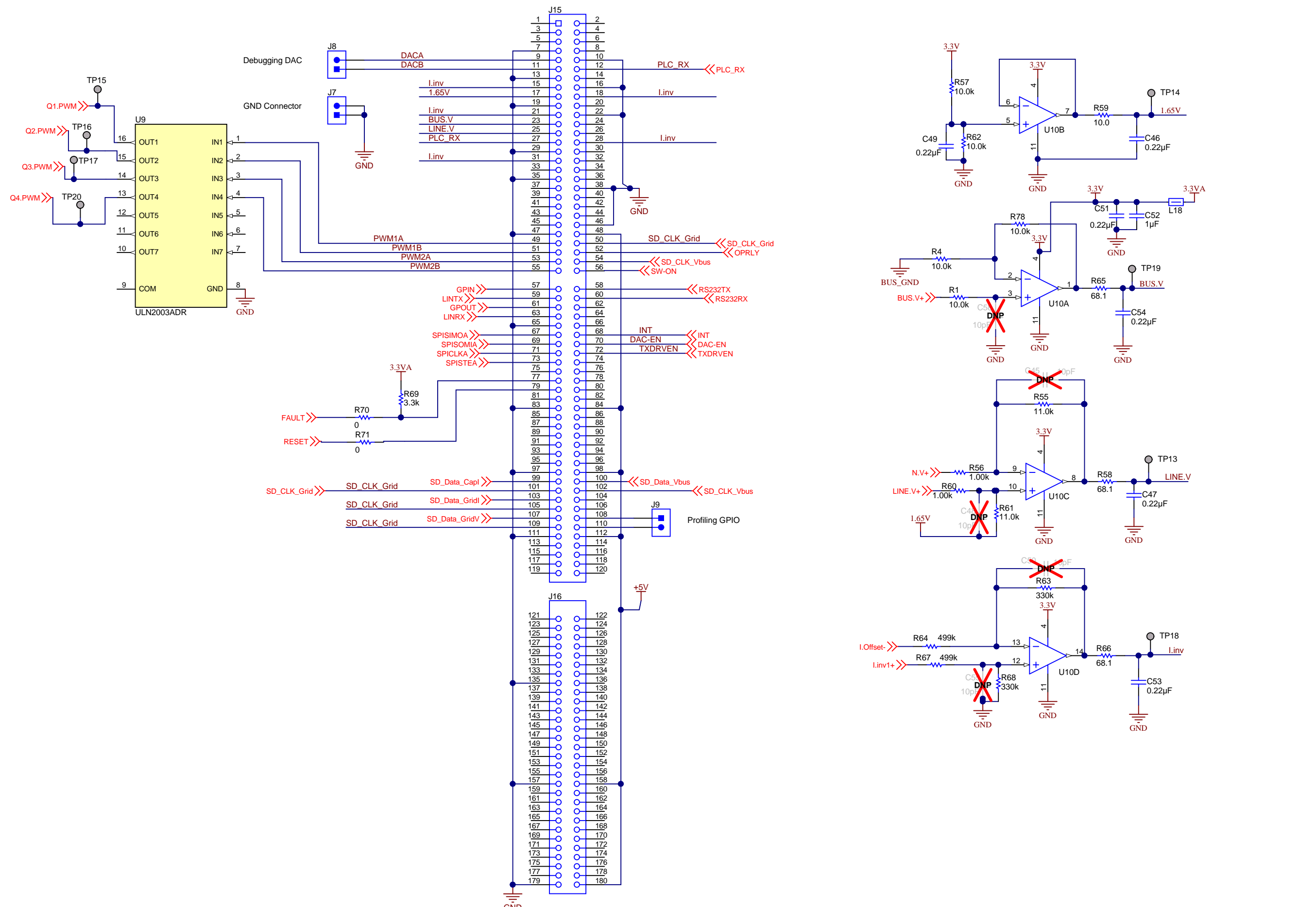

Please use HSEC180 PCB snippet.

Texas Instruments and/or its licensors do not warrant the accuracy or completeness of this specification or any information contained therein. Texas Instruments and/or its licensors do not warrant that this design will meet the specifications, will be suitable for your application or fit for any particular purpose, or will operate in an implementation. Texas Instruments and/or its licensors do not warrant that the design is production worthy. You should completely validate and test your design implementation to confirm the system functionality for your application.

Orderable: ChangeMe!	Designed for: Public Release	Mod. Date: 8/29/2016
TID #: TIDM-HV-1PH-DCAC	Project Title: TIEVM-HV-1PH-DCAC	R3
Number: MCU001	Rev: A	Sheet Title: Controller_SchDoc
SVN Rev: Version control disabled	Assembly Variant: 001	Sheet: 2 of 4
Drawn By:	File: Controller_SchDoc	Size: B
Engineer: Manish Bhardwaj	Contact: https://e2e.ti.com/support/microcontrollers/c2000	© Texas Instruments 2016

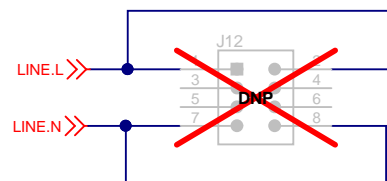
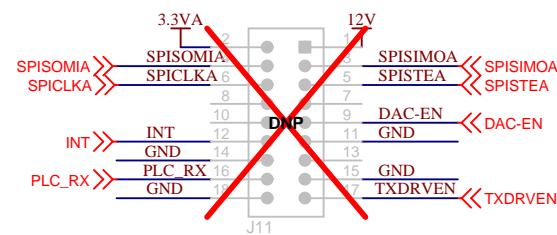
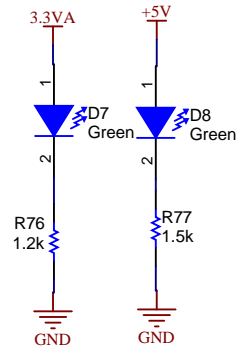
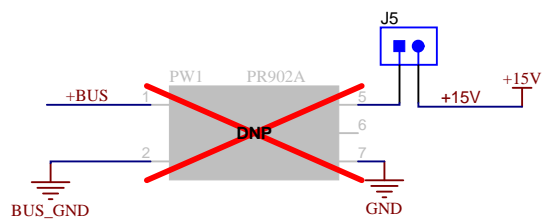
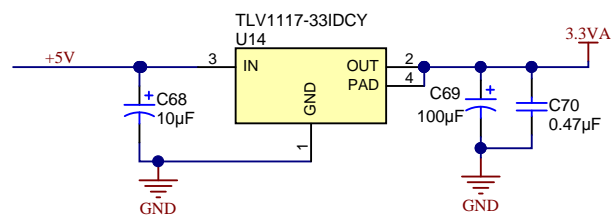
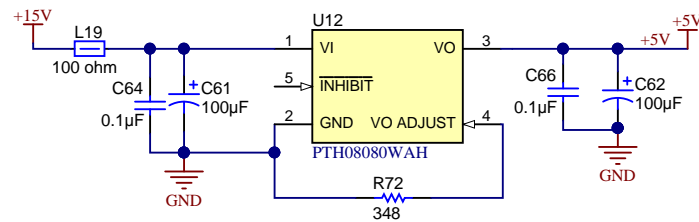
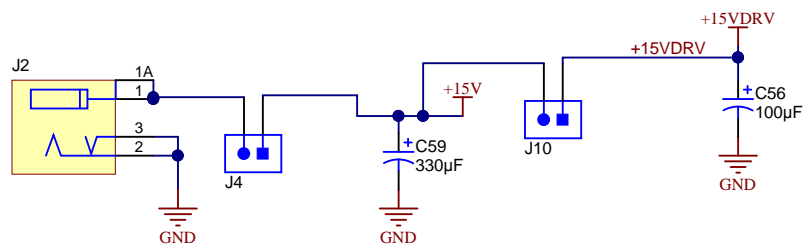

The PLC interface part

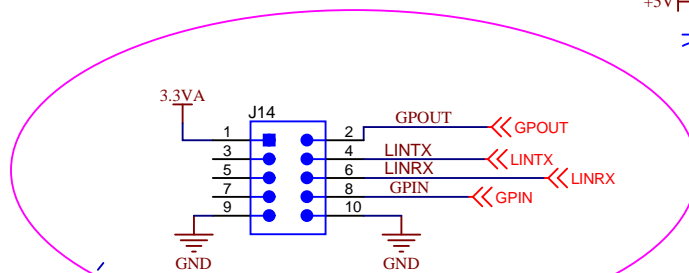
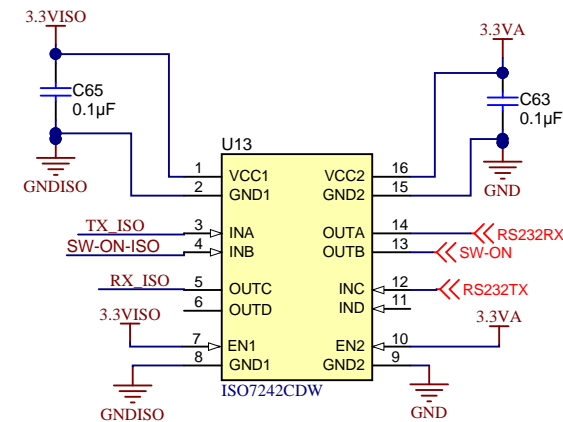
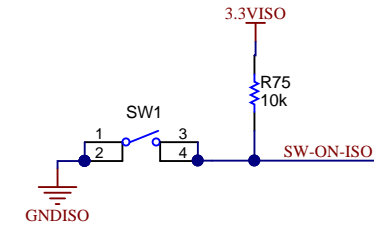
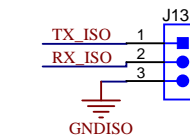
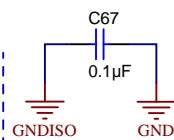
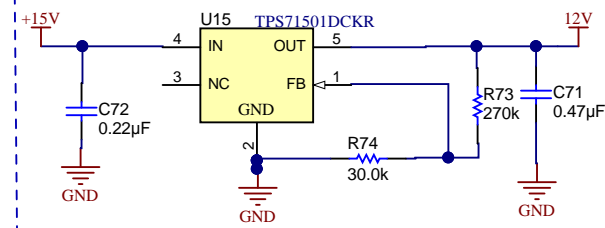

The signal interface with DC-DC board

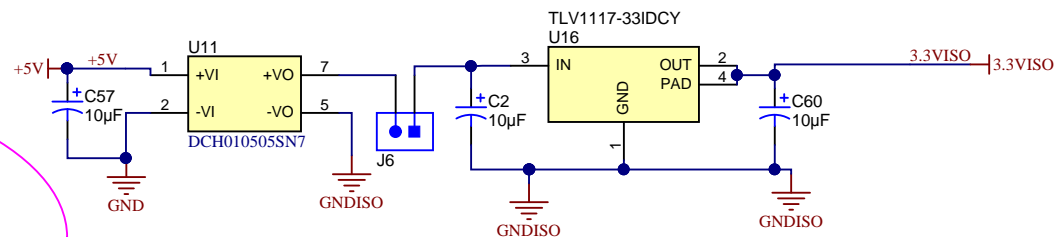

Orderable: ChangeMe!	Designed for: Public Release	Mod. Date: 8/29/2016
TID #: TIDM-HV-1PH-DCAC	Project Title: TIEVM-HV-1PH-DCAC	
Number: MCU001	Rev: A	Sheet Title: ControllerPowerMisc.SchDoc
SVN Rev: Version control disabled	Assembly Variant: 001	Sheet: 3 of 4
Drawn By:	File: ControllerPowerMisc.SchDoc	Size: B
Engineer: Manish Bhardwaj	Contact: https://e2e.ti.com/support/microcontrollers/c2000	

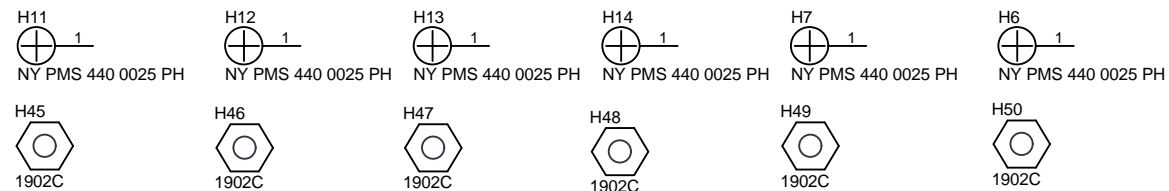

PCB Number: MCU001
PCB Rev: A

PCB LOGO
Texas Instruments
Pb-Free Symbol
FCC disclaimer

CAUTION! High Voltage Input

PCB LOGO
CAUTION! Read User Guide Before Operating
110-220Vrms, 50-60Hz

CAUTION! HOT SURFACE!

CAUTION! High Voltage

Note Variant 2 is not an orderable variant, customer must modify the board to use it in Grid Connected Inverter Mode

Variant/Label Table	
Variant	Label Text
001	TIEVM-HV-1PH-DCAC
002	TIEVM-HV-1PH-DCAC-GCI

LBL1
PCB Label
Size: 0.65" x 0.20"

CAUTION! HOT SURFACE!

ZZ1
Label Assembly Note
This Assembly Note is for PCB labels only

ZZ2
Assembly Note
These assemblies are ESD sensitive, ESD precautions shall be observed.

ZZ3
Assembly Note
These assemblies must be clean and free from flux and all contaminants. Use of no clean flux is not acceptable.

ZZ4
Assembly Note
These assemblies must comply with workmanship standards IPC-A-610 Class 2, unless otherwise specified.

ZZ5
Assembly Note
Install wire per the BOM item H40 and H41

ZZ6
Assembly Note
First Mount Q1-D1, Q2-D2, Q3-D3 & Q4-D4 across Heat sinks H1-H4, Use SIL1-8 pad, H19-H26 screw and bolt, H36-H39 lock washer and H28-H35 insulators. Use H8-10, H15-18, H27 pads for the heat sink before mounting on the board

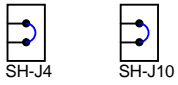
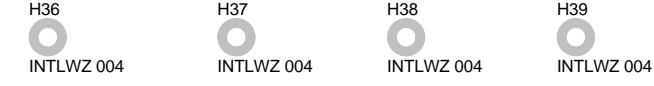
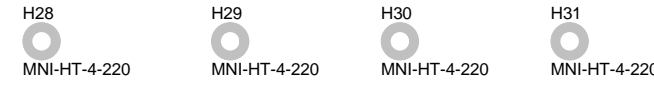
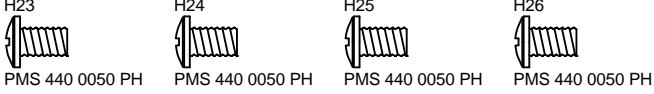
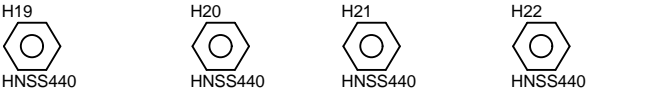

H40
MECH
18 AWG Insulated(PVC) Wire Cut 2 inches, Alpha Wire Part Number 461816 BL005

H41
MECH
18 AWG Insulated(PVC) Wire Cut 2 inches, Alpha Wire Part Number 461816 BL005

H42
MECH
83500000005

H43
MECH
83500000005

H44
MECH
83500000005

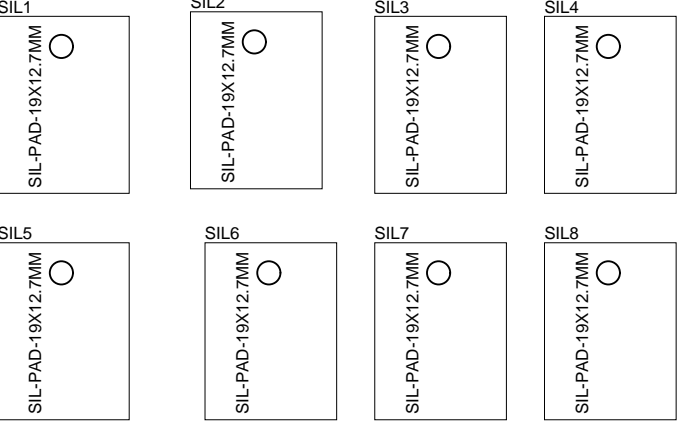
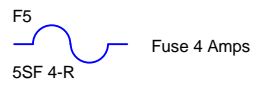
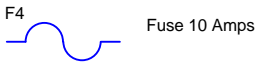

Orderable: ChangeMe!	Designed for: Public Release	Mod. Date: 9/30/2016
TID #: TIDM-HV-1PH-DCAC	Project Title: TIEVM-HV-1PH-DCAC	
Number: MCU001	Rev: A	Sheet Title: Hardware.SchDoc
SVN Rev: Version control disabled	Assembly Variant: 001	Sheet: 4 of 4
Drawn By: Manish Bhardwaj	File: Hardware.SchDoc	Size: B
Engineer: Manish Bhardwaj	Contact: https://e2e.ti.com/support/microcontrollers/c2000	

Texas Instruments and/or its licensors do not warrant the accuracy or completeness of this specification or any information contained therein. Texas Instruments and/or its licensors do not warrant that this design will meet the specifications, will be suitable for your application or fit for any particular purpose, or will operate in an implementation. Texas Instruments and/or its licensors do not warrant that the design is production worthy. You should completely validate and test your design implementation to confirm the system functionality for your application.

