

Controller Area Network Physical Layer Requirements

Steve Corrigan

ICP - Industrial Interface

ABSTRACT

The multipoint bus structure and robust protocol of the High-Speed Controller Area Network (CAN), ISO 11898:1993, is finding widespread use in building automation, process control, and other industries. This paper provides the reader with the fundamentals of CAN technology, then focuses on the physical layer requirements.

Contents

1	Introduction	2
2	Data-Flow Model.....	3
3	Basic Bus Communication Requirements	3
4	Physical Layer Requirements	4
4.1	Bus Length vs Signaling Rate	5
4.2	Cables.....	6
4.3	Shield Termination.....	6
4.4	Grounding	6
4.5	Line Terminations.....	6
4.6	Connectors	8
4.7	Filters/Chokes	9
4.8	Stub Length and Loop Delays	9
4.9	Galvanic Isolation and Total Propagation Delay	10
4.10	Physical Layer Variables (bit timing requirements)	11
4.11	Node Differential Capacitance and Spacing.....	11
4.12	Maximum Number of Nodes	14
5	Conclusion	14

List of Figures

1	The Layered ISO 11898:1993 Standard Architecture	2
2	The CAN Data-Flow Model.....	3
3	Standard CAN: 11-Bit Identifier	3
4	Extended CAN: 29-Bit Identifier	3
5	CAN Bus Traffic.....	4
6	Details of a Typical CAN Node	5
7	Unterminated and Properly Terminated Bus Signals	7
8	Standard Termination	7
9	ISO 11898 Termination – Single or Split Termination	7
10	Split Termination.....	8
11	CANopen DSUB Connector.....	8
12	5-Pin Mini-Connector (ANSI/B.93.55M-1981).....	9
13	Coupled Noise	9
14	Propagation Delay Timing Budget	10
15	Partitioning of the Bit Timing Segments.....	11
16	CAN Bus Schematic Diagram	11
17	Minimum CAN Device Spacing on a Bus With Device Capacitance and Media	

TMS320F2812 is a trademark of Texas Instruments.

Capacitance..... 13

List of Tables

1 Suggested Cable Length vs Signaling Rate 5

1 Introduction

Aside from CAN's high reliability, the main advantage of CAN over alternative networks is the low development cost. CAN controller and interface cost are as low as legacy data transmission products and are available off-the-shelf from leading semiconductor manufacturers. There are many CAN-related system development packages, hardware interface cards, and software packages that provide system designers with a wide range of design and diagnostic tools. These components provide for the development of complex control applications without having to build each node of a system network.

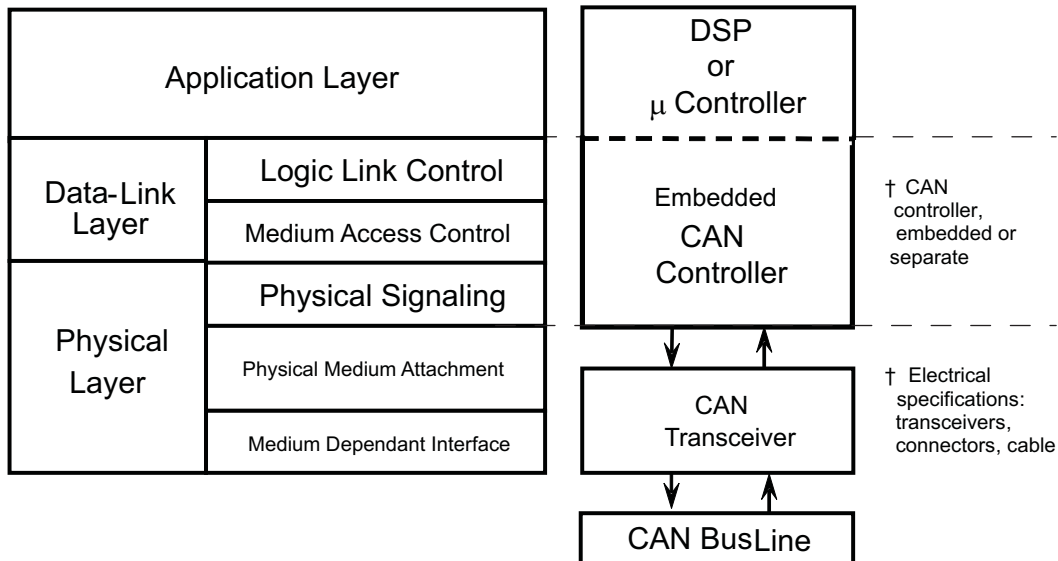

Figure 1. The Layered ISO 11898:1993 Standard Architecture

Figure 1 displays the ISO 11898 standard architecture using the bottom two layers of the OSI model, the **Data-Link Layer** and the **Physical Layer**.

The **Data-Link Layer** is responsible for transferring messages from a node to the network without errors. It handles bit stuffing and checksums, and after sending a message, waits for acknowledgment from the receivers.

The **Physical Layer** is the basic hardware required for a CAN network, i.e. the ISO 11898 electrical specifications. It converts 1's and 0's into electrical pulses leaving a node, then back again for a CAN message entering a node. Although the other layers may be implemented in software or in hardware as a chip function, the Physical Layer is always implemented in hardware.

In the **Figure 1** model, the Application Layer provides the upper-level communication functions of the OSI layered model. These functions may be implemented by a system software developer or handled by a higher-layer protocol such as the vendor-independent CANopen protocol.

2 Data-Flow Model

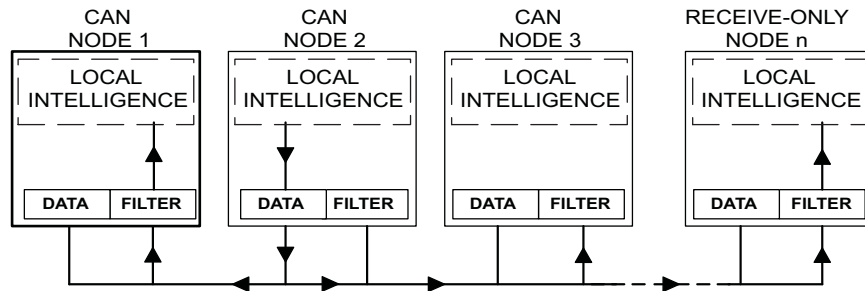

Figure 2. The CAN Data-Flow Model

Since CAN is a *broadcast* system, a transmitting node places data on the network for all nodes to access. As shown in Figure 2, only those nodes requiring updated data allow the message to pass through a filter that is set by the network designer – i.e., messages from certain nodes can pass, and all others are ignored. If this filter is not used by a system designer, much of a node's μC processing time is spent sorting through messages that are not needed.

Every message begins with the 11-bit or 29-bit identifier shown in Figure 3 and Figure 4, that a system designer can use to identify the content of a message, such as temperature or shaft position. In this way, a designer can prioritize messages. For instance, an automotive message with brake information is given a higher priority identifier than a turn-signal identifier. This priority is discussed in the next section.

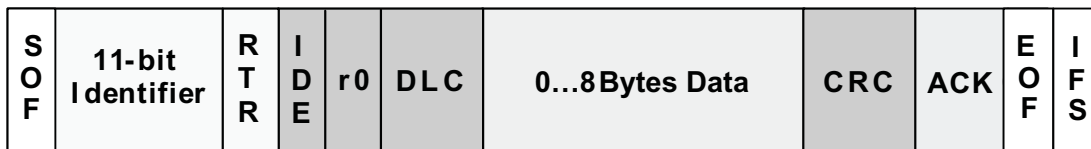

Figure 3. Standard CAN: 11-Bit Identifier

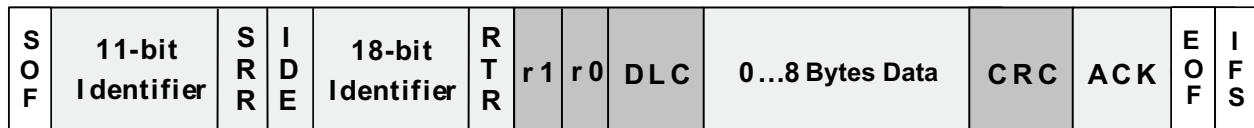

Figure 4. Extended CAN: 29-Bit Identifier

CAN's multiple reception provides for the concept of modular electronics and the synchronization of distributed control processes: data needed by several nodes is broadcast on the network in such a way that it becomes unnecessary for a node to know origin of the data. This allows for easy servicing and upgrading networks since data transmission is not dependant upon the availability of a specific type of node.

System flexibility is achieved as a result of the content-oriented addressing scheme. This enables the reconfiguration of an existing CAN network without making any hardware or software modifications. A new node may be added that only receives operating data from the other transmitting nodes in a system, and never sends data.

3 Basic Bus Communication Requirements

Note that a minimum of two nodes must be used to initialize communication on a CAN bus. Since a transmitted message must be acknowledged in the ACK bit by a receiver, the transmitting controller will send out an error flag if the message is not properly ACKed.

All nodes on a bus participate in each bit – *as it is being written*. The device sending a message is also receiving that message itself – checking each bit as it is written. In this way, the second node *fills in* the ACK bit while the bit is still being transmitted by the first node. This is why it takes two nodes to complete a message transmission. This function is best displayed during the arbitration shown in Figure 5. The nodes of Figure 5 could theoretically be sending messages from a sensing circuit and motor controller.

An actual application may include a temperature sensor sending out a temperature update that is used to adjust the motor speed of a fan. If a pressure sensor node wants to send a message at the same time, the arbitration in Figure 5 assures that the message will be sent. On the left side of the scope Node A finishes sending its message as Nodes B and C fill in the ACK bit indicating that a message is received without errors. After the mandatory inter-frame space between messages, Nodes B and C then begin arbitration – Node C wins the arbitration with the final dominant bit and sends its message. Nodes A and B then ACK C's message. Node B then continues on with its uncontested arbitration and message which is ACKed by Nodes A and C.

Note that if the ACK bit is missing, the transmitting controller will generate its own error flag. If a message is not ACKed, an error is generated with each occurrence until the controller reaches an error limit that is internally set by the CAN protocol. The controller places itself in a *bus-off* state when this internal limit is reached. This is a protocol controller function that prevents a single node from blocking all communication on a bus.

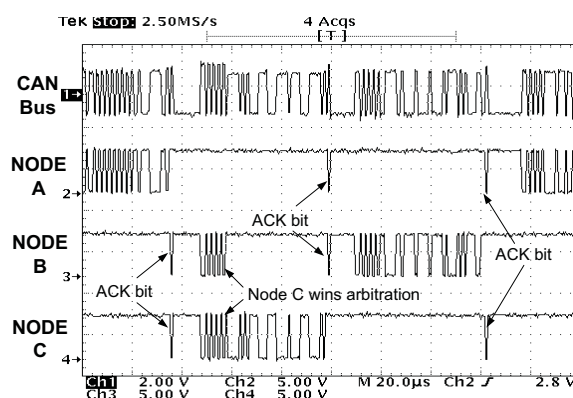

Figure 5. CAN Bus Traffic

4 Physical Layer Requirements

The data link and physical signaling layers of Figure 1, which are normally transparent to a system operator, are included in any controller that implements the CAN protocol such as the Texas Instruments TMS320F2812™ 3.3-V DSP with integrated CAN controller. Connection to the physical medium (the bus) is then implemented through a line transceiver such as TI's SN65HVD233 3.3-V CAN transceiver to form a system node shown in Figure 6.

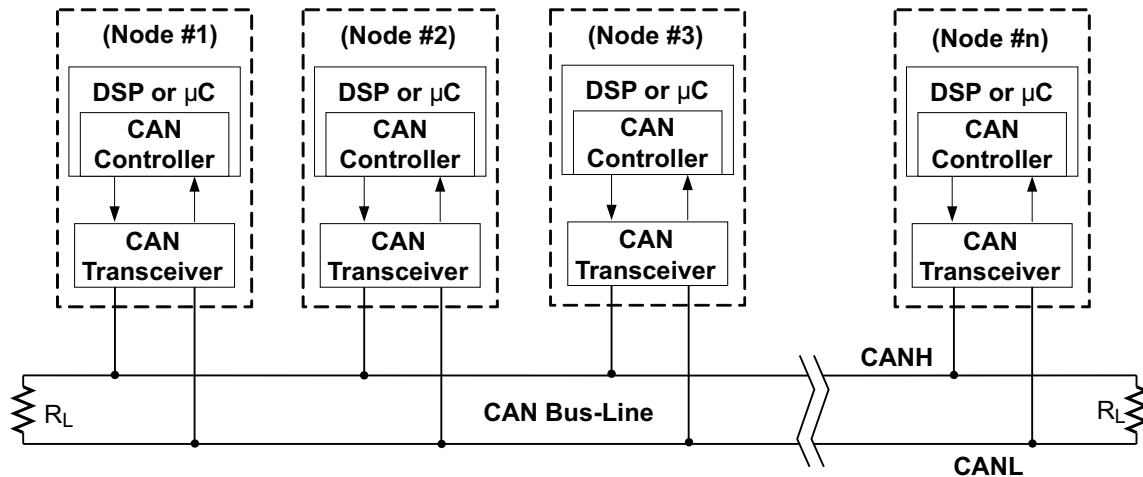

Figure 6. Details of a Typical CAN Node

The High-Speed ISO 11898 Standard specifications are given for a maximum signaling rate of 1 Mbps with a bus length of 40 m and a maximum of 30 nodes. It also recommends a maximum un-terminated stub length of 0.3 m. The cable is specified to be a shielded or unshielded twisted-pair with a 120-Ω characteristic impedance (Z_0). The Standard defines a single line of twisted-pair cable with the network topology as shown in Figure 6. It is terminated at both ends with 120-Ω resistors, which match the characteristic impedance of the line to prevent signal reflections. According to ISO 11898, placing R_L on a node should be avoided since the bus lines lose termination if the node is disconnected from the bus.

4.1 Bus Length vs Signaling Rate

Table 1. Suggested Cable Length vs Signaling Rate

Bus Length (m)	Signaling Rate (Mbps)
40	1
100	0.5
200	0.25
500	0.10
1000	0.05

Basically, the maximum bus length is determined by, or rather is a trade-off with the selected signaling rate as listed in Table 1.

A signaling rate decreases as transmission distance increases. While steady-state losses may become a factor at the longest transmission distances, the major factors limiting signaling rate as distance is increased are time varying. Cable bandwidth limitations, which degrade the signal transition time and introduce inter-symbol interference (ISI), are primary factors reducing the achievable signaling rate when transmission distance is increased.

For a CAN bus, the signaling rate is also determined from the total system delay – down and back between the two most distant nodes of a system and the sum of the delays into and out of the nodes on a bus with the typical 5ns/m prop delay of a twisted-pair cable. Also, consideration must be given the signal amplitude loss due to resistance of the cable and the input resistance of the transceivers. Under strict analysis, skin effects, proximity to other circuitry, dielectric loss, and radiation loss effects all act to influence the primary line parameters and degrade the signal.

A conservative rule of thumb for bus lengths over 100 m is derived from the product of the signaling rate in Mbps and the bus length in meters, which should be less than or equal to 50.

$$\text{Signaling Rate (Mbps)} \times \text{Bus Length (m)} \leq 50$$

If a 1000 m bus is required by an application, then by this approximation a 50 kbps signaling rate may safely be used. Lab experiments show that an actual safe signaling rate with 1000 m of 120- Ω characteristic impedance twisted-pair cable is indeed approximately 50 kbps. By providing this extra margin of safety, a lot of system variation can still take place without disruptions in communication.

A long cable length with a higher number of nodes than the Standard's recommended 30 nodes may require the use of higher cable quality, a CAN bus repeater, and tighter operating tolerances such as a 5% voltage supply regulation. In practice, however, almost any type of cable works to a certain degree, even a cheap phone line for short distances.

4.2 Cables

Although unshielded 120- Ω cable is used in many applications, data transmission circuits employing CAN transceivers are used for jobs requiring a rugged interconnection with a wide common-mode voltage range. Therefore, shielded cable such as Belden Cable 3105A is recommended in these electronically harsh environments. Shielded cable and the Standard's -2 V to 7 V common-mode range of tolerable ground off-set, help to ensure data integrity. Note that the HVD1050 CAN transceiver has an extended common-mode range of -12 V to 12 V.

While prefabricated cables for CAN applications are more expensive, they are more easily installed and verified, and may, therefore, reduce overall installation cost and time-to-market.

4.3 Shield Termination

If a shield must be used, it is recommended that a short pig-tail be crimped to the shield end at each connector and then brought through a separate connector pin to a ground pin located as close to the connector as possible. Note that the network should be grounded at a single point at the source location. This prevents parasitic currents from flowing in the shield between ground connections.

If individual shielding of the signal pairs is used, use the same terminating technique as for the overall shield.

4.4 Grounding

There should be only one path for return current between the host and receiving nodes. This follows the same discussion in the shielding section. If a network is grounded in more than one location, parasitic current will flow. By grounding a network only at the source, potentially hazardous ground loops are avoided. The use of digital isolators such as the ISO721 ([SLLS629](#)) is recommended if it becomes necessary to connect the grounds of different sources.

Unused pins in connectors as well as unused wires in cables should be single-point grounded at the connector. Unused wires should be grounded at alternate ends to nearby ground pins.

4.5 Line Terminations

The 120- Ω characteristic impedance twisted-pair cable is terminated with an impedance of the same value to minimized reflected waves that occur from miss-matched impedances. [Figure 7](#) is an example of the reflected waves that build up on a signal when termination is removed.

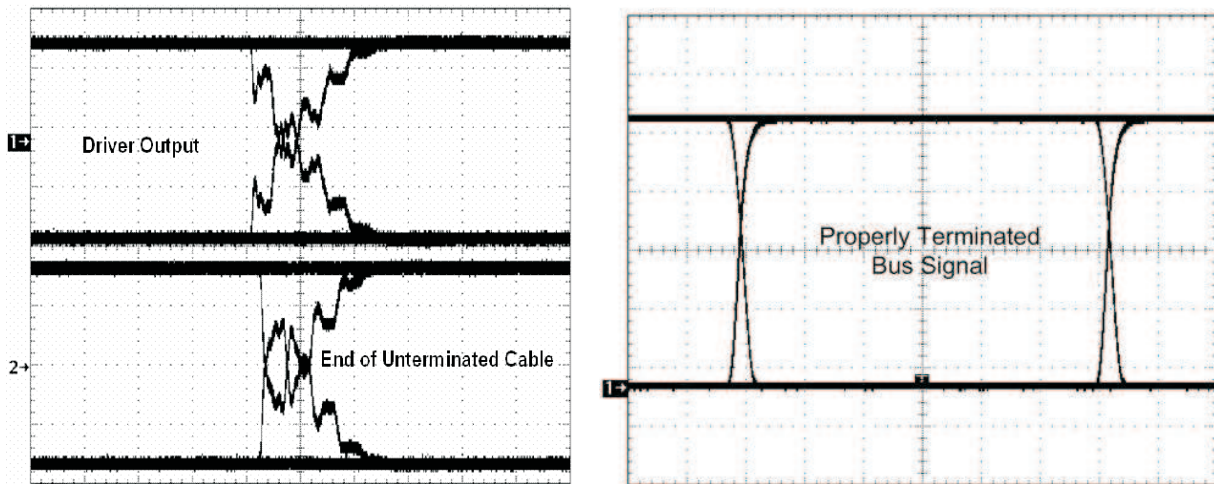

Figure 7. Unterminated and Properly Terminated Bus Signals

Each step in the signal is a reflected wave adding to the original signal across 1 meter of unterminated twisted-pair cable. The length of each of the steps is approximately 10 ns, the typical down-and-back propagation delay per meter of cable. The signal continues to build in magnitude until the supply voltage is reached.

Two different termination models are recommended for high-speed CAN as shown in [Figure 8](#) and [Figure 9](#). The traditional $120\ \Omega$ R_L on each end of the bus, or the split termination using two $60\ \Omega$, $R_L/2$ resistors and a coupling capacitor C_L . These are often used to filter high frequency components on the bus.

4.5.1 Standard Termination

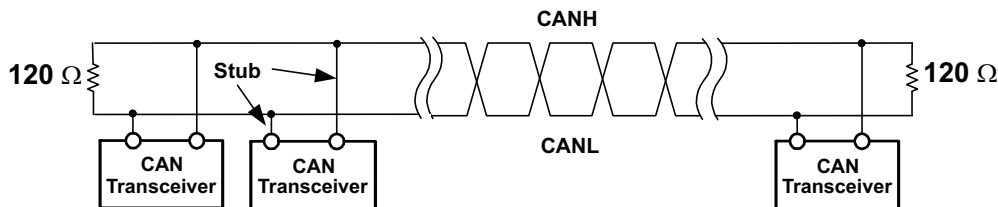

Figure 8. Standard Termination

Care must be taken to allow for short-circuits to power supplies when selecting appropriately rated termination resistors. While $1/4\ W$ 5% tolerance resistors are generally acceptable, a bus-line short-circuit to a 24 V supply line would generate a transceiver's I_{OS} short-circuit output current multiplied by the supply voltage. The $1/4\ W$ resistor would blow up in this circumstance.

4.5.2 Split Termination

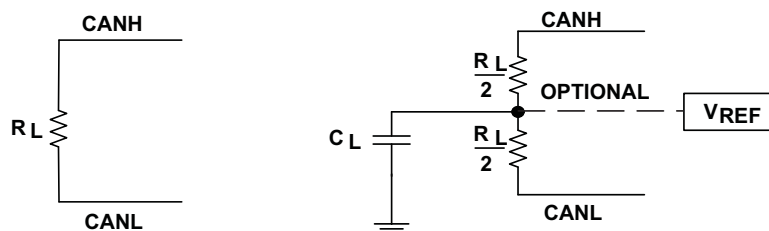

Figure 9. ISO 11898 Termination – Single or Split Termination

Note that transceivers such as the SN65HVD1050 have a V_{ref} or V_{split} pin shown in Figure 9 that is specifically designed to stabilize the common-mode bus voltage during communication (this also helps reduce radiated emissions). The HVD1050's V_{ref} pin has the same wide common-mode operating range and ESD protection as the bus pins.

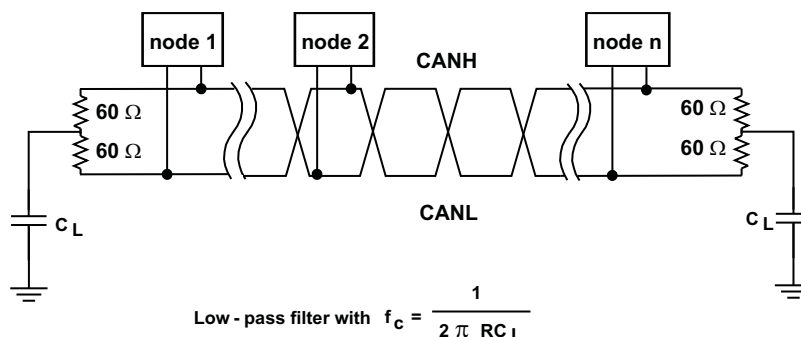

Figure 10. Split Termination

Unwanted high frequency noise is filtered from bus lines with the split termination of Figure 10. This is accomplished with coupling capacitor between two $\sim 60 \Omega \pm 1\%$ termination resistors to couple high frequency noise to a solid ground potential. Care must be taken to match the two resistors carefully so as to not reduce the effective immunity. This technique improves the electromagnetic compatibility of a network. A typical value of C_L for a high-speed CAN is 4.7 nF, which generates a 3 dB point at 1.1 Mbps. This, of course is a signaling rate dependant value.

4.6 Connectors

Connectors, while not specified by the Standard, should have a characteristic impedance matching that of the bus line and terminators, and it should not affect standard operating parameters such as the minimum V_{OD} .

The higher layer protocols such as CANopen and DeviceNet define the specific hardware required for implementation, including bus wire and connectors. Recommended products may be found on organization web-sites such as the CiA's CAN-cia.com which list connector and pin-out specifications for use in CANopen applications. These include the 9-pin DSUB shown in Figure 11, Multipole, RJ10, RJ45, M12, the 5-pin mini-style in Figure 12 and more micro-style connectors in the CiA specification document DR 303-1, V1-3.

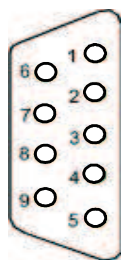

Pin		Description
1	Reserved	
2	CANL	CANL bus pin
3	V+	Optional 3.3-V or 5-V power supply for transceivers and digital isolators if required
4	Reserved	
5	CAN_SHLD	Optional shield
6	V-	Ground return path/ 0V
7	CANH	CANH bus pin
8	Reserved	
9	V+	Optional 3.3-V or 5-V power supply for transceivers and digital isolators if required

Figure 11. CANopen DSUB Connector

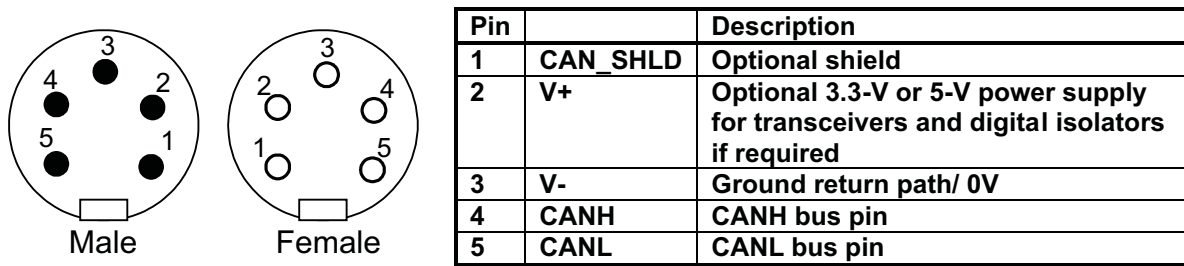

Figure 12. 5-Pin Mini-Connector (ANSI/B.93.55M-1981)

4.7 Filters/Chokes

Bus-lines and a ground plane can form a loop for inductively coupled noise signals and depending upon the topology, a bus can easily become an antenna for local noise.

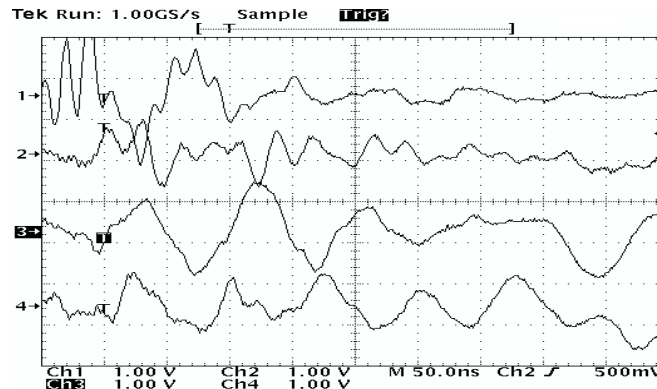

Figure 13. Coupled Noise

The cables used in Figure 13 are different lengths of unshielded twisted-pair 24 AWG copper wire and the figure clearly displays the inducted noise from nearby florescent lighting. Properly filtered, these would be four noise-free straight lines. Induced voltages of 10 V or more are commonly found on industrial buses.

Chokes such as the ZJYS81RS-2PL51(T)-G01 have been developed by TDK specifically to address this problem in CAN applications.

4.8 Stub Length and Loop Delays

Since stub-lines are unterminated, signal reflections can develop in a stub that drive signal levels back and forth across a receiver's input thresholds, creating errors. Bit-sampling occurs near the end of a bit, so it is mandatory that all signal reflections in a CAN stub-line be attenuated before or during the propagation delay segment in Figure 15 to provide an adequate margin of safety.

To minimized reflections, stub-line length should not exceed one-third (1/3) of the line's critical length. Beyond this stub-length, many variables come into play since the stub is no longer considered to be a lumped parameter. This is the maximum length that a stub remains invisible to a transmission line.

The critical length of a bus line occurs at the point where the down-and-back propagation delay ($t_{prop(total)}$) of a signal through a line equals the transition time(t_t) of a signal (the greater of the rise or fall times).

$$\text{Network Critical Length} = t_t = t_{prop(total)}$$

Therefore, a typical CAN driver may have a 50 ns transition time, and when considering a typical twisted-pair transmission line prop delay of 5 ns/m, the down-and-back delay for one meter becomes 10ns/m. The critical length becomes 5 m (50 ns / 10ns/m = 5 m), and the max un-terminated stub length for the network is 1/3rd of the critical length, or 5/3 m (1.67 m).

When critical length is taken into consideration, driver slew-rate control becomes a valuable design asset. The Standard recommends a maximum un-terminated stub length of 0.3 m with a 1 Mbps signaling rate, but with slew rate control, reduced signaling rate, and careful design, longer stub lengths are easily obtained.

For example, if a 10 kΩ resistor is applied for slope-control at the Rs pin (pin 8) of the HVD230 CAN transceiver, a 160 ns driver transition time increases the maximum stub length to 16/3 m or 5 1/3 meters.

4.9 Galvanic Isolation and Total Propagation Delay

If galvanic isolation is required on a network, it is necessary to compensate for signal propagation delays on the bus line as well as through the electronic interface circuits of the bus nodes. The sum of the propagation delay times of controllers, galvanic isolators, transceivers and bus lines has to be a small fraction of the time of a single bit. A prop delay total must be calculated and depends on the selected components: CAN controller (50 ns to 75 ns), digital isolator (17 ns for a TI isolator and up to 140 ns for an optocoupler), transceiver (100 ns to 250 ns), and cable (about 5 ns/m).

These delays have to be carefully considered because a round trip has to be made back from the most distant CAN controller on the bus while the bit is still being written by the sender. Remember that each node actively participates in the writing of every bit, and then actively fills in the ACK slot if it is not the source of the message.

A typical propagation delay budget is comprised of : a transmitted bit from Figure 14's Node #1's μC – isolator delay, driver delay, 10 m bus delay, receiver delay, isolator delay, controller delay, isolator delay, driver delay, bus delay, receiver delay, isolator delay – receive it back to #1's μC. The total is calculated using 50 ns for the controller, 17 ns for the TI isolator, 100 ns for transceivers driver and 100 ns for the transceiver's receiver, then 5 ns per meter for the cable.

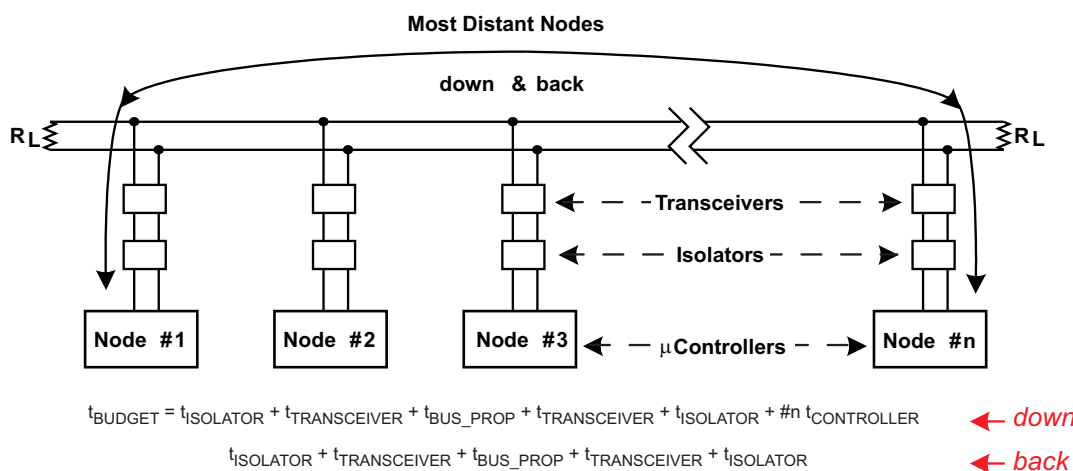

Figure 14. Propagation Delay Timing Budget

Therefore, in Figure 14, the total prop delay is: 1st transmit bit from μC – isolator delay (17 ns), driver delay (100 ns), bus delay [10 m (5 ns/m)], receiver delay (100 ns), isolator delay (17 ns), controller delay (50 ns), isolator delay (17 ns), driver delay (100 ns), bus delay [10 m (5 ns/m)], receiver delay (100 ns), isolator delay (17 ns) = 618 ns. Once these delays are totaled, allowances for oscillator variations, operating variables, etc must be accounted for before a signaling rate is selected, since the incident wave of the first bit must be back to the sending node long before the bit is sampled as a dominant or recessive bit.

4.10 Physical Layer Variables (bit timing requirements)

Each CAN bit is divided into the four segments in Figure 15, with a sample point typically located at the 75% point of a bit width. The first segment, the synchronization segment (SYNC_SEG), is the time that a recessive to dominant transition is expected to occur. All the nodes on a bus synchronize on rising edges. The second segment, the propagation time segment (PROP_SEG), is designed to compensate for the physical delay times of the network. The third and fourth segments, both phase buffer segments (PHASE_SEG1 and PHASE_SEG2), are used for resynchronization. The bit value is sampled immediately following PHASE_SEG1.

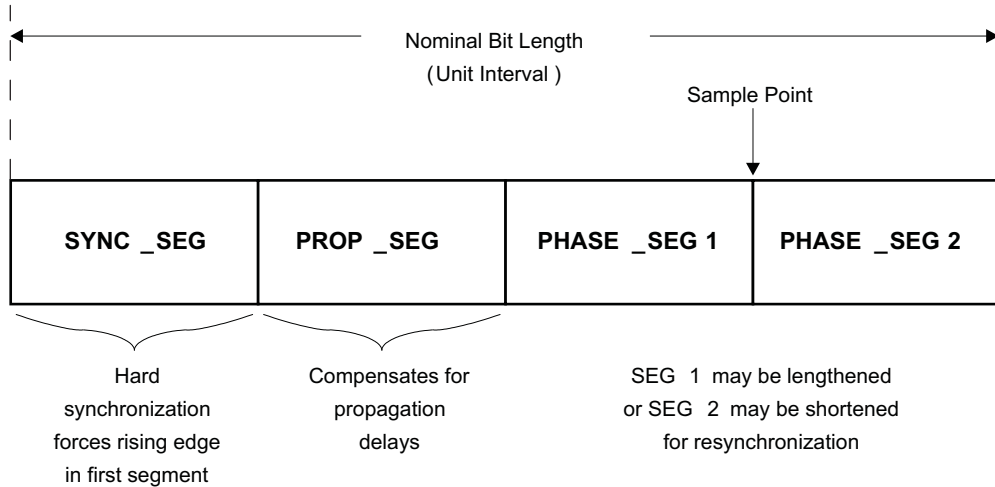

Figure 15. Partitioning of the Bit Timing Segments

4.11 Node Differential Capacitance and Spacing

The ISO-11898 CAN bus of Figure 16 is a distributed parameter circuit whose electrical characteristics and responses are primarily defined by the distributed inductance and capacitance⁽¹⁾ along the physical media. The media is defined here as the interconnecting cable or conducting paths, connectors, terminators, and CAN devices added along the bus. The following analysis derives a guideline for the amount of capacitance that can be added and its spacing on the bus while maintaining signal integrity.

For a good approximation, the characteristic transmission line impedance seen in any cut point in the

unloaded CAN bus is defined by $Z = \sqrt{L/C}$, where L is the inductance per unit length and C is the capacitance per unit length. As capacitance is added to the bus with unequal spacing between nodes, in the form of devices and their interconnection, the bus impedance is lowered to Z' and when the bus impedance is lowered, an impedance mismatch occurs between an unloaded section and a loaded section of the bus.

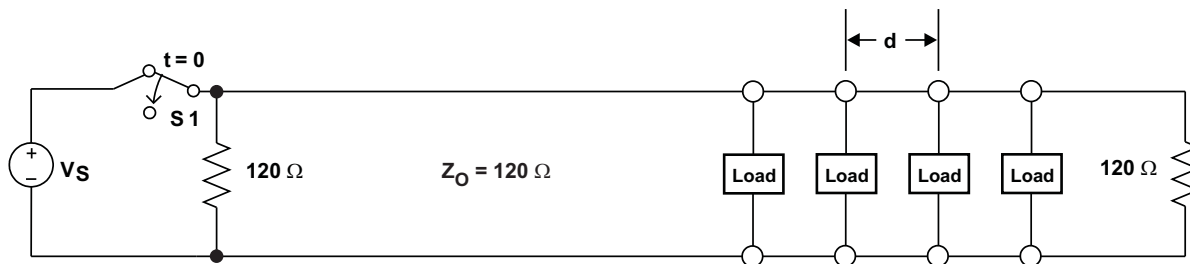

Figure 16. CAN Bus Schematic Diagram

⁽¹⁾ Capacitance here is defined as differential, which is approximately one-half of the single-ended capacitance.

The resulting worst-case problem occurs during a dominant-to-recessive transition in arbitration or an ACK bit. When S1 switches at time zero from a dominant state to a recessive steady state, the CAN driver differential output voltage, V_S , moves from the standard maximum 3 V signal on the bus to a 0 V recessive state. As this signal wave propagates down the line and arrives at the loaded section of the bus in Figure 14, the mismatch in impedance reflects voltage back towards the source.

With fast transfer rates and electrically long⁽²⁾ media, it becomes essential to achieve a valid input voltage level on the first signal transition from an output driver anywhere on the bus. This is called incident-wave switching. If incident-wave conditions are not achieved, reflected-wave switching must be used. Reflected-wave switching depends upon reflected energy occurring some time after the first transition arrives to achieve a valid logic voltage level.

As the input signal wave arrives at this mismatch in impedance, an attenuation (or amplification) of the signal will occur. The signal voltage at an impedance mismatch is $V_{L1} = V_{L0} + V_{J1} + V_{R1}$, where V_{L0} is the initial dominant differential voltage, V_{J1} is the input signal recessive differential voltage, and V_{R1} is the reflected differential voltage.

The voltage reflected back from the mismatch is $V_{R1} = \rho_L \times V_{J1}$ where, $\rho_L = \frac{Z' - Z}{Z' + Z}$ and is the coefficient of reflection commonly used in transmission line analysis. The voltage equation can now be written as $V_{L1} = V_{L0} + V_{J1} + \rho_L \times V_{J1}$.

Assuming the bus is terminated at both ends with the nominal media impedance, a CAN driver creates a high-to-low differential voltage change from the standard maximum V_{L0} of 3 V to 0 V, or a V_{J1} of -3 V. The signal voltage at the load, V_{L1} , must go below the receiver recessive bit input voltage threshold of 0.5 V.

In equation form,

$$0.5 > 3 + (-3) + \rho_L \times (-3)$$

$$\rho_L > \frac{0.5}{-3} = -0.167 \quad (1)$$

Now, solving for Z'

$$\rho_L = \frac{Z' - Z_0}{Z' + Z_0} > -0.167$$

$$Z' - Z_0 > -0.167(Z' + Z_0)$$

$$Z' (1 + 0.167) > Z_0(1 - 0.167)$$

$$Z' > 0.71 Z_0 \quad (2)$$

If the loaded bus impedance is no less than 0.71 Z_0 , the minimum threshold level should be achieved on the incident wave under all allowed cases.

What bus configuration rules should be used to keep the loaded bus impedance above 0.71 Z_0 ?

In the derivation of the minimum loaded-bus impedance, the addition of devices, and their capacitance is treated as a distributed model. As such, the loaded-bus impedance can be approximated by

$Z' = \sqrt{\frac{L}{C+C'}}$ where C' is the added capacitance per unit length. If the distributed inductance and capacitance of the media were known, Z' could be calculated directly. Unfortunately, these are not commonly specified by manufacturers. However, the characteristic impedance Z_0 and the capacitance per

unit length, C , is generally specified. With these, L can be solved from the relationship $Z_0 = \sqrt{\frac{L}{C}}$ as $L = Z_0^2 C$. Substituting into the equation for Z' and simplifying,

$$Z' = \sqrt{\frac{Z_0^2 C}{C+C'}} = Z_0 \sqrt{\frac{C}{C+C'}} \quad (3)$$

C' is the distributed device capacitance, C_L , divided by the distance, d , between devices or $C' = C_L/d$. Substituting this into the equation and solving for d ,

⁽²⁾ Electrically long is defined here as $\tau > (t_{10\%-90\%})/3$, where τ is the one-way time delay across the bus and $(t_{10\%-90\%})$, is the 10% to 90% transition time of the fastest driver output signal.

$$\begin{aligned}
 Z' &= Z_0 \sqrt{\frac{C}{C + C_L/d}} \\
 \left(\frac{Z'}{Z_0}\right)^2 &= \frac{C}{C + C_L/d} \\
 C \left(\frac{Z_0}{Z'}\right)^2 &= C + C_L/d \\
 d &= \frac{C_L}{C \left(\left(\frac{Z_0}{Z'}\right)^2 - 1\right)}
 \end{aligned}
 \tag{4}$$

Now substituting our minimum Z' of $0.71 Z_0$ gives,

$$\begin{aligned}
 d &> \frac{C_L}{C \left(\left(\frac{Z_0}{0.71 Z_0}\right)^2 - 1\right)} \text{ meters (if } C \text{ is pF/m) or feet (if } C \text{ is pF/ft).} \\
 d &> \frac{C_L}{0.98C}
 \end{aligned}
 \tag{5}$$

This is a relationship for the minimum device spacing on a bus as a function of the distributed media capacitance and lumped load capacitance. Figure 17 displays this relationship graphically.

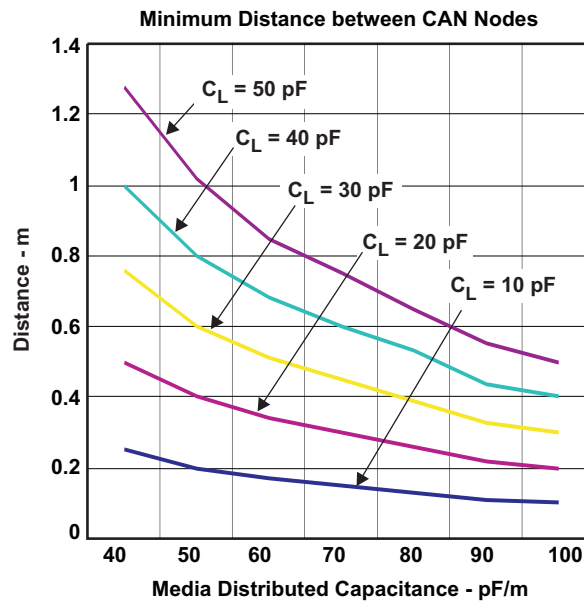

Figure 17. Minimum CAN Device Spacing on a Bus With Device Capacitance and Media Capacitance

Load capacitance, C_L , includes contributions from the CAN bus pins, connector contacts, printed-circuit board traces, protection devices, and any other physical connections as long as the distance from the bus to the transceiver is electrically short.

The typical 5-V CAN transceiver, such as the SN65HVD251, has a capacitance of 10 pF. The three-volt supplied transceivers, such as the SN65HVD230, have a bit more capacitance than the 5-V device with 16 pF. Board traces add about 0.5 pF/cm to 0.8 pF/cm depending upon their construction. Media distributed capacitance ranges from 40 pF/m for low-capacitance unshielded-twisted-pair cable to 70 pF/m for backplanes. Note that connector and suppression device capacitance can vary widely.

This derivation gives guidelines for spacing CAN nodes along a bus segment based upon the lumped load capacitance. The method is equally applicable to other multipoint or multidrop buses, such as RS-485, RS-422, or M-LVDS, with appropriate adaptation of the parameter values.

4.12 Maximum Number of Nodes

In practice, up to 64 nodes may be connected to a DeviceNet bus, 127 on a CANopen bus and up to 255 nodes may be connected together on a CANkingdom bus. When more than the standard 30 nodes are used on a bus, it is recommended that a transceiver with a high bus-input impedance, such as an HVD230 or HVD251 be used.

A problem may develop when too many transceivers source or sink current onto or from the bus. When a device begins to transmit a message, it has to sink or source all of the leakage current on the bus, plus drive the standard signal voltage levels across the termination resistance. If the current demand is too great, the device may be driven into thermal shut-down or destroyed.

To prevent transceiver damage, the voltage difference between reference grounds of the nodes on a bus should be held to a minimum. This is the common-mode voltage across the entire system and although many transceivers such as the HVD251 are designed to operate over an extended common-mode range, the cumulative current demand of too many devices at a common-mode voltage extreme may jeopardize network security. To enhance this common-mode security, most higher layer protocols like DeviceNet specify that power and ground wires be carried along with the signaling pair of wires. Several cable companies have developed 4-wire bundled cables specifically for these applications.

5 Conclusion

CAN is an open collector technology – the protocol could not work otherwise. This means that the recessive state of a CAN transceiver is not actively driven. The termination resistors together with transceiver input capacitance and cable capacitance create an RC time-constant discharge when an actively-driven dominant bit on the bus transitions to an un-driven recessive bit. For signaling rates greater than CAN's 1Mbps, a technology that actively drives the bus in both states such as RS-485 is required to facilitate the bus transitions required for high-speed signaling rates.

IMPORTANT NOTICE

Texas Instruments Incorporated and its subsidiaries (TI) reserve the right to make corrections, modifications, enhancements, improvements, and other changes to its products and services at any time and to discontinue any product or service without notice. Customers should obtain the latest relevant information before placing orders and should verify that such information is current and complete. All products are sold subject to TI's terms and conditions of sale supplied at the time of order acknowledgment.

TI warrants performance of its hardware products to the specifications applicable at the time of sale in accordance with TI's standard warranty. Testing and other quality control techniques are used to the extent TI deems necessary to support this warranty. Except where mandated by government requirements, testing of all parameters of each product is not necessarily performed.

TI assumes no liability for applications assistance or customer product design. Customers are responsible for their products and applications using TI components. To minimize the risks associated with customer products and applications, customers should provide adequate design and operating safeguards.

TI does not warrant or represent that any license, either express or implied, is granted under any TI patent right, copyright, mask work right, or other TI intellectual property right relating to any combination, machine, or process in which TI products or services are used. Information published by TI regarding third-party products or services does not constitute a license from TI to use such products or services or a warranty or endorsement thereof. Use of such information may require a license from a third party under the patents or other intellectual property of the third party, or a license from TI under the patents or other intellectual property of TI.

Reproduction of TI information in TI data books or data sheets is permissible only if reproduction is without alteration and is accompanied by all associated warranties, conditions, limitations, and notices. Reproduction of this information with alteration is an unfair and deceptive business practice. TI is not responsible or liable for such altered documentation. Information of third parties may be subject to additional restrictions.

Resale of TI products or services with statements different from or beyond the parameters stated by TI for that product or service voids all express and any implied warranties for the associated TI product or service and is an unfair and deceptive business practice. TI is not responsible or liable for any such statements.

TI products are not authorized for use in safety-critical applications (such as life support) where a failure of the TI product would reasonably be expected to cause severe personal injury or death, unless officers of the parties have executed an agreement specifically governing such use. Buyers represent that they have all necessary expertise in the safety and regulatory ramifications of their applications, and acknowledge and agree that they are solely responsible for all legal, regulatory and safety-related requirements concerning their products and any use of TI products in such safety-critical applications, notwithstanding any applications-related information or support that may be provided by TI. Further, Buyers must fully indemnify TI and its representatives against any damages arising out of the use of TI products in such safety-critical applications.

TI products are neither designed nor intended for use in military/aerospace applications or environments unless the TI products are specifically designated by TI as military-grade or "enhanced plastic." Only products designated by TI as military-grade meet military specifications. Buyers acknowledge and agree that any such use of TI products which TI has not designated as military-grade is solely at the Buyer's risk, and that they are solely responsible for compliance with all legal and regulatory requirements in connection with such use.

TI products are neither designed nor intended for use in automotive applications or environments unless the specific TI products are designated by TI as compliant with ISO/TS 16949 requirements. Buyers acknowledge and agree that, if they use any non-designated products in automotive applications, TI will not be responsible for any failure to meet such requirements.

Following are URLs where you can obtain information on other Texas Instruments products and application solutions:

Products

Amplifiers	amplifier.ti.com
Data Converters	dataconverter.ti.com
DSP	dsp.ti.com
Clocks and Timers	www.ti.com/clocks
Interface	interface.ti.com
Logic	logic.ti.com
Power Mgmt	power.ti.com
Microcontrollers	microcontroller.ti.com
RFID	www.ti-rfid.com
RF/IF and ZigBee® Solutions	www.ti.com/lprf

Applications

Audio	www.ti.com/audio
Automotive	www.ti.com/automotive
Broadband	www.ti.com/broadband
Digital Control	www.ti.com/digitalcontrol
Medical	www.ti.com/medical
Military	www.ti.com/military
Optical Networking	www.ti.com/opticalnetwork
Security	www.ti.com/security
Telephony	www.ti.com/telephony
Video & Imaging	www.ti.com/video
Wireless	www.ti.com/wireless

Mailing Address: Texas Instruments, Post Office Box 655303, Dallas, Texas 75265
Copyright 2008, Texas Instruments Incorporated