

Specification of Smart-Abs TS5700N8500

1. Scope

This document defines the specification of the products described below.

- (1) Name: Smart-Abs
- (2) Model number: TS5700N8500
- (3) Functional classification: SA48-17/33bit-LPS-5V

This specification is translated by original Japanese version. When Japanese and English have a difference, we give priority to a Japanese version.

2. Basic Function

This Smart-Abs has basic functions as follows.

- (1) This Smart-Abs is a full absolute encoder that has the resolution of 17 bits per revolution and the multi-turn counting of 16 bits, as the total resolution of 33 bits, and transmits the output of full absolute position data as serial digital data in response to an external request. But when the battery is not connected, it functions as a full absolute encoder that transmits the output of full absolute position data with 17 bits per revolution as serial digital data in response to an external request.
- (2) It is capable of saving the multi-turn data and operating the multi-turn counter by mean of connecting to a battery even when the main power supply is suddenly cut off such as for a power outage.
- (3) It is capable of writing any desired 762 bytes data into the EEPROM at any time.
- (4) Serial communications are done by communication rate 2.5Mbps.
- (5) The temperature on the encoder can be measured by using a part of the EEPROM access function.

3. Environmental Conditions

Items		Specification	Remarks
Operating temperature range		-10~ +85 °C	---
Storage temperature range		-20~ +90 °C	---
Humidity		90 % RH max.	At 40 °C, 96 hours, without condensation
Vibration-resistance	Test condition	5~ 58 Hz, Double amplitude of 1.5 mm; 58~ 2,000 Hz, 98 m/s ²	2 hours for each axis, total 6 hours
Shock-resistance	Test condition	1,960 m/s ² , 11 ms	3 times for each direction, total 18 times



第 版

DWG NO.	3	4	5	6	7	8	9	10	11	12	SHEET
S P C 0 0 7 7 9 6 W 0 0											2 /

4. Mechanical Specification

Items	Specification	Remarks
Outline	OTD005653W00	---
Protecting structure	IP 40	IEC529 When shaft fitted

Items	Specification Ta=25 °C			Remarks	Unit	
	Min.	Typ.	Max.			
Mass	---	---	0.3	For only main body, except the cable	kg	
Moment of inertia	---	6.5	---	GD ² /4	x 10 ⁻⁶ kg·m ²	
Friction torque	---	---	9.8	At 20 °C	x 10 ⁻³ N·m	
Allowable Shaft Load	Radial	—	—	27	—	N
	Axial	—	—	8.7	—	N
	Tilt	—	—	0.1	—	°
Permissible rotational speed	---	---	6,000	---	min ⁻¹	
Permissible angular acceleration	---	---	80,000	---	rad/s ²	
Mechanical life	---	10,000	---	At 85°C, 6,000min ⁻¹ (reference)	h	



第 版

DWG NO.	3	4	5	6	7	8	9	10	11	12	SHEET
S P C 0 0 7 7 9 6 W 0 0											3 /

5. Electrical Specification

5.1 Definition of Terms

Items	Definition
Normal mode	The operating state of Smart-Abs by the main power supply.
Power-off mode	The operating state of Smart-Abs while the main power supply is off. The multi-turn data is saved and the multi-turn counter is operated. After it returns to the Normal mode, the data can be transmitted to outside.
Power-off timer	During minimum 5 seconds after the main power supply is turned off, maximum rotational speed and maximum angular acceleration that are specified in Paragraph 5.4.2 Electrical Specification for Multi-turn Signal are performed within the value shown in the Power-off timer operation.
Power-off operation	Maximum rotational speed and maximum angular acceleration that are specified in Paragraph 5.4.2 Electrical Specification for Multi-turn Signal are performed within the value shown in the Power-off operation.

5.2 Electrical Connections

Color of Lead Wires	Functions	Remarks
Red	VCC	Main power supply: DC +5 V \pm 5 %
Black	GND	---
Brown	VB	External battery power supply (Note 1)
Brown/Black	GND	---
Blue	SD	Serial data signal
Blue/Black	$\overline{\text{SD}}$	
Gray	CASE GND	---
Shield	N.C.	---

Cable Size

OD : $\phi 6.0 \pm 0.2\text{mm}$
 CORE : 19/ $\phi 0.08$ (AWG28)
 INSULATOR : $\phi 0.76\text{mm}$ TYP

Note 1: An external battery is needed when Smart-Abs operates in the power-off mode.
 Refer to Paragraph 6.4 Description of Status Flag Function for details of the error flag when the main power supply is turned on with no external battery.



第 版

DWG NO.	3	4	5	6	7	8	9	10	11	12	SHEET
S P C 0 0 7 7 9 6 W 0 0											4 /

5.3 Absolute Maximum Rating

Items	Specification	Unit
Main power supply voltage	5.50	V
External battery voltage	4.75	V

5.4 Common Electrical Specification

Items	Specification Ta=25 °C			Remarks	Unit	
	Min.	Typ.	Max.			
Main power supply voltage	4.75	5	5.25	---	V	
External battery voltage	---	3.6	---	---	V	
Switching voltage for operating mode	4.0	4.2	4.4	Normal→Power-off mode	V	
	4.1	4.3	4.5	Normal←Power-off mode	V	
Battery error generating voltage	2.5	2.75	3.0	External battery voltage	V	
Battery alarm generating voltage	3.0	3.1	3.2	External battery voltage	V	
Over heat detection temperature	-3	—	+3	The temperature setting is paragraph 7	°C	
Current consumption						
Main power supply						
Normal mode	---	125	150	No load	mA	
External battery						
Normal mode	---	3.6	---	---	μA	
Power -off mode	Power-off timer	---	150	---	μA	
		Power-off operation	---	65	110	μA
Differential output	SD/ DS	"H" level	3.5	---	At 5V of main power supply	V
		"L" level	---	---		
Rise time/Fall time	---	---	100	Example of circuit: Para. 11	ns	
Insulation resistance	20	---	---	Between case & GND by using DC-500V Megohm meter; Inapplicable to the products.	MΩ	
Dielectric strength	AC 100	---	---	For 1 minute, between case & GND; Inapplicable to the products.	V	
Power-on standby time (Note 2)	---	---	1	External battery existed	s	
	---	---	1.5	No external battery	s	
Electrical life	---	24,000	---	MTBF at 85 °C	h	

第 版

DWG NO.	3	4	5	6	7	8	9	10	11	12	SHEET
S P C 0 0 7 7 9 6 W 0 0											5 /

Note 2: Power-on standby time is defined as the time just after the voltage of main power supply increases to the Switching voltage of operating mode from the Power-off mode to the Normal mode.

Any external request cannot be accepted during the power-on standby time.

In case when the main power supply is turned on in the condition that the external battery is connected the output state of line driver of Smart-abs is "Hi-Z" during power-on standby time.

In case when the main power supply is turned on in the condition that the external battery is not connected, the output state of line driver becomes indefinite (i.e. "H", "L" or "Hi-Z") during the power-on standby time. (Refer to Paragraph 5.4 Common Electrical Specification.)



第 版

DWG NO.	3	4	5	6	7	8	9	10	11	12	SHEET	
S	P	C	0	0	7	7	9	6	W	0	0	6 /

5.4.1 Electrical Specification for One Revolution Single

Items		Specification Ta=25 °C	Remarks
Resolution		2^{17}	When main power supply is turned on at the rotational speed of 100 min^{-1} or more, the accuracy is 5 bits. (Note 3)
Maximum rotational speed	Normal mode	$6,000 \text{ min}^{-1}$	---
Maximum angular acceleration	Normal mode	$80,000 \text{ rad/s}^2$	---
Output code		Pure binary	---
Incremental direction		CCW	In view from the shaft end of Smart-Abs
Accumulated pitch error		$\pm 80 \text{ arc-sec}$	Target value
Adjoining pitch error $\triangle 4$		$\pm 20 \text{ arc-sec}$	
Repeatability at main power- on		$\pm 80 \text{ arc-sec}$	---

Note 3: When one revolution data of 2^{17} is not assured, Full absolute status comes out as a status flag. Refer to Paragraph 6.4 Description of Status Flag Function.

(I) In case where main power supply is turned on while the shaft of Smart-Abs rotates at 100 min^{-1} or more in one direction (FS: "1"), the operation of Smart-Abs is shown in the following figure.

Example: Rotation of CCW direction in view from the shaft end of Smart-Abs

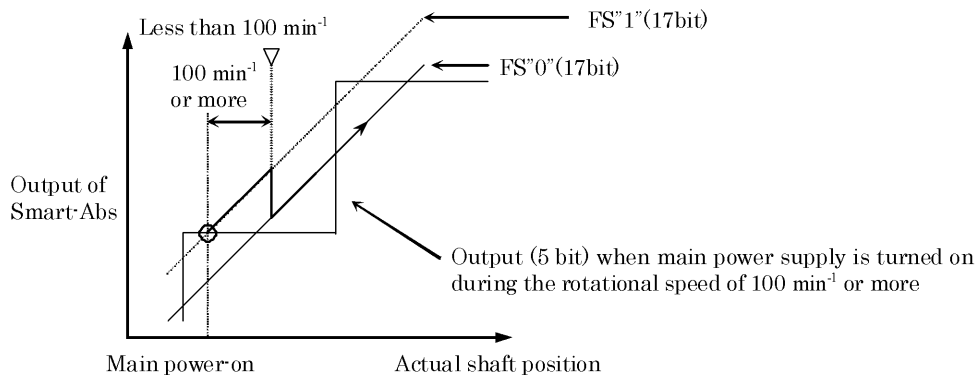

(II) In case where main power supply is turned on while the rotational speed is less than 100 min^{-1} in one direction (FS: "0"), the operation of Smart-Abs is increased or decreased monotonously, except the variation depending on the error components specified as the adjoining pitch error.



第 版

DWG NO.	3	4	5	6	7	8	9	10	11	12	SHEET
S P C 0 0 7 7 9 6 W 0 0											7 /

5.4.2 Electrical Specification for Multi-turn Signal

Items	Specification Ta=25 °C	Remarks
Resolution	1 C/T	---
Multi-turn counting range	2^{16}	0~ 65535 (Note 5,6)
Maximum rotational speed		
Normal mode	$6,000 \text{ min}^{-1}$	---
Power-off mode		
Power-off timer	$6,000 \text{ min}^{-1}$	Duration is 5 seconds
Power-off operation	$6,000 \text{ min}^{-1}$	---
Maximum angular acceleration		
Normal mode	$80,000 \text{ rad/s}^2$	---
Power-off mode		
Power-off timer	$80,000 \text{ rad/s}^2$	---
Power-off operation	$4,000 \text{ rad/s}^2$	---
Output code	Pure binary	---
Incremental direction	CCW	In view from the shaft end of Smart-Abs

Note 5: When the battery error (BE) occurs, Counter overflow is returned to operate normally by resetting its multi-turn data.

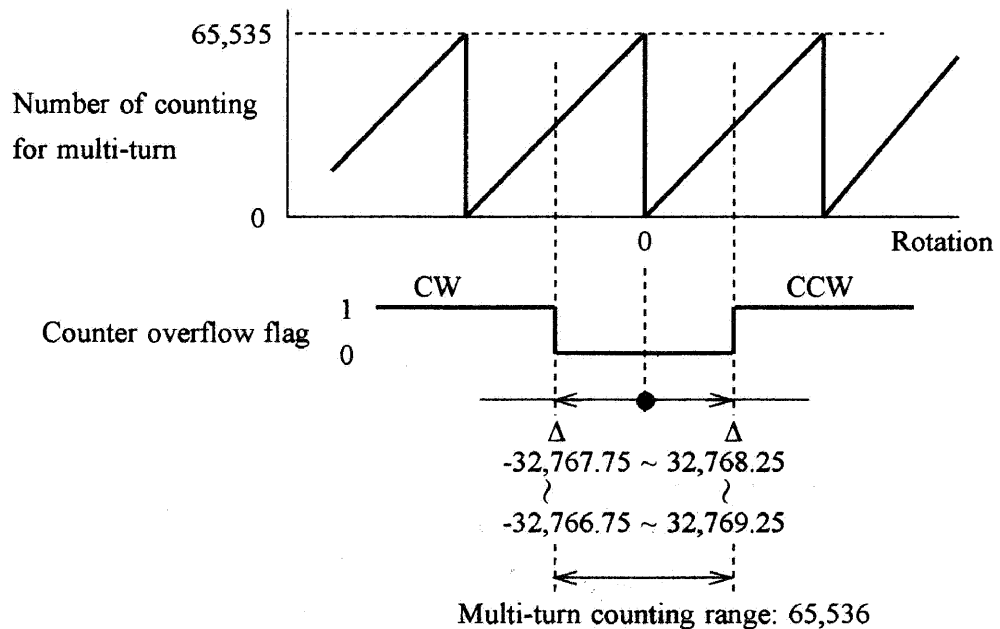

Valid Condition of Counter Overflow Flag



第 版

DWG NO.	3	4	5	6	7	8	9	10	11	12	SHEET
S P C 0 0 7 7 9 6 W 0 0											8 /

Note 6: Occurrence condition of Over-speed error

The logic "1" is transmitted when the rotational speed of shaft exceeds the responsible rotational speed.

In case where the rotational speed of input shaft exceeds the tracking speed of internal circuit of Smart-Abs during Power-off operation, the relation of rotational speed versus Over-speed error is as Table A.

Table A. Relation of Rotational Speed vs. Over-Speed Error

Rotational speed of Smart-Abs shaft	Over-speed error
0~ 6,000 min ⁻¹	"0"
6,000~ 14,000 min ⁻¹ (Calculated value)	"0": Normal detection of multi-turn data "1": Wrong detection of multi-turn data
More than 14,000 min ⁻¹ (Calculated value)	Indefinite

In case when the rotational speed is 0~ 14,000 min⁻¹ (Calculated value), the detection of multi-turn data are normal for the logic "0" of Over-speed error. However when the logic of Over-speed error is "1", the reset is needed because it may be abnormal. Therefore it is recommended to use within the rotational speed of 0~ 6,000 min⁻¹.

During the Power-off operation, in case when the angular acceleration exceeds 4,000 rad/s² even while the rotational speed is less than the specified tracking speed, the relation of rotational speed versus Over-speed error is as Table B.

Table B. Relation of Rotational speed vs. Over-speed Error

Angular acceleration of Smart-Abs shaft	Over-speed error
0~ 4,000 rad/s ²	"0"
4,000~ 28,000 rad/s ² (Calculated value)	"0": Normal detection of multi-turn data "1": Wrong detection of multi-turn data
More than 28,000 rad/s ² (Calculated value)	Indefinite

In case where the angular acceleration is 0~ 28,000 rad/s² (Calculated value), the detection of multi-turn data are normal for the logic "0" of Over-speed error. However when the logic of Over-speed error is "1", reset is needed because it may be abnormal. Therefore it is recommended to use within the angular acceleration of 0~ 4,000 rad/s².



第 版

DWG NO.	3	4	5	6	7	8	9	10	11	12	SHEET
S P C 0 0 7 7 9 6 W 0 0											9 /

6. Specification for Serial Communication (T-format)

6.1 General Specification

Items	Specification	Remarks
Communication code	NRZ	---
Transmission type	Differential line driver	Equivalent to RS 485
Reception type	Differential line receiver	Equivalent to RS 485
Transmission data	One revolution data	17 bits
	Multi-turn data	16 bits (0~ 65,535)
	Status flag	(1) Over-speed (2) Full absolute status (3) Counting error (4) Counter overflow (5) Over-heat (6) Multi-turn error (7) Battery alarm (8) Battery error
Synchronization type	Synchronizing step by step	---
Modulation type	Base band (No modulation)	---
Communication rate	2.5 Mbps	Permissible jitter: ±100 ns
Frame format	See details in & after Paragraph 6.2	---

6.1.1 EEPROM

Items	Specification	Remarks
Accessible address	0~ 126(decimal) × 6 pages	Data at shipping: All "0"
Page change	Page change is done by writing in address 127(decimal).	Effective page: 0~5 (It is a part of page 7 as the temperature measurement function.) The default when a main power supply is turned on is page 0.
Permissible times for writing	Total 100,000 times	Writing 1 access = 1 time Page change is not counted to writing times.



第 版

DWG NO.	3	4	5	6	7	8	9	10	11	12	SHEET
S P C 0 0 7 7 9 6 W 0 0											10 /

6.2 Frame Format

6.2.1 Data Readout from Smart-Abs

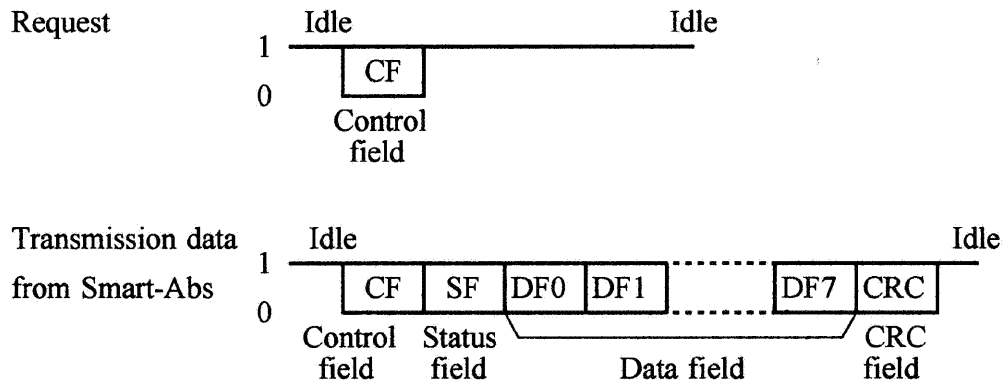

Figure 1. Frame Format for Reading-out Smart-Abs Data



第 版

DWG NO.	3	4	5	6	7	8	9	10	11	12	SHEET
S P C 0 0 7 7 9 6 W 0 0											11 /

6.2.2 Access (Writing) to EEPROM

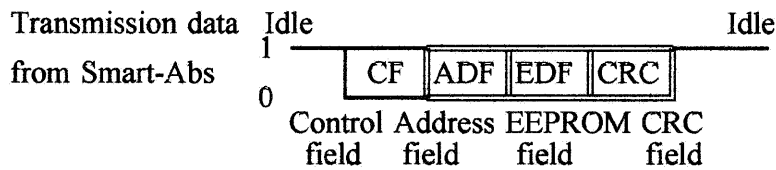
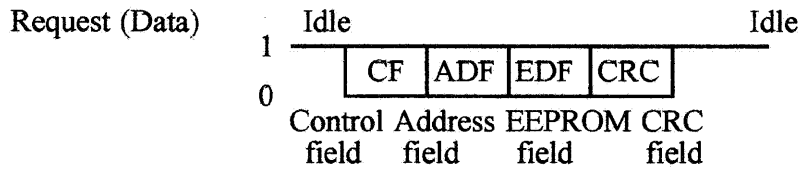



 means the field that changes its information depending on the request

CF is transmitted as the same content of its request.

Figure 2. Frame Format for Writing to Smart-Abs

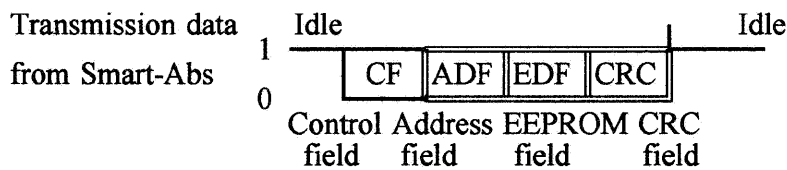
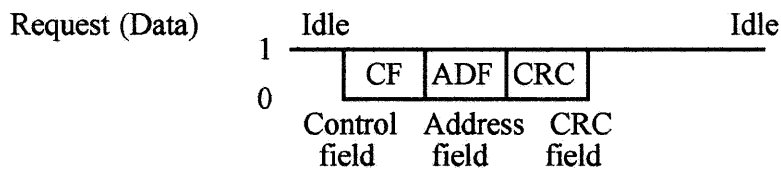
6.2.3 Access (Readout) from EEPROM



 means the field that changes its information depending on the request.

CF is transmitted as the same content of its request.

Figure 3. Frame Format for Readout from Smart-Abs



第 版

DWG NO.	3	4	5	6	7	8	9	10	11	12	SHEET
S P C 0 0 7 7 9 6 W 0 0											12 /

6.3 Details of Each Field

6.3.1 Control Field (CF)

The structure of Control field is shown in Figure 4.

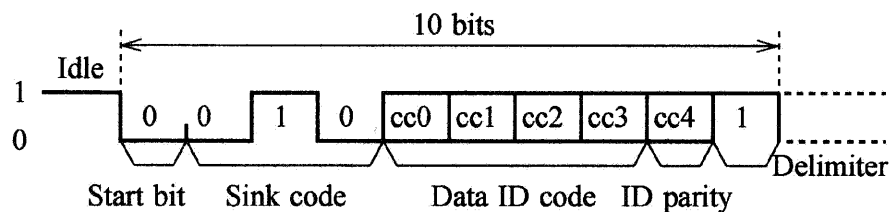

Figure 4. Structure of Control Field

- (1) Start bit: Fixed.
- (2) Sink code: Fixed.
- (3) Data ID code: By means of designating one of Data ID code shown in Table 1, the data shown in Table 2 is transmitted from Smart-Abs.
Designate the Data ID code according to the application shown in Table 1. For example, never use Data ID code for Reset instead of Data ID code for Readout.
- (4) ID parity: This is the Parity for Data ID code.
- (5) Delimiter: Fixed.

Table 1. List of Data ID Code

Application	Data ID	Code				Parity
		cc0	cc1	cc2	cc3	cc4
Data readout	Data ID 0	0	0	0	0	0
	Data ID 1	1	0	0	0	1
	Data ID 2	0	1	0	0	1
	Data ID 3	1	1	0	0	0
Writing to EEPROM	Data ID 6	0	1	1	0	0
Readout from EEPROM	Data ID D	1	0	1	1	1
Reset	Data ID 7	1	1	1	0	1
	Data ID 8	0	0	0	1	1
	Data ID C	0	0	1	1	0



第 版

DWG NO.	3	4	5	6	7	8	9	10	11	12	SHEET
S P C 0 0 7 7 9 6 W 0 0											13 /

6.3.2 Status Field (SF)

The structure of Status field is shown in Figure 5.

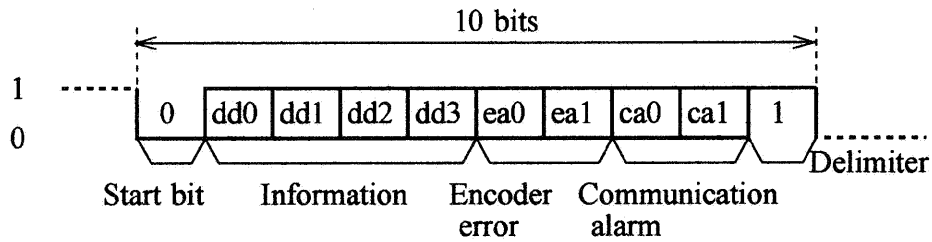

Figure 5. Structure of Status Field

- (1) Start bit: Fixed.
- (2) Information: All are fixed to "0".
- (3) Encoder error: Logic "1" is transmitted when any error occurs in Smart-Abs.

Bit	ea0	ea1
Logic when the error occurs	1	1
Description of error	Counting error	Logic-OR of Over-heat, Multi-turn error, Battery error and Battery alarm is transmitted.

When an error occurs in the bit of ea1, request "Data ID 3" to confirm the contents of ALMC in the data frame. Because Full absolute status, Over-speed and Counter overflow are not included in ea1, confirm them in ALMC.

- (4) Communication alarm: Logic "1" is transmitted when any error occurs in Smart-Abs.

Bit	ca0	ca1
Logic when the error occurs	1	1
Description of error	Logic "1" is transmitted when Parity error in Request frame occurs. Parity bit in Request Frame is located in cc4 of Data ID code.	Logic "1" is transmitted when Delimiter error in Request frame occurs.

When the Communication alarm occurs, the received data should be invalid without fail, and transmit the same Request signal again. When the Communication alarm occurs, the data of Data ID 3 is transmitted from Smart-Abs in spite of any kind of Transmission request.

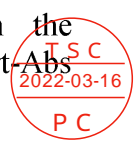

- (5) Delimiter: Fixed.

第 版

DWG NO.	3	4	5	6	7	8	9	10	11	12	SHEET
S P C 0 0 7 7 9 6 W 0 0											14 /

6.3.3 Data Field (DF0~ DF7)

The relation between Data ID code and Data field is shown in Table 2.

Table 2. List of Data Field

Data ID code	DF0	DF1	DF2	DF3	DF4	DF5	DF6	DF7
Data ID 0	ABS0	ABS1	ABS2					
Data ID 1	ABM0	ABM1	ABM2					
Data ID 2	ENID							
Data ID 3	ABS0	ABS1	ABS2	ENID	ABM0	ABM1	ABM2	ALMC
Data ID 7	ABS0	ABS1	ABS2					
Data ID 8	ABS0	ABS1	ABS2					
Data ID C	ABS0	ABS1	ABS2					

Note: Blank in above table means no data to be transmitted.

ABS0~ ABS2: Absolute data in one revolution.

ABS0 is located to lower bite and ABS2 is located to higher bite in the frame of total 24 bits. Higher 7 bits of ABS2 are always logic "0", and then the valid data consists of total 17 bits.

ABM0~ ABM2: Multi-turn data:

ABM0 is located to lower bite and ABM2 is located to higher bite in the frame of total 24 bits. ABS2 is always logic "0", and then the valid data consists of total 16 bits.



ENID: Encoder ID (= 11H, fixed)

ALMC: Encoder error (See Table 3.)

Table 3. ALMC

Bit	d70	d71	d72	d73	d74	d75	d76	d77
Logic when each error occurs	1	1	1	1	1	1	1	1
Name & its symbol	Over-speed	Full absolute status	Counting error	Counter overflow	Over-heat	Multi-turn error	Battery error	Battery alarm
	OS	FS	CE	OF	OH	ME	BE	BA



第 版

DWG NO.	3	4	5	6	7	8	9	10	11	12	SHEET
S P C 0 0 7 7 9 6 W 0 0											15 /

The structure of each Data field is shown in Figure 6.

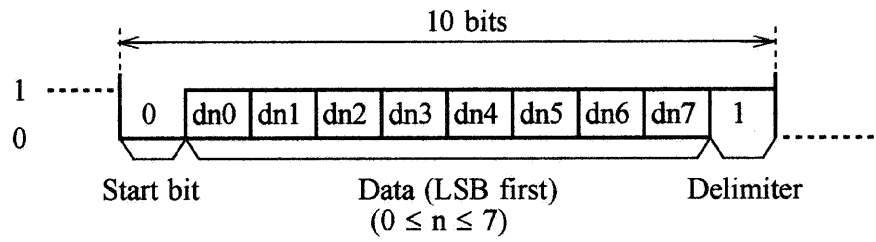

Figure 6. Structure of Data Field

- (1) Start bit: Fixed.
- (2) Data: Arranged with LSB first.
- (3) Delimiter: Fixed.



第 版

DWG NO.	3	4	5	6	7	8	9	10	11	12	SHEET
S P C 0 0 7 7 9 6 W 0 0											16 /

6.3.4 CRC Field (CRC)

The structure of CRC field is shown in Figure 7.

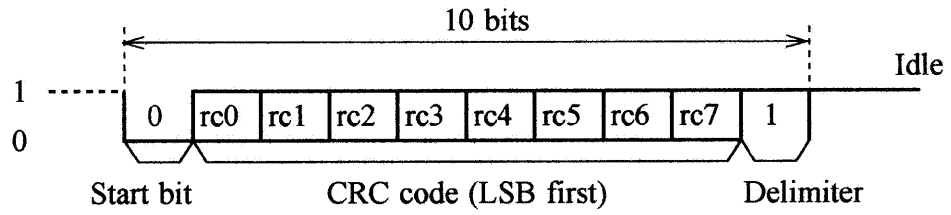

Figure 7. Structure of CRC Field

- (1) Start bit: Fixed.
- (2) CRC code: This code conforms to the equation of $G(X) = X^8 + 1$ ($X = rc0 \sim rc7$).
The data is arranged in LSB first.
The code is calculated from all bits without Start bit and Delimiter, of all fields except CRC field.
- (3) Delimiter: Fixed.



第 版

DWG NO.	3	4	5	6	7	8	9	10	11	12	SHEET
S P C 0 0 7 7 9 6 W 0 0											17 /

6.3.5 Address Field (ADF) and EEPROM Field (EDF)

The structure of ADF field is shown in Figure 8.

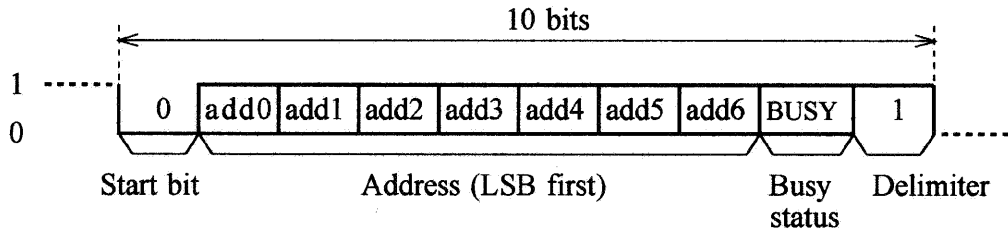

Figure 8. Structure of ADF Field

- (1) Start bit: Fixed.
- (2) Address: Address of EEPROM (0~ 127(decimal)) with LSB first.
The page is specified in address127, and it accesses 0~126.
Refer to Table.4.

Table.4 Address Map

Page Address	0	1	-----	5
1 2 7	0	1	-----	5
0				
1				
⋮				
1 2 4				
1 2 5				
1 2 6				

Data writing area

After the page is changed, it is not possible to access EEPROM between 18ms. The Busy status becomes "1" when accessing it. The default when a main power supply is turned on is page 0.



第 版

DWG NO.	3	4	5	6	7	8	9	10	11	12	SHEET
S P C 0 0 7 7 9 6 W 0 0											18 /

(3) Busy status: Access state to EEPROM can be checked by Busy status. The relation between Busy status and the data transmitted from Smart-Abs is shown in Table 5.

Table 5. Busy Status and Transmission Data

	Request	Transmission data from Smart-Abs			Description
	Busy	Busy	ADF	EDF	
Read-out	0	0	ADF of the Request	Proper data of EEPROM	Readout is normally completed.
		1	ADF of the Request	00 [HEX]	Writing is in practice, and any request for Readout is invalid.
Writing	0	0	ADF of the Request	EDF of the Request	Request for Writing was accepted.
		1	ADF of the Request	00 [HEX]	Writing is in practice and any request for Writing is invalid.

When the logic of Busy status in the data transmitted from Smart-Abs is "1", Writing is in practice. Writing by Request cannot be performed.

In order to confirm that Writing to EEPROM is normally completed, transmit the Readout request (Data ID D), because it is not possible to confirm by the response of Readout request (Data ID 6).

(4) Delimiter: Fixed.

(5) EDF: 8-bit data with LSB first

The structure of Data field is equivalent to Figure 6.



第 版

DWG NO.	3	4	5	6	7	8	9	10	11	12	SHEET
S P C 0 0 7 7 9 6 W 0 0											19 /

③ 6.4 Description of Status Flag



Name	Function		Battery		Action
			Exist	No	
Over-speed OS (Latched)	During the external battery driven after main power supply is turned off, logic "1" is generated when the shaft of Smart-Abs is rotated over the specified speed of the Power-off mode in Paragraph 5.4.2 Electrical Specification for Multi-turn Signal. After main power supply is turned on, it can be transmitted to outside. But this flag should be used as only its aim, because it may not be detected in some cases. (Note 6)		←	Indefinit	Reset error. (Refer to Paragraph 10.)
Full absolute status FS (Non-latched)	Logic "1" is transmitted when main power supply is turned on while the shaft of Smart-Abs is rotated at 100 min ⁻¹ or more. The accuracy of one revolution data is 5 bits while logic "1" is transmitted. When one revolution data is switched to the resolution of 17 bits, the flag is automatically released.		←	←	Make the rotational speed slow down to less than 100 min ⁻¹ , and wait until the flag is automatically released.
Counting error CE	Logic "1" is transmitted in either case I or II, when one revolution data is deviated by any malfunction or defect at main power-on.				Stop the servo system immediately.
	I (Non-latched)	When the shaft of Smart-Abs is rotated at 100 min ⁻¹ or more, error is detected every 45 ° in mechanical angle. The flag is automatically released at every 45 ° when the deviation of one revolution data is reduced to less than ±22.5 ° (typ.).	←	←	Error status is automatically released. Turn off and on the power supply.
	II (Latched during main power-on)	When the shaft of Smart-Abs is rotated at less than 100 min ⁻¹ , error is always detected. Logic "1" is transmitted when the deviation of one revolution data is ±0.7 ° (typ.) or more. Any deviation of one revolution data is automatically returned to the normal value at detection of error.	←	←	Reset error. (Refer to Paragraph 10.) Turn off and on the power supply.
Counter overflow OF (Latched)	Logic "1" is transmitted when the multi-turn counter is overflowed. In case when it is detected during main power-off, it can be transmitted to outside after main power-on. The flag detected once is held until reset in spite of main power-on/off and the counted value, but the multi-turn counter continues to operate as a cyclic counter of 0~65,535. When Battery error (BE) occurs, Counter overflow is normally operated by resetting the multi-turn data.		←	Indefinit	Reset error. (Refer to Paragraph 10.)
Over-heat OH (Latched)	Logic "1" is transmitted, when the temperature of the encoder substrate exceeds overheating detection temperature (Refer to Paragraph 5.4 Common Electrical Specification) during main power-on. (It doesn't operate at main power-off.)		←	←	Reset error after temperature of encoder is lowered. (Refer to Paragraph 10.)
Multi-turn error ME (Latched during main power-on)	Logic "1" is transmitted, when any bit-jump occurs in the multi-turn signal during main power-on. It is not operated during main power-off. The bit-jump is checked at every 12.8 μs.		←	←	Return to the origin. Reset error. (Refer to Paragraph 10.)
Battery alarm BA (Non-latched)	Logic "1" is transmitted, when the external battery voltage is 3.1 ±0.1 V or less during main power-on. (Refer to Paragraph 5.4 Common Electrical Specification.) Error is automatically released when the external battery voltage is returned to normal value.		←	←	Error status is automatically released. It is necessary to check or replace the external battery.
Battery error BE (Latched)	Logic "1" is generated when the external battery voltage is 2.75 ±0.25V or less during main power-off. (Refer to Paragraph 5.4 Common Electrical Specification.), and it can be transmitted to outside after main power-on. When this flag occurs immediately after main power-on, the multi-turn data may be abnormal at the same time.		←	←	Reset error and multi-turn data. (Refer to Paragraph 10.) It is necessary to check or replace the external battery. 2022-03-16 P.C.

Note: Even if the battery exists, it operates as same as no battery when the battery voltage is 2.5~3.0V or less and Battery error (BE) occurs.

第 版

DWG NO.	3	4	5	6	7	8	9	10	11	12	SHEET
S P C 0 0 7 7 9 6 W 0 0											20 /

7. Method of Over-heat setting and measuring temperature

7.1 Outline

The setting of Over-heat and measuring temperature on the encoder substrate can be done by using the access to EEPROM.

7.2 Method of Over-heat setting

Over-heat is set by using the page 7 address 4 of EEPROM.
Setting change is counted to writing times.



7.2.1 (example) When you detect Over-heat at 90°C

"DA (hexadecimal)" is written in the page 7 address 4 of EEPROM.

$$DA \text{ (hexadecimal)} = 90 + 128 \text{ (decimal)} = \text{Detected temperature} + 128 \text{ (decimal)}$$



7.2.2 (example) When you do not cause Over-heat

"00 (hexadecimal)" is written in the page 7 address 4 of EEPROM.
Even 1 is acceptable excluding MSB.

$$00 \text{ (hexadecimal)} = 0 \text{ (decimal)}$$

7.2.3 Confirm method of setting

The page 7 address 4 data of EEPROM is read.



7.2.4 Over-heat detection temperature setting table

Setting at shipping DA (hexadecimal) : Over-heat is detected at 90°C.

Address	EEPROM data							Over-heat detection temperature (Accuracy ±3 °C)
	edd7	edd6 · · · · · edd0						
Page 7 Address 4	0	X	X	X	X	X	X	Not output
	1	0	0	0	0	0	0	+1 °C
	1	0	0	0	0	0	1	+2 °C
	1	0	0	0	0	0	1	+3 °C
	· ·	· · ·						· · ·
	1	1	1	1	1	1	0	+126 °C
	1	1	1	1	1	1	1	+127 °C

“X” : “0” or “1”



第 版

DWG NO.	3	4	5	6	7	8	9	10	11	12	SHEET
S P C	0	0	7	7	9	6	W	0	0	21	/

7.3 Method of measuring temperature on encoder substrate

The temperature on the encoder substrate is measured by using the page 7 address 5 of EEPROM.

7.3.1 (example) When the reading data is 3C(hexadecimal)

The page 7 address 5 data of EEPROM is read.

The reading data is converted into the decimal, and the temperature on the encoder substrate becomes 60°C.

$$3C \text{ (hexadecimal)} = 60 \text{ (decimal)}$$

7.3.2 Reading data / temperature measurements comparison table

Address	EEPROM data								Temperature measurements (Accuracy ±3 °C)
	edd7	edd6				edd0		
Page 7	1	0	0	0	0	0	0	0	-128 °C
Address 5	1	0	0	0	0	0	0	1	-127 °C

	1	1	1	1	1	1	1	1	-1 °C
	0	0	0	0	0	0	0	0	±0 °C
	0	0	0	0	0	0	0	1	+1 °C

	0	1	1	1	1	1	1	0	+126 °C
	0	1	1	1	1	1	1	1	+127 °C

7.4 Notes

- ① When a main power supply is turned on, it takes 5 seconds or less until an accurate temperature can be measured.
- ② Please use Over-heat detection temperature setting at 1°C or more.



第 版

DWG NO.	3	4	5	6	7	8	9	10	11	12	SHEET
S P C 0 0 7 7 9 6 W 0 0											22 /

8. Detection of Data Readout Frame

8.1 Detection of Start Frame

In the Control field (CF) the first logic "0" after the idle is detected as start of frame, and if the following 3 bits are conformed to Sink code, it is judged as a true Start frame. If they are not conformed to Sink code, it continues to search and detect another first logic "0".

The Data frame is transmitted by starting at $3 \mu s$ (typ.) after receiving the Delimiter signal of Request frame.

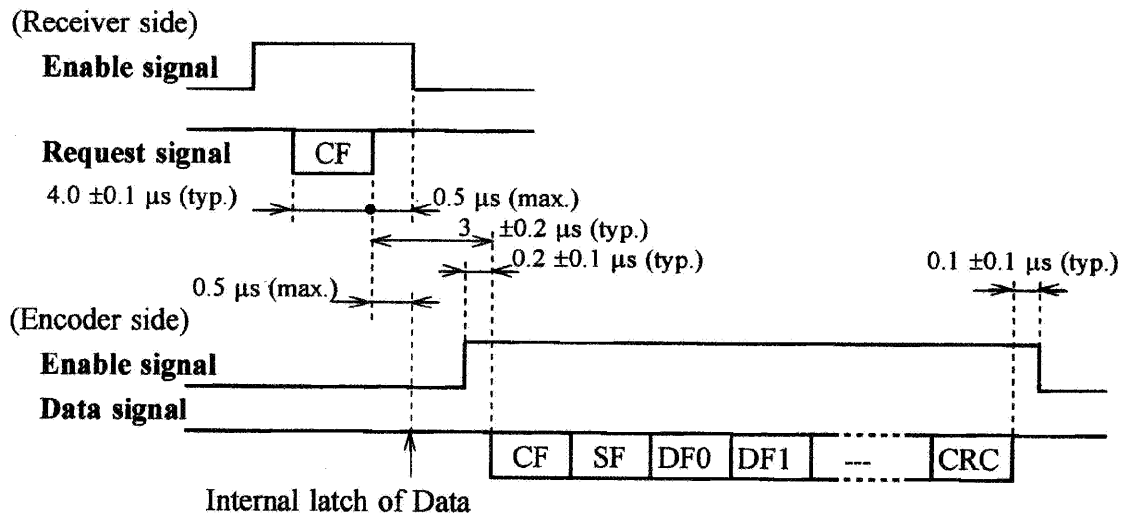

Figure 9. Detection of Frame

8.2 End of Frame

After the Start frame is detected, if there is no Start bit after the Delimiter, End of Frame is judged. Therefore there is no field that means the end of frame.

8.3 Idle

Idle means a space between each frame and its next frame. The logic of output in transmission side is fixed to "1".

8.4 Transmission Data at Abnormal Request

When any received Request is abnormal, the transmission data from Smart-Abs is shown in Table 5.

Table 5. Transmission Data at Abnormal Request

No.	Condition	Transmission Data
1	Logic of Sink code is abnormal.	Data is not transmitted.
2	Data ID code is not 0, 1, 2, 3, 7, 8 or C.	The data as same as Data ID 3 is transmitted. (Refer to Table 2.)
3	Logic of Parity is abnormal.	
4	Logic of Delimiter is abnormal.	

第 版

DWG NO.	3	4	5	6	7	8	9	10	11	12	SHEET
S P C 0 0 7 7 9 6 W 0 0											23 /

9. Detection of Access Frame to EEPROM

9.1 Detection of Start Frame

The first logic "0" after the idle is detected as start of frame, and if the following 3 bits are conformed to Sink code, it is judged as a true Start frame. If they are not conformed to Sink code, it continues to search and detect another first logic "0".

(Receiver side)

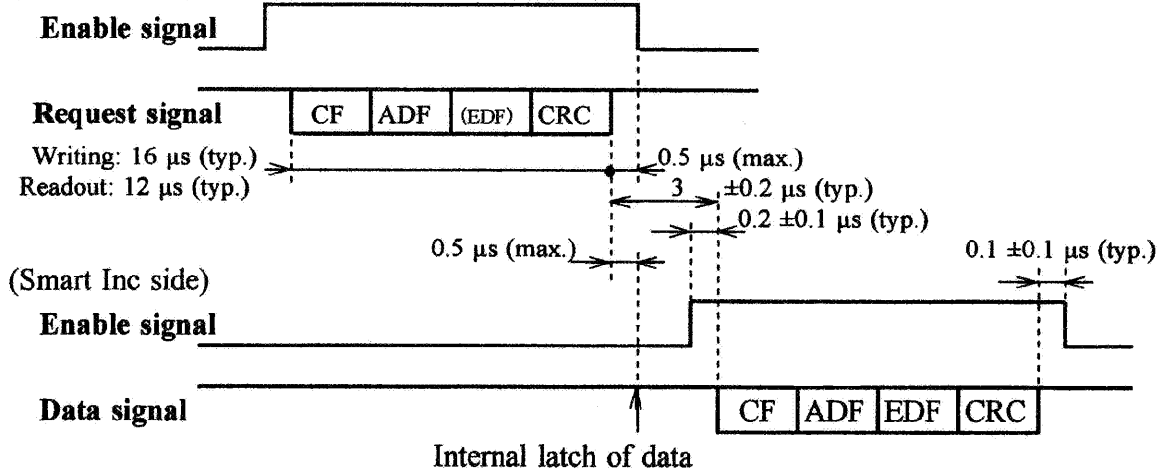

Figure 10. Detection of Frame

Note: Smart-Abs starts to transmit the response data at 3 μs (typ.) after it receives a Access request to EEPROM (Data ID 6 or D). Note that the response data for Writing request (Data ID 6) means only to have received a Data ID 6 but not to complete its writing process. (The completion of writing data to EEPROM is at 18 ms max. after receiving its Request.)

9.2 End of Frame

After the Start frame is detected, if there is no Start bit after the Delimiter, End of Frame is judged. Therefore there is no field that means the end of frame.

9.3 Idle

Idle means a space between each frame and its next frame. The logic of output in transmission side is fixed to "1".

9.4 Transmission Data at Abnormal Request

When any received Request is abnormal, the transmission data from Smart-Abs is shown in Table 6.

Table 6. Transmission Data at Abnormal Request

No.	Condition	Transmission Data
1	Logic of Sink code is abnormal.	Data is not transmitted.
2	Address area not to be open for user is designated.	The data as same as Data ID 3 is transmitted. (Refer to Table 2.)
3	Data ID code is not 6 or D.	
4	Logic of Parity is abnormal.	
5	Logic of Delimiter is abnormal.	
6	Logic of CRC is abnormal.	

第 版

DWG NO.	3	4	5	6	7	8	9	10	11	12	SHEET
S P C 0 0 7 7 9 6 W 0 0											24 /

10. Note for Transmitting Request

Function	Data ID	Description
Readout of data	0, 1, 2 & 3	Transmit Data ID code (Table 1) according to the List of Data Field (Table 2) to Smart-Abs. Because the receiver IC conformable to RS-485 is used in Smart-Abs, transmit by the driver IC conformable to RS-485 (for example, ADM485) or equivalent.
Reset of one revolution data	8	Transmit 10 times in one sequence to Smart-Abs with the interval of 40μs or more at stationary of the shaft. * One revolution data can be reset to 0 ±0.35 ° (max.) in mechanical angle position at any desired position. The angle position that is reset once is kept even after the power supply is turned off in spite of existing the external battery.
Reset of multi-turn data and all error	C	Transmit 10 times in one sequence to Smart-Abs with the interval of 40μs or more at stationary of the shaft. * Multi-turn data is reset. (One revolution data is not reset.) All latched errors (i.e. Over-speed, Counter overflow, Over-heat, Multi-turn error, Counting error II and Battery error) are reset at the same time.
Reset of all error	7	Transmit 10 times in one sequence to Smart-Abs with the interval of 40μs or more at stationary of the shaft. * All latched errors (i.e. Over-speed, Counter overflow, Over-heat, Multi-turn error, Counting error II and Battery error) are reset.
Access to EEPROM	6	"User Data" of 8 bits can be written to the address designated. It is recommended to confirm that the writing was properly performed by means of designating "Data ID D". (For confirming the data, turn off and on the main power supply or page is specified again.)
	D	"User Data" of 8 bits can be read out from the address designated. Regarding the transmission method for Readout request, refer to Paragraphs 6.2.3 and 6.3.5.

Note *: Smart-Abs transmits the response data described in Table 2 at the time when each Request is received. However any error information in the response data is not reset until Reset is executed.

For resetting one revolution data, it takes maximum 18 ms until the Reset is executed after Request data ID 8 is received 10 times, because the writing process to EEPROM should be carried out.

第 版

DWG NO.	3	4	5	6	7	8	9	10	11	12	SHEET
S P C 0 0 7 7 9 6 W 0 0											25 /

11. Circuit Diagram of Transmitter and Receiver

An example of circuit diagram of the transmitter and receiver is shown in Figure 11.

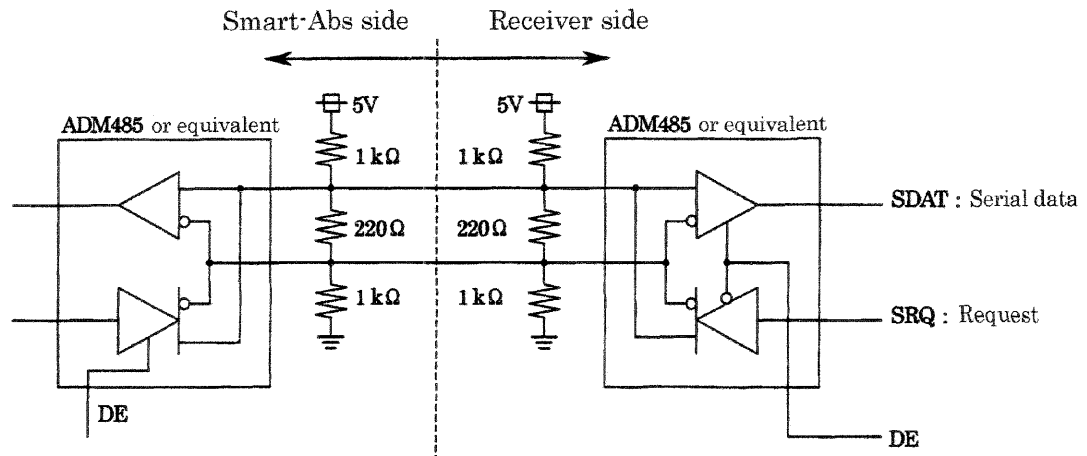

Figure 11. Example of Transmitter and Receiver Circuit

Never transmit any Request to Smart-Abs while it transmits the data. The interface circuit of Smart-Abs may be broken down if any Request is transmitted to Smart-Abs by mistake during this period.

Smart-Abs is always in the receiving mode except it is transmitting data.



第 版

DWG NO.	3	4	5	6	7	8	9	10	11	12	SHEET
S P C 0 0 7 7 9 6 W 0 0											26 /

12. Guarantee of Products

Guaranteed term of these products without cost is within one year after delivery, except the case of defect or deterioration of quality caused by disassembling, changing, re-assembling, mis-using, or other intention or fault by users.

However we, Tamagawa Seiki Co., Ltd., could continue to maintain the products properly even after above guaranteed term to keep performances of the products at your expense by request.

The predicted Mean Time Before Failure (MTBF) of these products is considered to be enough long, but the predictable failure rate is not zero. The user is advised, therefore, that the user should assume all troubles resulted by these products when they might be failed, and multiple safety means for them should be incorporated into your products, systems and/or equipment to prevent extending to a serious system failure.



第 版

DWG NO.	3	4	5	6	7	8	9	10	11	12	SHEET
S P C 0 0 7 7 9 6 W 0 0											27 /