

Isolated CAN Transceiver EVM

This User Guide details the design and operation of the evaluation module (EVM) for the ISO1050 isolated CAN transceiver.

This Guide explains the user configurable I/O loads for the EVM configurations, and presents a typical lab setup and typical output waveforms.

CAUTION

Please note that while these devices provide galvanic isolation of up to 4000 V, this EVM cannot be used for isolation voltage testing. It is designed for the evaluation of device operating parameters only and may be damaged if high voltage (> 5.25 V) is applied anywhere in the circuit.

Contents

1	Introduction	2
	1.1 Overview	2
	1.2 The Functional Configuration of the Isolated CAN Transceiver	2
	1.3 The Isolated CAN EVM	3
2	EVM Setup and Operation.....	6
	2.1 Overview	6

List of Figures

1	The ISO1050 Function Diagram and Pinout	2
2	ISO CAN Transceiver EVM Layout.....	3
3	The Isolated CAN EVM Schematic.....	4
4	Basic Isolated CAN Transceiver EVM Operation.....	6
5	Typical Waveforms Without Common-mode Loading	7
6	Common-mode Measurement Waveforms	8

List of Tables

1	Isolated CAN EVM Connections	5
---	------------------------------------	---

1 Introduction

1.1 Overview

The ISO1050 isolated CAN transceiver has an integrated silicon oxide (SiO₂) insulation barrier, which provides galvanic isolation between the controller side of a high-speed CAN transceiver and the bus side. Used in conjunction with isolated power supplies, these devices block high voltage, isolate grounds, and prevent noise currents on a data bus or other circuits from entering the local ground and interfering with or damaging sensitive circuitry.

These devices are ideal for long transmission lines since the ground loop is broken to allow for a much larger common-mode voltage range. The symmetrical isolation barrier of the device is tested to provide 2500 V_{rms} of isolation for 60 seconds between the bus-line transceiver and the logic-level interface.

Any cabled I/O can be subjected to electrical noise transients from various sources. These noise transients can cause damage to the transceiver and/or near-by sensitive circuitry if they are of sufficient magnitude and duration. The ISO1050 can significantly increase protection and reduce the risk of damage to expensive control circuits.

1.2 The Functional Configuration of the Isolated CAN Transceiver

The pin-out of the ISO1050 isolated CAN transceiver is displayed below. The EVM comes with the ISO1050 transceiver installed. For complete information on the ISO1050, refer to the latest datasheet from the Texas Instruments web site.

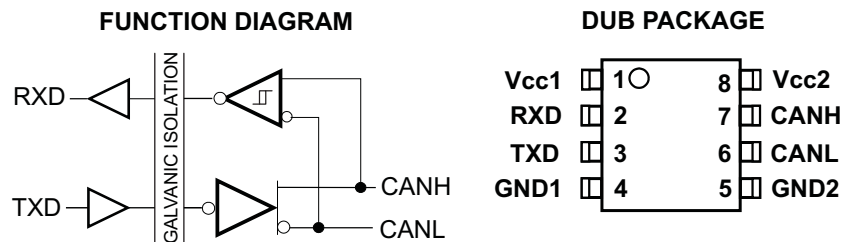

Figure 1. The ISO1050 Function Diagram and Pinout

1.3 The Isolated CAN EVM

This multi-functional EVM is designed for the evaluation of the ISO1050 isolated CAN transceiver. Input and output connections, as well as test points for measurements, are provided to help designers use this device, the world's first CAN transceiver with integrated isolation.

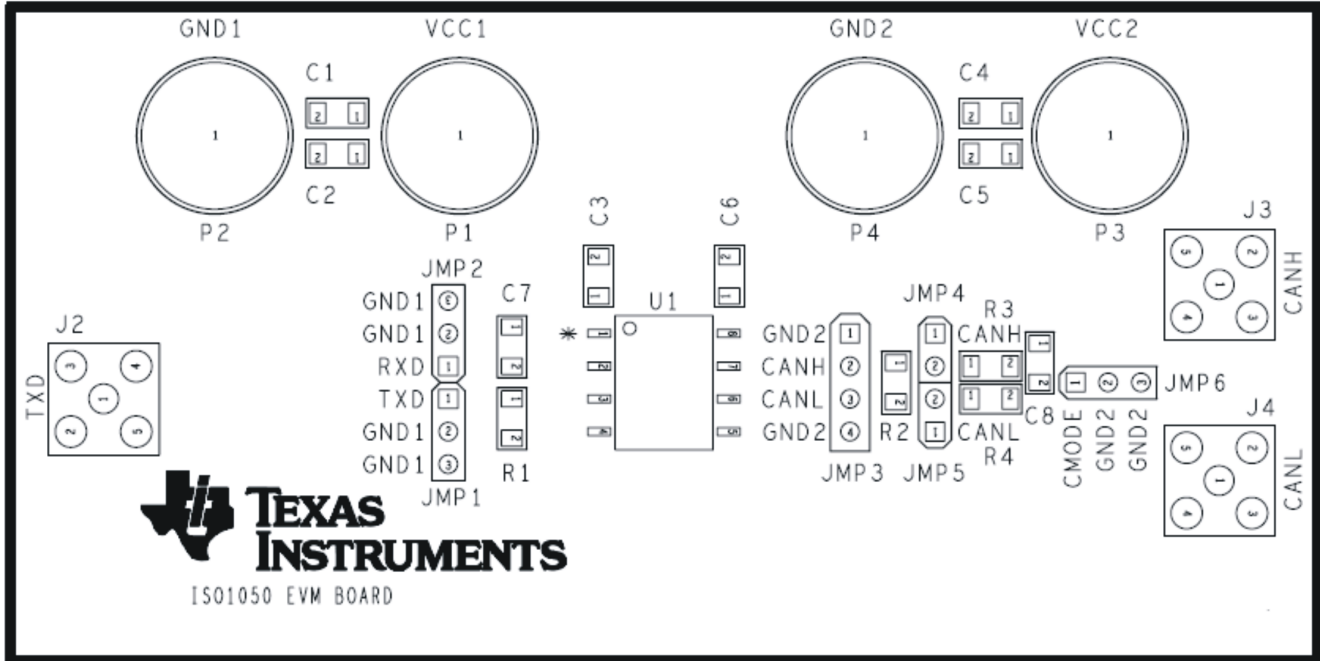

Figure 2. ISO CAN Transceiver EVM Layout

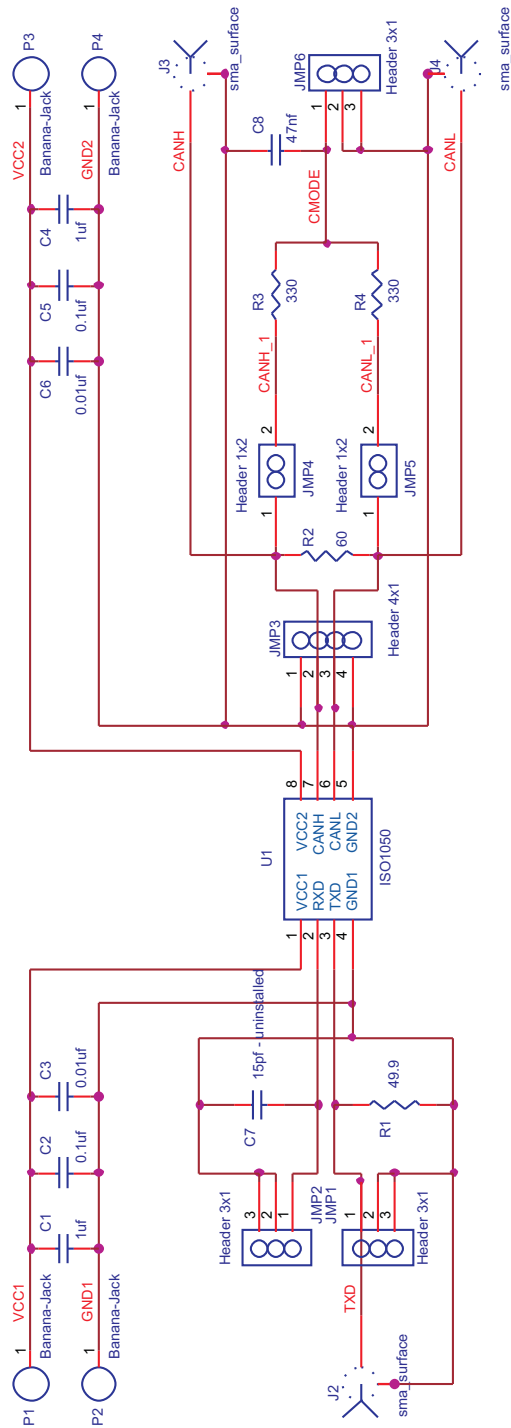

Figure 3. The Isolated CAN EVM Schematic

Table 1. Isolated CAN EVM Connections

Connection	Label	Description
P1	VCC1	Power supply for controller side of interface
P2	GND1	Ground for controller side of interface
P3	VCC2	Power supply for the bus side of interface
P4	GND2	Ground for the bus side of interface
J2	TXD	Transmit Data input to CAN transceiver
J3	CANH	CAN (High) bus input/output
J4	CANL	CAN (Low) bus input/output
JMP1	TXD, GND1, GND1	3-pin jumper - Test point jumper for Transmit Data input signal
JMP2	RXD, GND1, GND1	3-pin jumper - Test point jumper for Receive Data output signal
JMP3	GND2, CANH, CANL, GND2	4-pin jumper - Test points for CANH and CANL signals
JMP4	CANH	2-pin jumper - Jumper from CANH to common-mode load
JMP5	CANL	2-pin jumper - Jumper from CANL to common-mode load
JMP6	CMODE, GND2, GND2	3-pin jumper - Jumper for connection to common-mode voltage

2 EVM Setup and Operation

This chapter includes the setup and operation of the EVM for parameter performance evaluation. Typical waveforms are included.

2.1 Overview

The basic setup of the ISO1050 EVM in [Figure 4](#) has the two power supplies required to evaluate isolator performance with 3.3-V on one side and 5-V on the other. **If both side are to be evaluated at the same supply voltage, only one power supply is required, and can be used to power both sides of the EVM.**

Note that the EVM will typically have supply current from V_{CC1} (I_{CC1}) of less than 2 mA when idle and less than 3 mA when actively switching states. The supply current from V_{CC2} (I_{CC2}) will typically be less than 10 mA when idle in the recessive state, and will be typically be less than 80 mA in the dominant state with the default 60 Ohm load installed.

CAUTION

Note that this EVM is for operating parameter performance evaluation only and is not designed for isolation voltage testing. Any voltage applied beyond the maximum ratings of the CAN device may damage the EVM.

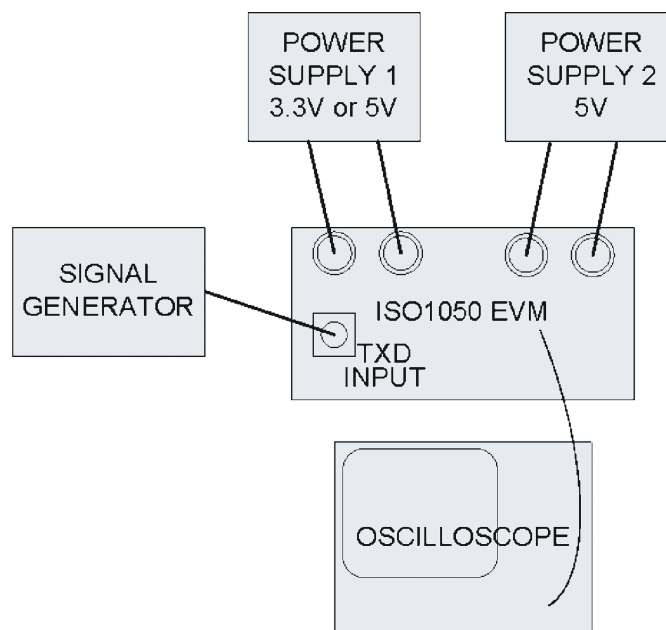

Figure 4. Basic Isolated CAN Transceiver EVM Operation

Operation without Common-mode Loading

With JMP4 and JMP5 open (no jumpers installed) the bus loading is a simple 60 Ohm resistor (R2) between CANH and CANL. This load represents a properly terminated CAN network with a 120 Ohm termination resistor at each end of the bus. This configuration may be used to examine the input and output characteristics of the isolated CAN transceiver.

In the plot below, Channel 1 is the TXD input data from a signal generator, representing 1 Mbps data to be transmitted. Channel 2 is the CANH signal, Channel 3 is the CANL signal. Channel 4 shows the received data on the RXD output. In this case, both supplies Vcc1 and Vcc2 were set to 5V.

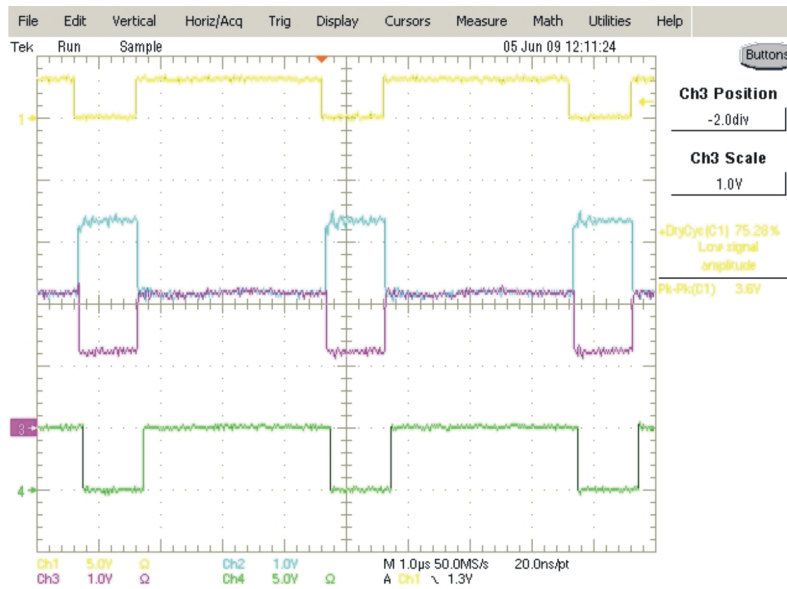

Figure 5. Typical Waveforms Without Common-mode Loading

Operation with Common-mode Loading

If jumpers are installed on JMP4 and JMP5, a connection is made from each bus line (CANH and CANL) through 330 Ohm resistors to a common-mode point (JMP6-1). This common-mode point can be used to measure the common-mode output voltage from the transceiver, or it can be used to apply a common-mode offset from an external source.

When measuring the common-mode output voltage from the transceiver, use a high-impedance oscilloscope probe at JMP6-1 with respect to GND2. The common-mode voltage will be observed for both Dominant and Recessive outputs from the transceiver. In this configuration, R3 and R4 in series act as a load resistance in parallel with R2. This creates an effective load resistance of 55 Ohms.

An external common-mode offset voltage may be applied to JMP6-1 with respect to GND2. The ISO 11898-2 CAN standard specifies operation with common-mode offsets in the range from -2V to +7V.

In the plot below, the common-mode output is measured. Channel 1 is the TXD input data from a signal generator, representing 100 kbps data to be transmitted. Channel 2 is the CANH signal, Channel 3 is the CANL signal. Channel 4 shows the common-mode output signal at JMP6-1. In this case, both supplies Vcc1 and Vcc2 were set to 5V. The very small peak-to-peak amplitude of the common-mode signal indicates the well-balanced CANH and CANL outputs will generate very low electromagnetic emissions.

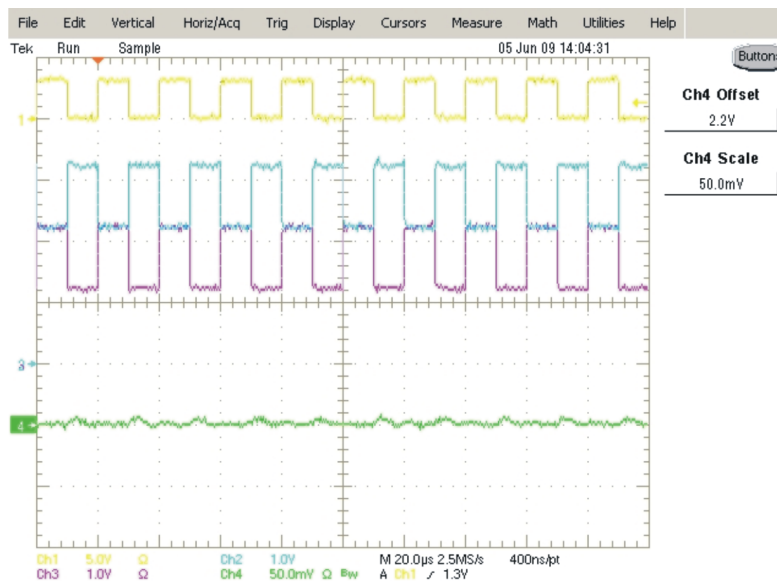

Figure 6. Common-mode Measurement Waveforms

EVALUATION BOARD/KIT IMPORTANT NOTICE

Texas Instruments (TI) provides the enclosed product(s) under the following conditions:

This evaluation board/kit is intended for use for **ENGINEERING DEVELOPMENT, DEMONSTRATION, OR EVALUATION PURPOSES ONLY** and is not considered by TI to be a finished end-product fit for general consumer use. Persons handling the product(s) must have electronics training and observe good engineering practice standards. As such, the goods being provided are not intended to be complete in terms of required design-, marketing-, and/or manufacturing-related protective considerations, including product safety and environmental measures typically found in end products that incorporate such semiconductor components or circuit boards. This evaluation board/kit does not fall within the scope of the European Union directives regarding electromagnetic compatibility, restricted substances (RoHS), recycling (WEEE), FCC, CE or UL, and therefore may not meet the technical requirements of these directives or other related directives.

Should this evaluation board/kit not meet the specifications indicated in the User's Guide, the board/kit may be returned within 30 days from the date of delivery for a full refund. **THE FOREGOING WARRANTY IS THE EXCLUSIVE WARRANTY MADE BY SELLER TO BUYER AND IS IN LIEU OF ALL OTHER WARRANTIES, EXPRESSED, IMPLIED, OR STATUTORY, INCLUDING ANY WARRANTY OF MERCHANTABILITY OR FITNESS FOR ANY PARTICULAR PURPOSE.**

The user assumes all responsibility and liability for proper and safe handling of the goods. Further, the user indemnifies TI from all claims arising from the handling or use of the goods. Due to the open construction of the product, it is the user's responsibility to take any and all appropriate precautions with regard to electrostatic discharge.

EXCEPT TO THE EXTENT OF THE INDEMNITY SET FORTH ABOVE, NEITHER PARTY SHALL BE LIABLE TO THE OTHER FOR ANY INDIRECT, SPECIAL, INCIDENTAL, OR CONSEQUENTIAL DAMAGES.

TI currently deals with a variety of customers for products, and therefore our arrangement with the user **is not exclusive.**

TI assumes **no liability for applications assistance, customer product design, software performance, or infringement of patents or services described herein.**

Please read the User's Guide and, specifically, the Warnings and Restrictions notice in the User's Guide prior to handling the product. This notice contains important safety information about temperatures and voltages. For additional information on TI's environmental and/or safety programs, please contact the TI application engineer or visit www.ti.com/esh.

No license is granted under any patent right or other intellectual property right of TI covering or relating to any machine, process, or combination in which such TI products or services might be or are used.

FCC Warning

This evaluation board/kit is intended for use for **ENGINEERING DEVELOPMENT, DEMONSTRATION, OR EVALUATION PURPOSES ONLY** and is not considered by TI to be a finished end-product fit for general consumer use. It generates, uses, and can radiate radio frequency energy and has not been tested for compliance with the limits of computing devices pursuant to part 15 of FCC rules, which are designed to provide reasonable protection against radio frequency interference. Operation of this equipment in other environments may cause interference with radio communications, in which case the user at his own expense will be required to take whatever measures may be required to correct this interference.

Mailing Address: Texas Instruments, Post Office Box 655303, Dallas, Texas 75265
Copyright © 2009, Texas Instruments Incorporated

EVM WARNINGS AND RESTRICTIONS

It is important to operate this EVM within the input voltage range of 0 V to 5 V and the output voltage range of 0 V to 5 V.

Exceeding the specified input range may cause unexpected operation and/or irreversible damage to the EVM. If there are questions concerning the input range, please contact a TI field representative prior to connecting the input power.

Applying loads outside of the specified output range may result in unintended operation and/or possible permanent damage to the EVM. Please consult the EVM User's Guide prior to connecting any load to the EVM output. If there is uncertainty as to the load specification, please contact a TI field representative.

During normal operation, some circuit components may have case temperatures greater than 60°C. The EVM is designed to operate properly with certain components above 60°C as long as the input and output ranges are maintained. These components include but are not limited to linear regulators, switching transistors, pass transistors, and current sense resistors. These types of devices can be identified using the EVM schematic located in the EVM User's Guide. When placing measurement probes near these devices during operation, please be aware that these devices may be very warm to the touch.

Mailing Address: Texas Instruments, Post Office Box 655303, Dallas, Texas 75265
Copyright © 2009, Texas Instruments Incorporated

IMPORTANT NOTICE

Texas Instruments Incorporated and its subsidiaries (TI) reserve the right to make corrections, modifications, enhancements, improvements, and other changes to its products and services at any time and to discontinue any product or service without notice. Customers should obtain the latest relevant information before placing orders and should verify that such information is current and complete. All products are sold subject to TI's terms and conditions of sale supplied at the time of order acknowledgment.

TI warrants performance of its hardware products to the specifications applicable at the time of sale in accordance with TI's standard warranty. Testing and other quality control techniques are used to the extent TI deems necessary to support this warranty. Except where mandated by government requirements, testing of all parameters of each product is not necessarily performed.

TI assumes no liability for applications assistance or customer product design. Customers are responsible for their products and applications using TI components. To minimize the risks associated with customer products and applications, customers should provide adequate design and operating safeguards.

TI does not warrant or represent that any license, either express or implied, is granted under any TI patent right, copyright, mask work right, or other TI intellectual property right relating to any combination, machine, or process in which TI products or services are used. Information published by TI regarding third-party products or services does not constitute a license from TI to use such products or services or a warranty or endorsement thereof. Use of such information may require a license from a third party under the patents or other intellectual property of the third party, or a license from TI under the patents or other intellectual property of TI.

Reproduction of TI information in TI data books or data sheets is permissible only if reproduction is without alteration and is accompanied by all associated warranties, conditions, limitations, and notices. Reproduction of this information with alteration is an unfair and deceptive business practice. TI is not responsible or liable for such altered documentation. Information of third parties may be subject to additional restrictions.

Resale of TI products or services with statements different from or beyond the parameters stated by TI for that product or service voids all express and any implied warranties for the associated TI product or service and is an unfair and deceptive business practice. TI is not responsible or liable for any such statements.

TI products are not authorized for use in safety-critical applications (such as life support) where a failure of the TI product would reasonably be expected to cause severe personal injury or death, unless officers of the parties have executed an agreement specifically governing such use. Buyers represent that they have all necessary expertise in the safety and regulatory ramifications of their applications, and acknowledge and agree that they are solely responsible for all legal, regulatory and safety-related requirements concerning their products and any use of TI products in such safety-critical applications, notwithstanding any applications-related information or support that may be provided by TI. Further, Buyers must fully indemnify TI and its representatives against any damages arising out of the use of TI products in such safety-critical applications.

TI products are neither designed nor intended for use in military/aerospace applications or environments unless the TI products are specifically designated by TI as military-grade or "enhanced plastic." Only products designated by TI as military-grade meet military specifications. Buyers acknowledge and agree that any such use of TI products which TI has not designated as military-grade is solely at the Buyer's risk, and that they are solely responsible for compliance with all legal and regulatory requirements in connection with such use.

TI products are neither designed nor intended for use in automotive applications or environments unless the specific TI products are designated by TI as compliant with ISO/TS 16949 requirements. Buyers acknowledge and agree that, if they use any non-designated products in automotive applications, TI will not be responsible for any failure to meet such requirements.

Following are URLs where you can obtain information on other Texas Instruments products and application solutions:

Products

Amplifiers	amplifier.ti.com
Data Converters	dataconverter.ti.com
DLP® Products	www.dlp.com
DSP	dsp.ti.com
Clocks and Timers	www.ti.com/clocks
Interface	interface.ti.com
Logic	logic.ti.com
Power Mgmt	power.ti.com
Microcontrollers	microcontroller.ti.com
RFID	www.ti-rfid.com
RF/IF and ZigBee® Solutions	www.ti.com/lprf

Applications

Audio	www.ti.com/audio
Automotive	www.ti.com/automotive
Broadband	www.ti.com/broadband
Digital Control	www.ti.com/digitalcontrol
Medical	www.ti.com/medical
Military	www.ti.com/military
Optical Networking	www.ti.com/opticalnetwork
Security	www.ti.com/security
Telephony	www.ti.com/telephony
Video & Imaging	www.ti.com/video
Wireless	www.ti.com/wireless

Mailing Address: Texas Instruments, Post Office Box 655303, Dallas, Texas 75265
Copyright © 2009, Texas Instruments Incorporated