

3 Phase IGBT Isolated Multi-tap Flyback Power Supply
3 independent top supplies, 1 shared bottom supply

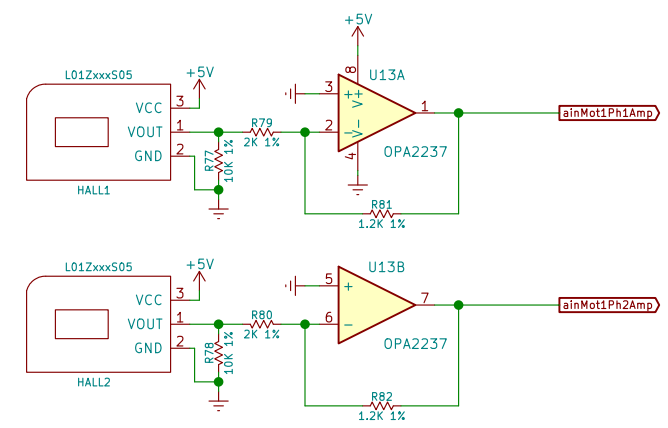

Motor Phase Current Sensors

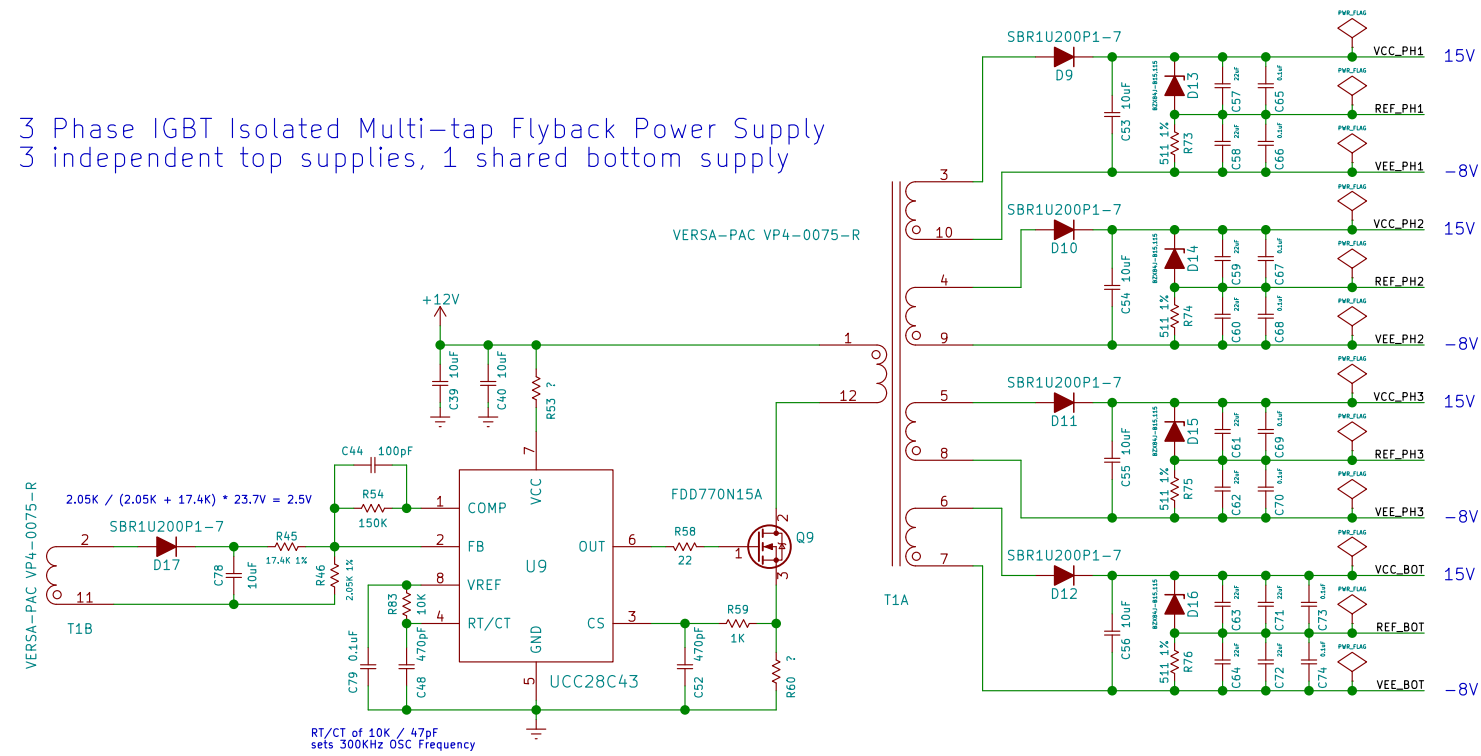
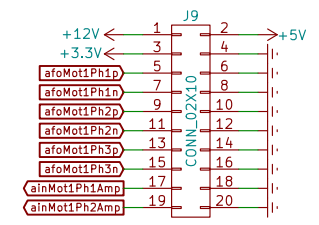
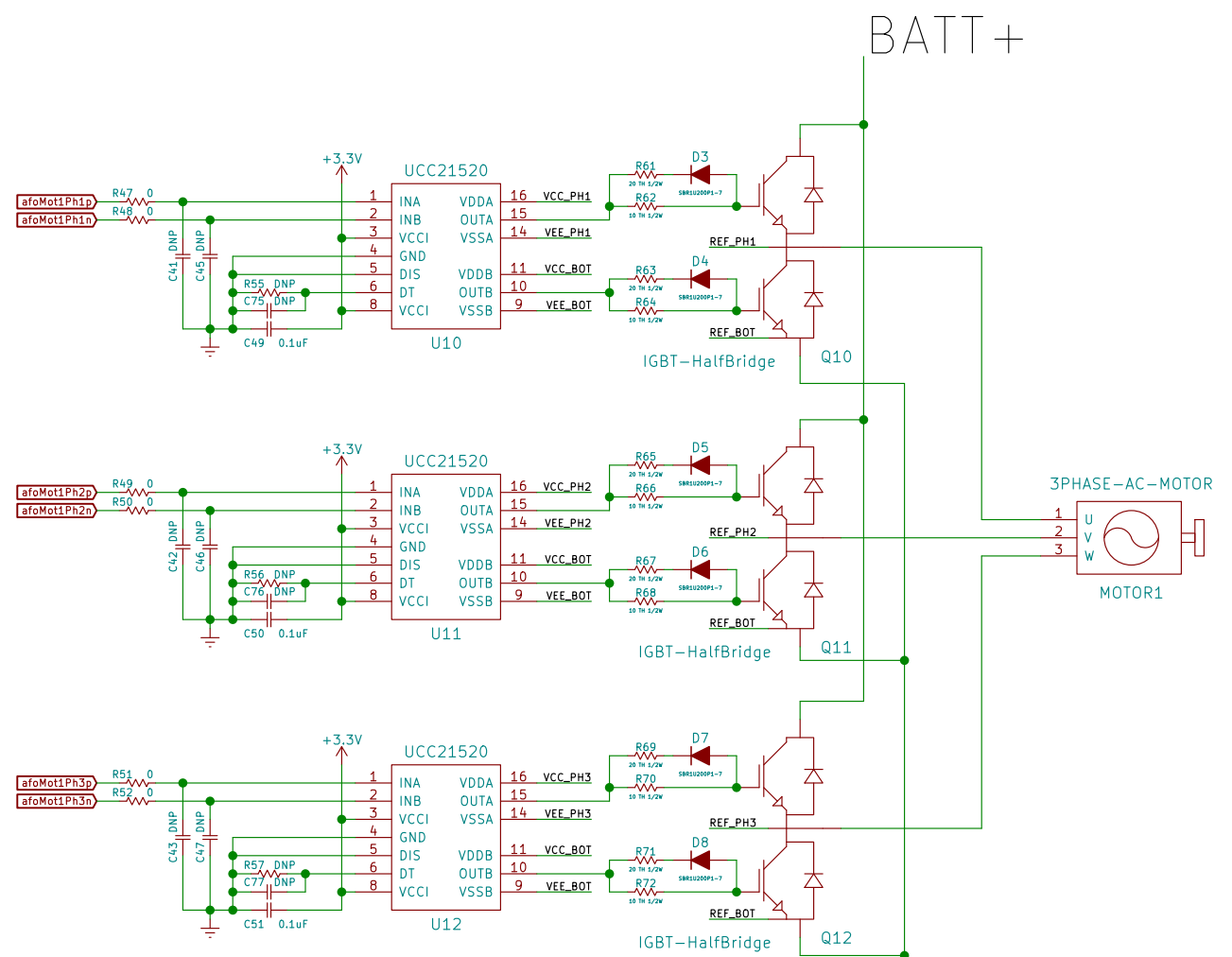

Controller Connector.
Only used if separate PCBs.

Isolated IGBT Drivers

Sheet: /Motor1 Driver/ File: EvaDrive-Motor1.sch		
Title:		
Size: A3	Date:	Rev:
KiCad E.D.A. kicad 4.0.4+e1-630848ubuntu16.04.1-stable		Id: 4/4