

VinMin = 10.0V
 VinMax = 30.0V
 Vout = 15.0V
 Iout = 10.0A

Device = LM5176PWPR
 Topology = Buck_Boost
 Created = 2023-04-26 10:06:10.740
 BOM Cost = \$12.43
 BOM Count = 43
 Total Pd = 5.24W

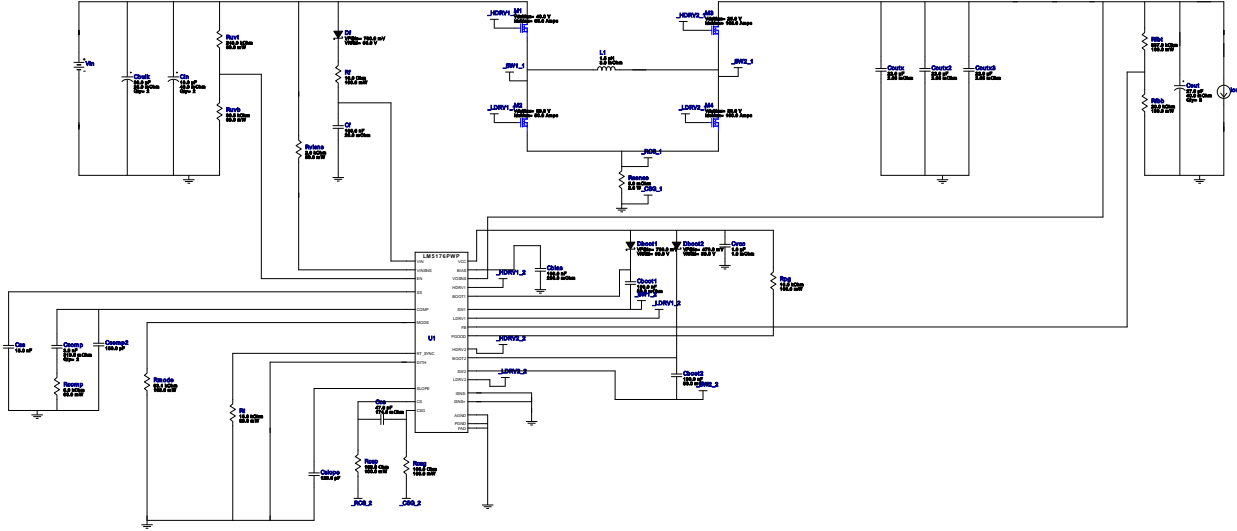















WEBENCH® Design Report

Design : 8 LM5176PWPR
 LM5176PWPR 10V-30V to 15.00V @ 10A



Electrical BOM

Name	Manufacturer	Part Number	Properties	Qty	Price	Footprint
Cbias	AVX	08053C104KAT2A Series= X7R	Cap= 100.0 nF ESR= 280.0 mOhm VDC= 25.0 V IRMS= 0.0 A	1	\$0.01	0805 7 mm ²
Cboot1	AVX	06033C104KAT2A Series= X7R	Cap= 100.0 nF ESR= 50.0 mOhm VDC= 25.0 V IRMS= 0.0 A	1	\$0.01	0603 5 mm ²
Cboot2	AVX	06033C104KAT2A Series= X7R	Cap= 100.0 nF ESR= 50.0 mOhm VDC= 25.0 V IRMS= 0.0 A	1	\$0.01	0603 5 mm ²
Cbulk	Panasonic	50SVPF39M Series= SVPF	Cap= 39.0 uF ESR= 25.0 mOhm VDC= 50.0 V IRMS= 3.8 A	2	\$1.15	 CAPSMT_62_E12 106 mm ²
Ccomp	Kemet	C0805C392K5RACTU Series= X7R	Cap= 3.9 nF ESR= 310.0 mOhm VDC= 50.0 V IRMS= 350.0 mA	2	\$0.01	0805 7 mm ²
Ccomp2	Taiyo Yuden	UMK105CG151JV-F Series= C0G/NP0	Cap= 150.0 pF VDC= 50.0 V IRMS= 0.0 A	1	\$0.01	0402 3 mm ²
Ccs	AVX	06035A470JAT2A Series= C0G/NP0	Cap= 47.0 pF ESR= 174.0 mOhm VDC= 50.0 V IRMS= 0.0 A	1	\$0.01	0603 5 mm ²
Cf	TDK	CGA3E2X7R1H104K080AA Series= X7R	Cap= 100.0 nF ESR= 29.6 mOhm VDC= 50.0 V IRMS= 971.99 mA	1	\$0.01	0603 5 mm ²

Name	Manufacturer	Part Number	Properties	Qty	Price	Footprint
Cin	Panasonic	50SVPF10M Series= SVPF	Cap= 10.0 uF ESR= 40.0 mOhm VDC= 50.0 V IRMS= 2.5 A	2	\$0.59	 CAPSMT_62_F61 74 mm ²
Cout	Panasonic	25SVPF27MX Series= SVPF	Cap= 27.0 uF ESR= 40.0 mOhm VDC= 25.0 V IRMS= 2.45 A	3	\$0.47	 CAPSMT_62_E61 53 mm ²
Coutx	TDK	C2012X5R1V226M125AC Series= X5R	Cap= 22.0 uF ESR= 2.05 mOhm VDC= 35.0 V IRMS= 4.5559 A	1	\$0.31	 0805 7 mm ²
Coutx2	TDK	C2012X5R1V226M125AC Series= X5R	Cap= 22.0 uF ESR= 2.05 mOhm VDC= 35.0 V IRMS= 4.5559 A	1	\$0.31	 0805 7 mm ²
Coutx3	TDK	C2012X5R1V226M125AC Series= X5R	Cap= 22.0 uF ESR= 2.05 mOhm VDC= 35.0 V IRMS= 4.5559 A	1	\$0.31	 0805 7 mm ²
Cslope	Samsung Electro-Mechanics	CL10C121JB8NNNC Series= C0G/NP0	Cap= 120.0 pF VDC= 50.0 V IRMS= 0.0 A	1	\$0.01	 0603 5 mm ²
Css	Kemet	C0603C153J3GACTU Series= C0G/NP0	Cap= 15.0 nF VDC= 25.0 V IRMS= 0.0 A	1	\$0.09	 0603 5 mm ²
Cvcc	Taiyo Yuden	EMK107B7105KA-T Series= X7R	Cap= 1.0 uF ESR= 1.0 mOhm VDC= 16.0 V IRMS= 0.0 A	1	\$0.01	 0603 5 mm ²
Dboot1	Diodes Inc.	B260A-13-F	VF@Io= 700.0 mV VRRM= 60.0 V	1	\$0.10	 SMA 37 mm ²
Dboot2	Torex USA Corporation	XBS053V15R-G	VF@Io= 470.0 mV VRRM= 30.0 V	1	\$0.15	 SOD-523 5 mm ²
Df	Diodes Inc.	B260A-13-F	VF@Io= 700.0 mV VRRM= 60.0 V	1	\$0.10	 SMA 37 mm ²
L1	Coilcraft	XAL1060-152MEB	L= 1.5 uH 3.0 mOhm	1	\$1.30	 XAL1060 160 mm ²
M1	Texas Instruments	CSD18514Q5A	VdsMax= 40.0 V IdsMax= 50.0 Amps	1	\$0.24	 TRANS_NexFET_Q5A 55 mm ²
M2	Texas Instruments	CSD18537NQ5A	VdsMax= 60.0 V IdsMax= 50.0 Amps	1	\$0.26	 TRANS_NexFET_Q5A 55 mm ²
M3	Texas Instruments	CSD16321Q5	VdsMax= 25.0 V IdsMax= 100.0 Amps	1	\$0.54	 TRANS_NexFET_Q5 55 mm ²
M4	Texas Instruments	CSD17573Q5B	VdsMax= 30.0 V IdsMax= 100.0 Amps	1	\$0.52	 DNK0008A 56 mm ²
Rcomp	Vishay-Dale	CRCW04025K90FKED Series= CRCW..e3	Res= 5.9 kOhm Power= 63.0 mW Tolerance= 1.0%	1	\$0.01	 0402 3 mm ²

Name	Manufacturer	Part Number	Properties	Qty	Price	Footprint
Rcsg	Vishay-Dale	CRCW0603100RFKEA Series= CRCW..e3	Res= 100.0 Ohm Power= 100.0 mW Tolerance= 1.0%	1	\$0.01	0603 5 mm ²
Rcsp	Vishay-Dale	CRCW0603100RFKEA Series= CRCW..e3	Res= 100.0 Ohm Power= 100.0 mW Tolerance= 1.0%	1	\$0.01	0603 5 mm ²
Rf	Yageo	RC0603FR-0710RL Series= ?	Res= 10.0 Ohm Power= 100.0 mW Tolerance= 1.0%	1	\$0.01	0603 5 mm ²
Rfbb	Yageo	RC0603FR-0720KL Series= ?	Res= 20.0 kOhm Power= 100.0 mW Tolerance= 1.0%	1	\$0.01	0603 5 mm ²
Rfbt	Yageo	RC0603FR-07357KL Series= ?	Res= 357.0 kOhm Power= 100.0 mW Tolerance= 1.0%	1	\$0.01	0603 5 mm ²
Rmode	Yageo	RC0603FR-0793K1L Series= ?	Res= 93.1 kOhm Power= 100.0 mW Tolerance= 1.0%	1	\$0.01	0603 5 mm ²
Rpg	Yageo	RC0603FR-0710KL Series= ?	Res= 10.0 kOhm Power= 100.0 mW Tolerance= 1.0%	1	\$0.01	0603 5 mm ²
Rsense	Stackpole Electronics Inc	CSNL2512FT5L00 Series= ?	Res= 5.0 mOhm Power= 2.0 W Tolerance= 1.0%	1	\$0.19	2512 43 mm ²
Rt	Vishay-Dale	CRCW040215K8FKED Series= CRCW..e3	Res= 15.8 kOhm Power= 63.0 mW Tolerance= 1.0%	1	\$0.01	0402 3 mm ²
Ruvb	Yageo	AC0402FR-0736K5L Series= ?	Res= 36.5 kOhm Power= 63.0 mW Tolerance= 1.0%	1	\$0.01	0402 3 mm ²
Ruvt	Vishay-Dale	CRCW0402249KFKED Series= CRCW..e3	Res= 249.0 kOhm Power= 63.0 mW Tolerance= 1.0%	1	\$0.01	0402 3 mm ²
Rvisns	Vishay-Dale	CRCW04022K00FKED Series= CRCW..e3	Res= 2.0 kOhm Power= 63.0 mW Tolerance= 1.0%	1	\$0.01	0402 3 mm ²
U1	Texas Instruments	LM5176PWPR	Switcher	1	\$2.90	PWP0028C_N 98 mm ²

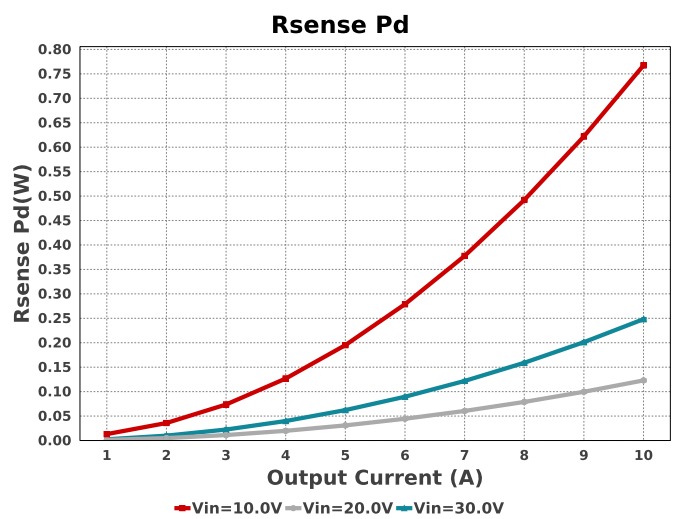
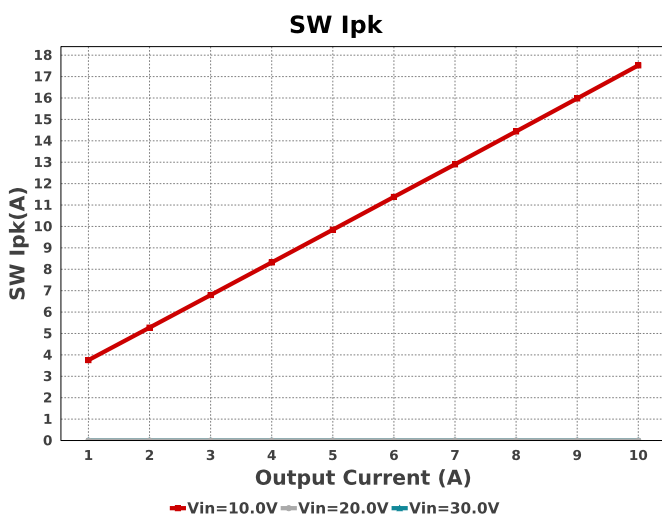

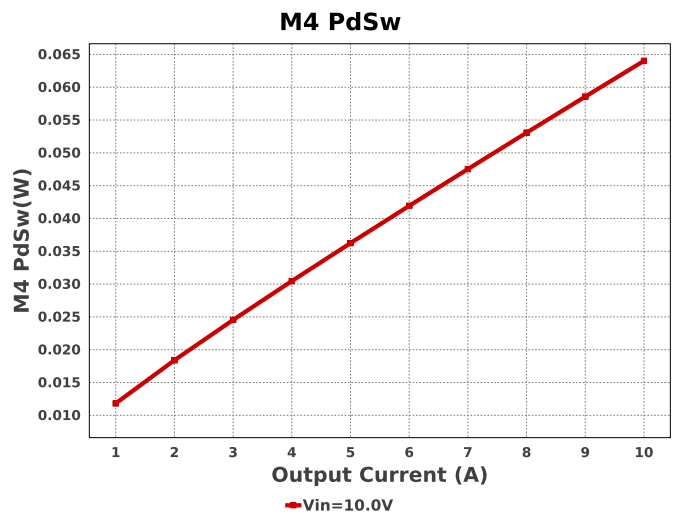
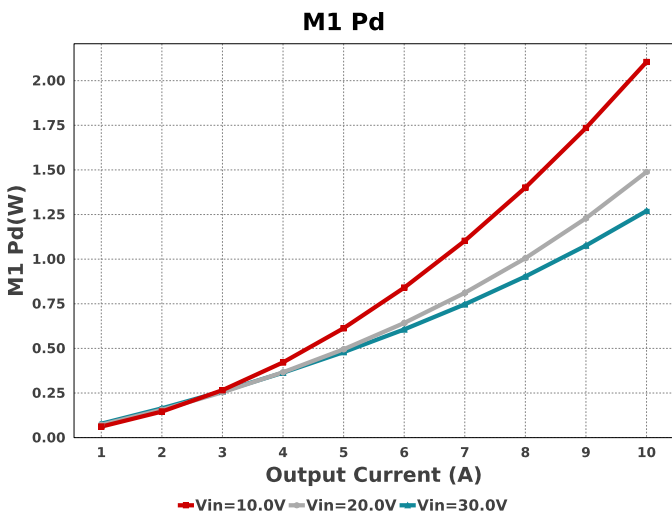
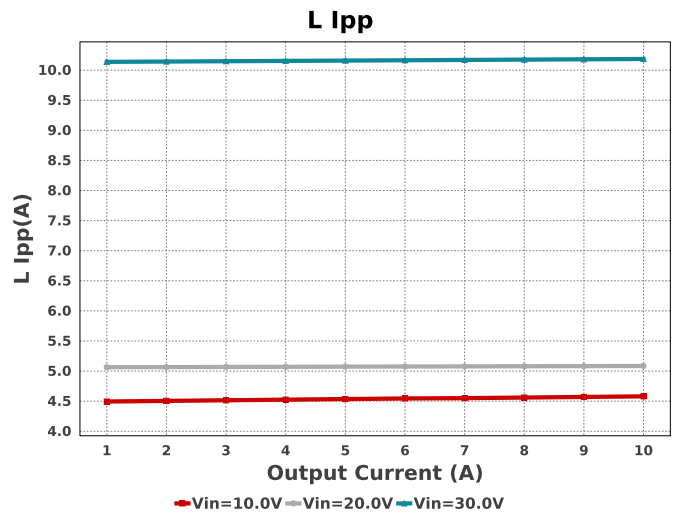
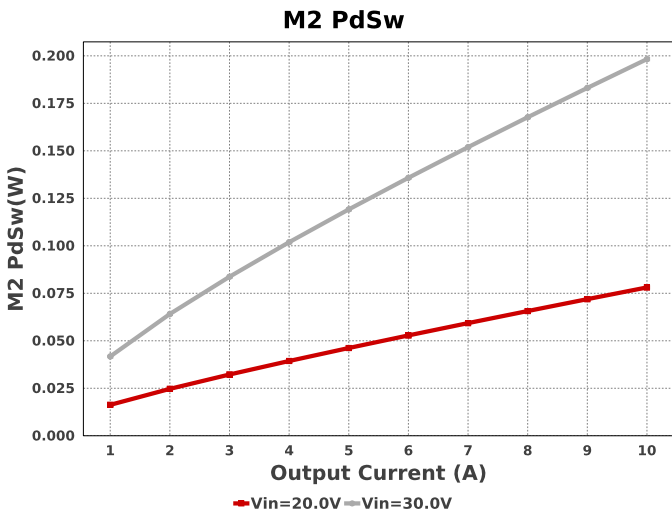
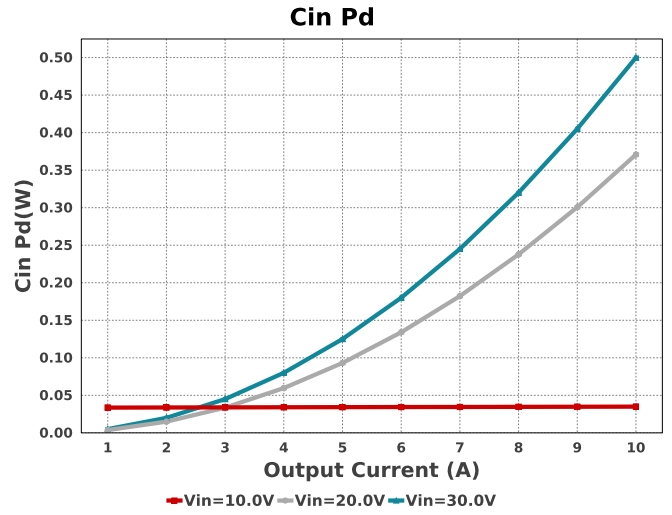
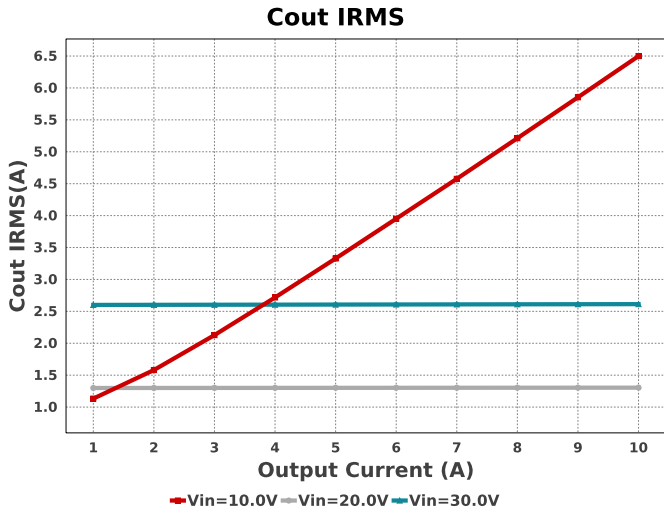

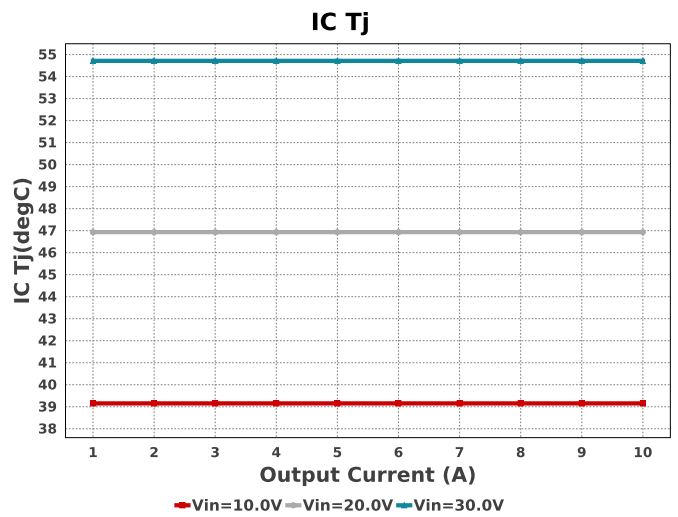
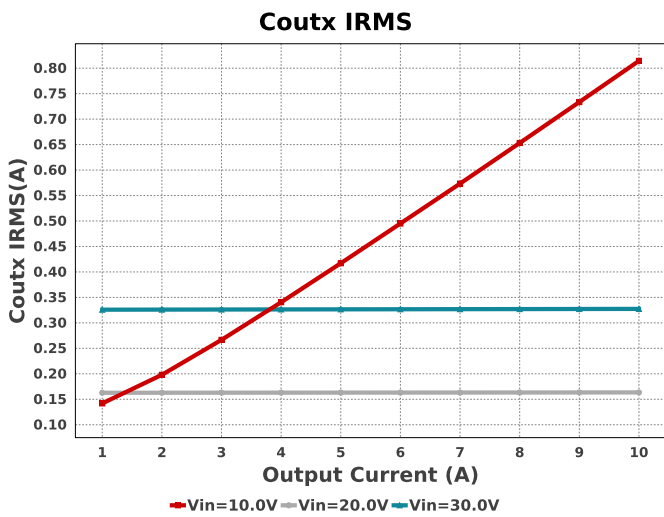
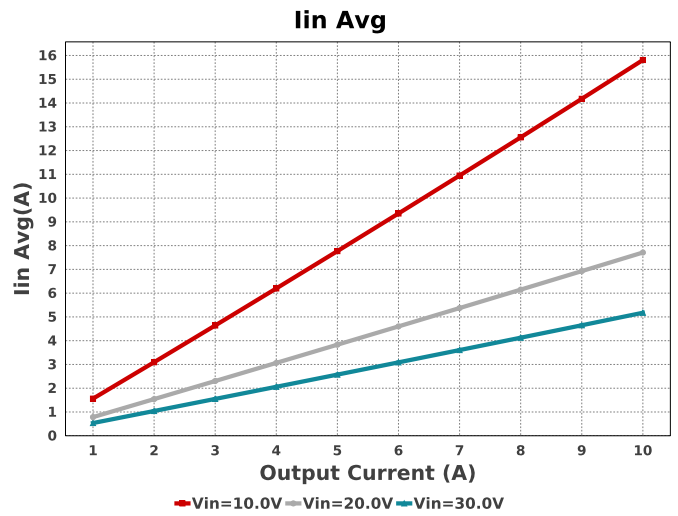
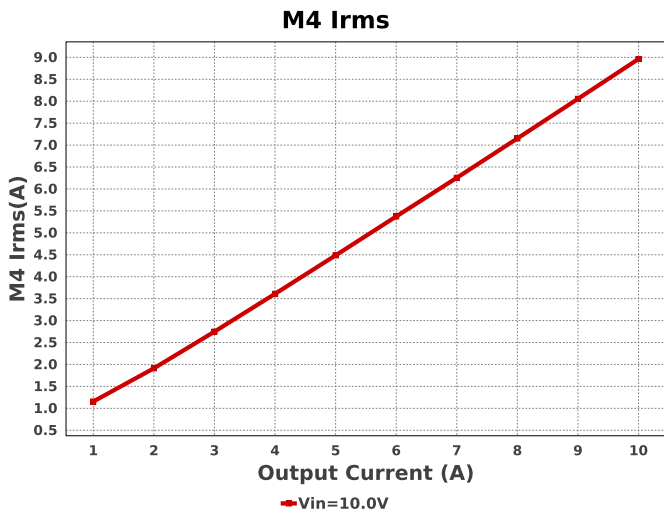
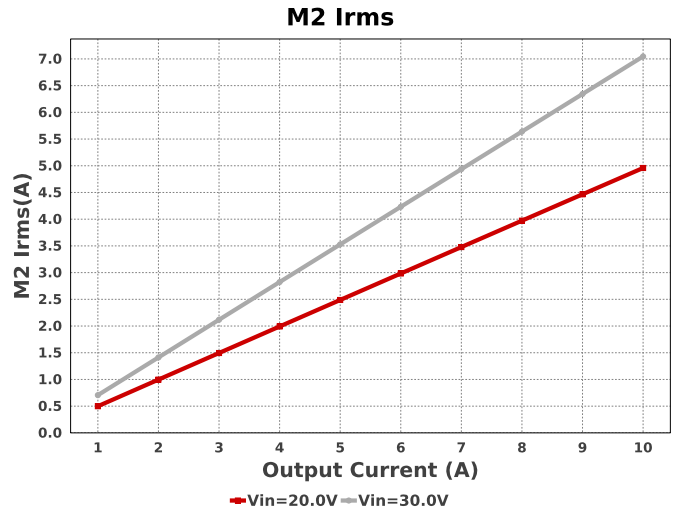
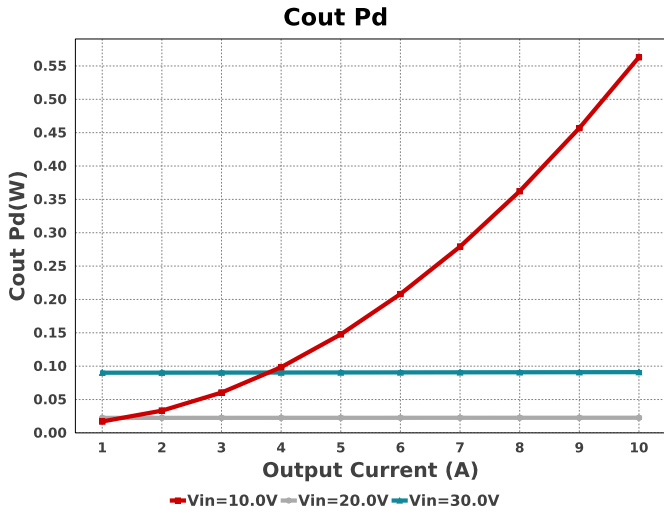

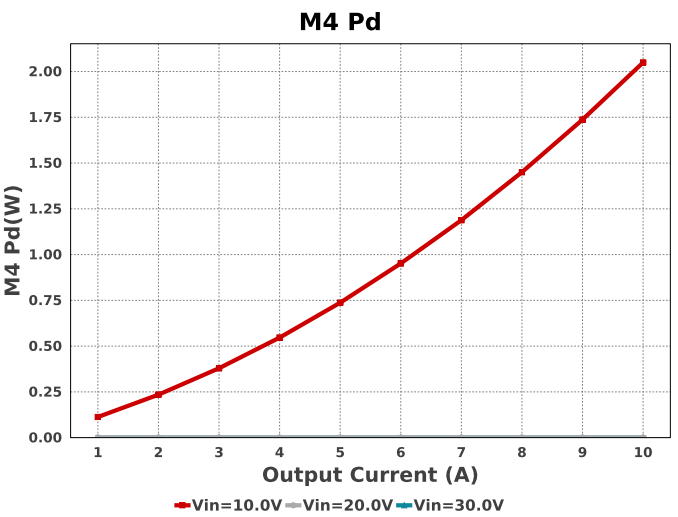
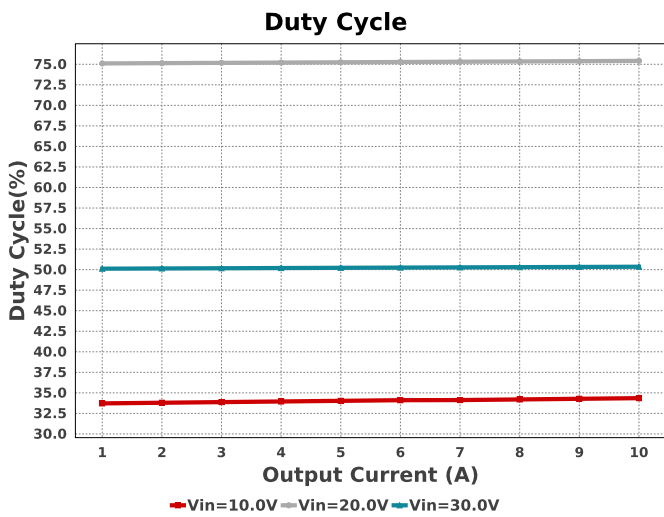
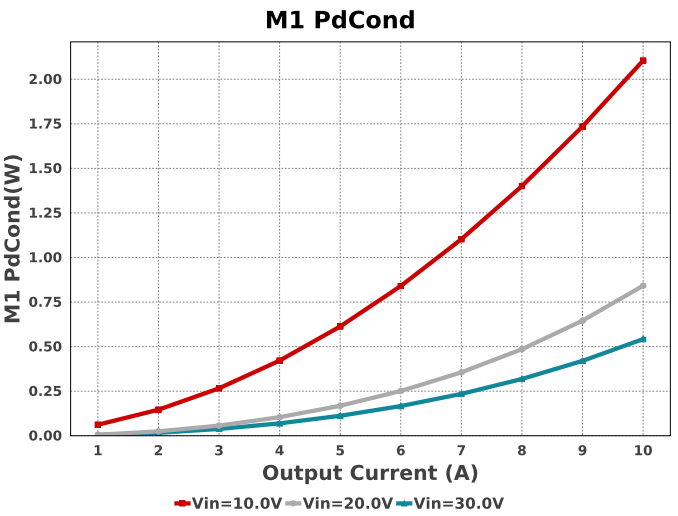
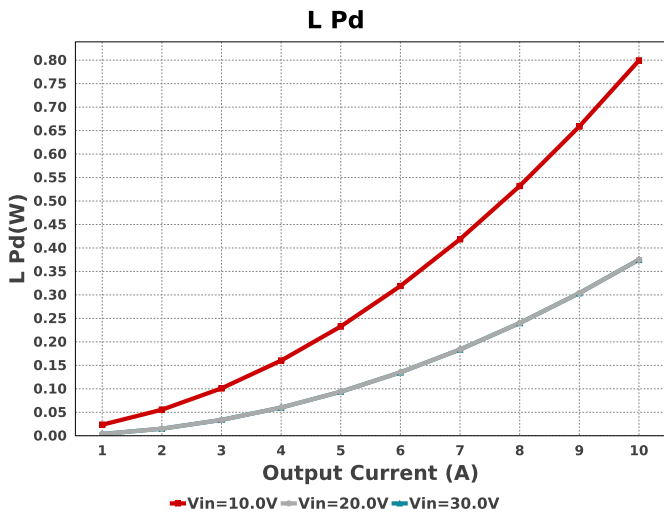
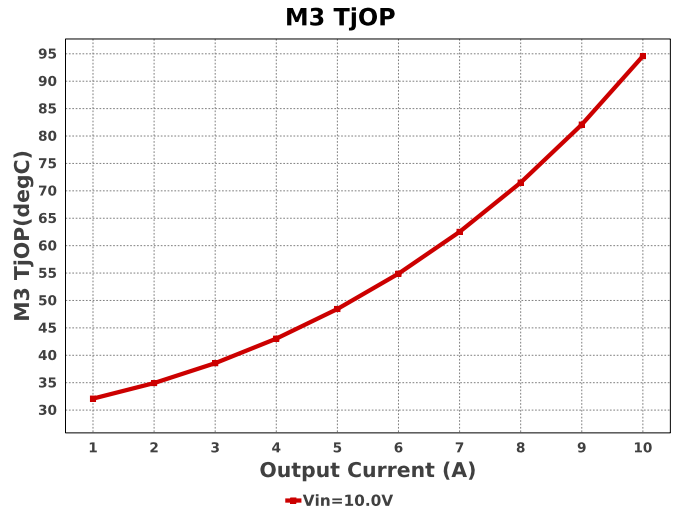
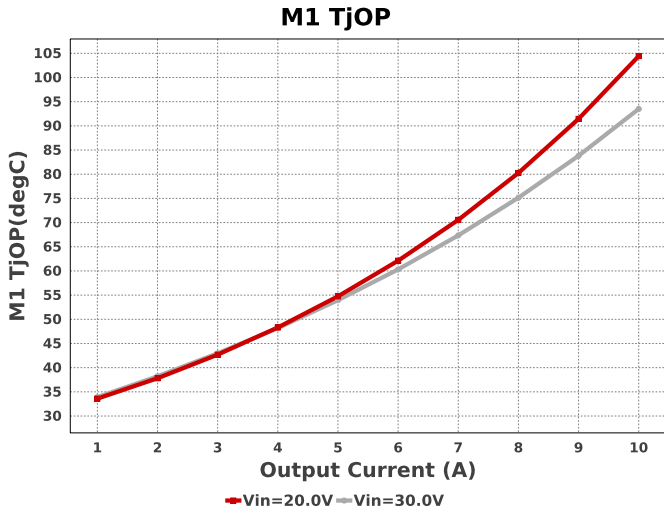

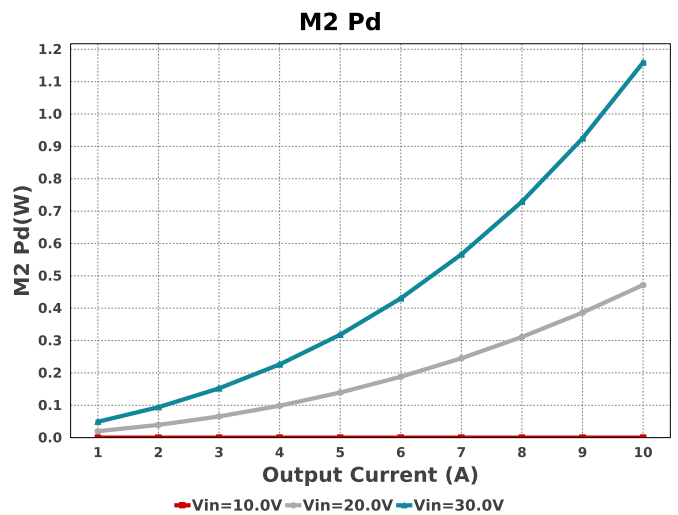
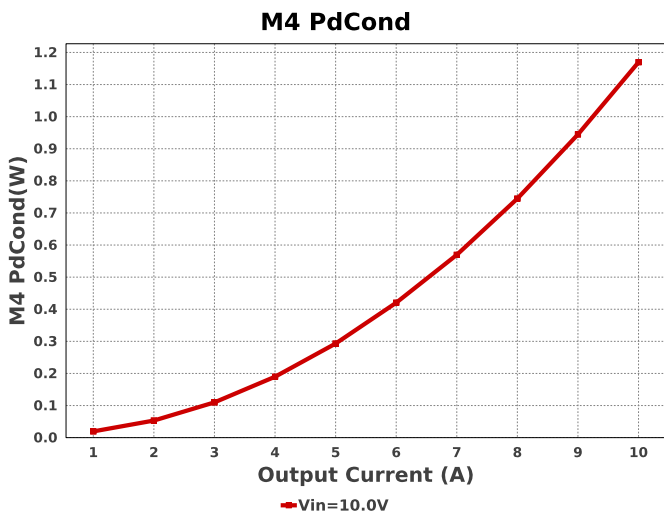
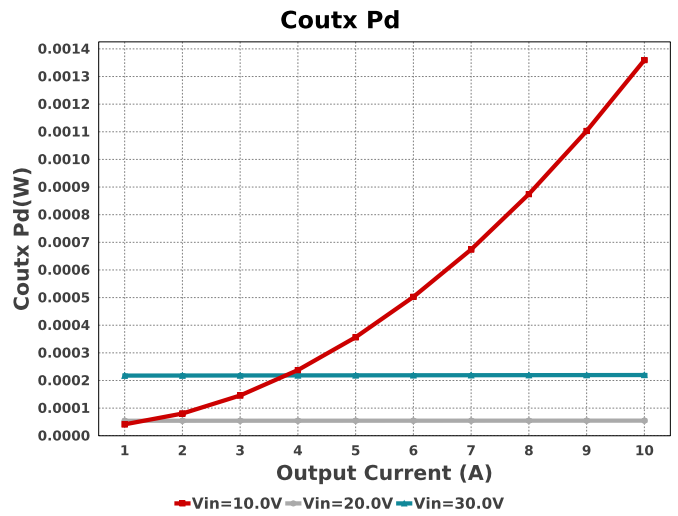
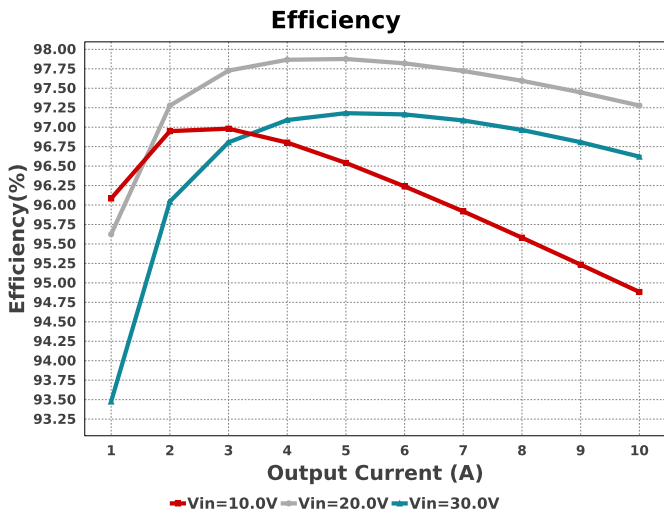
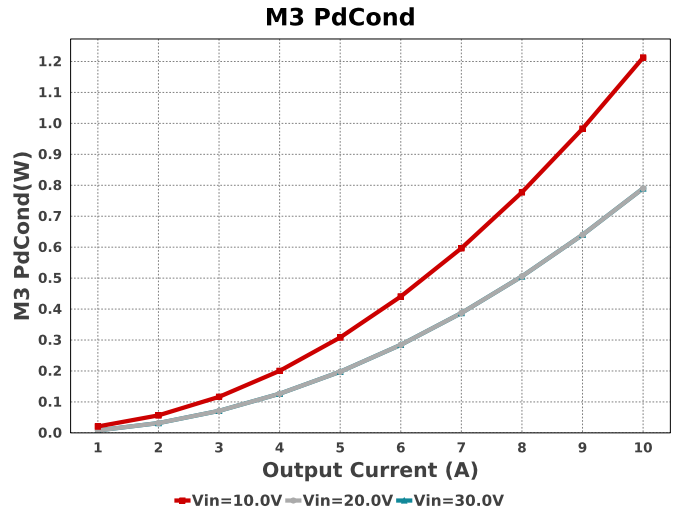
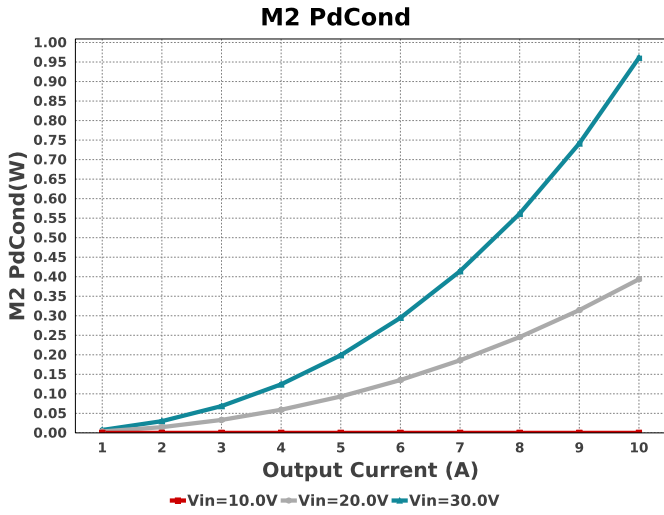

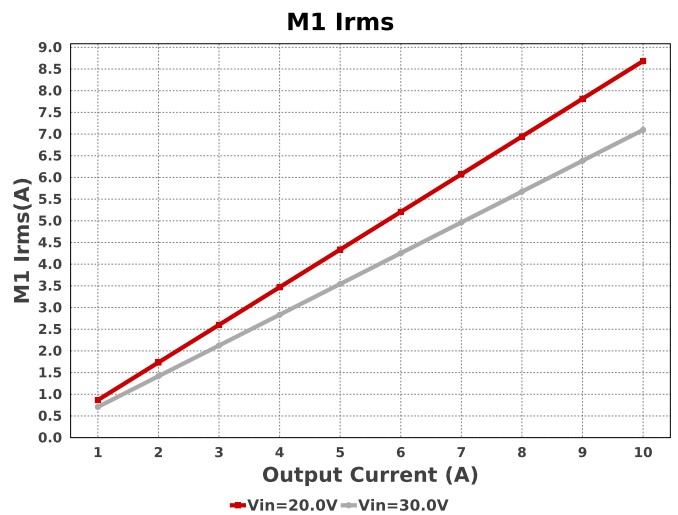
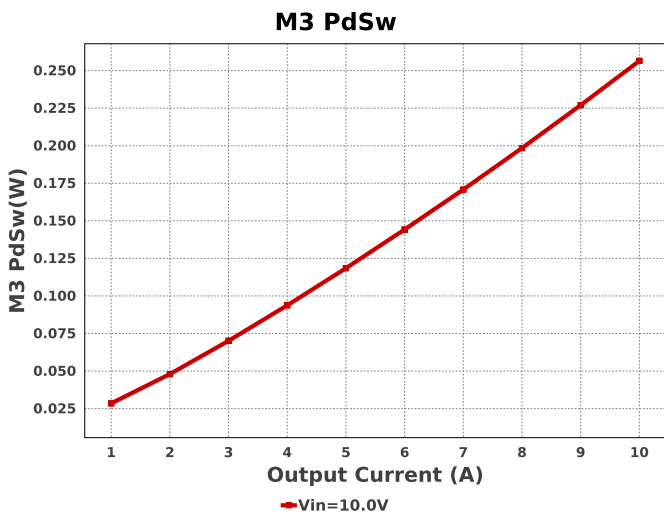
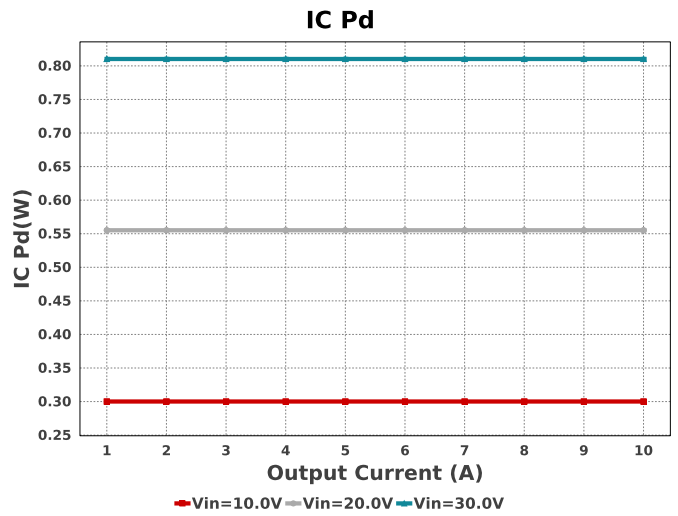
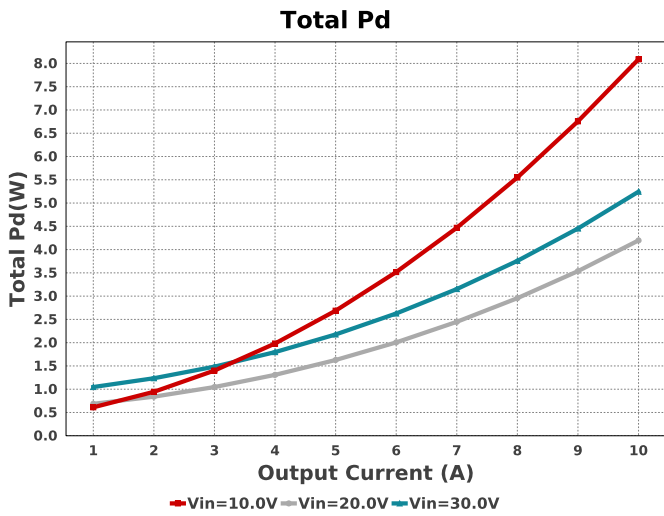
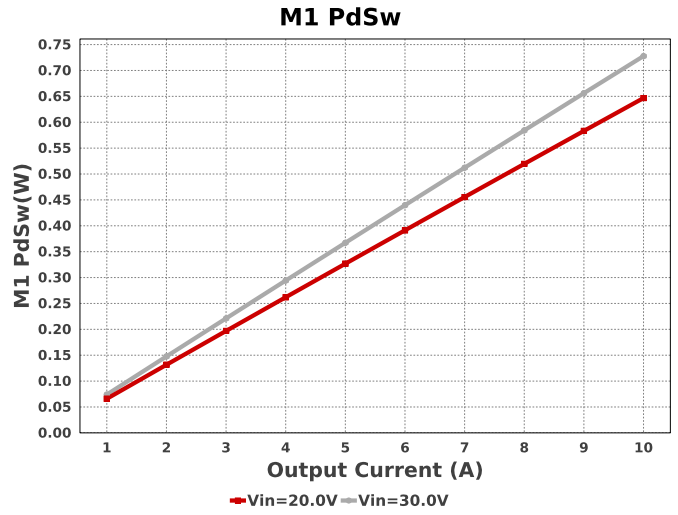
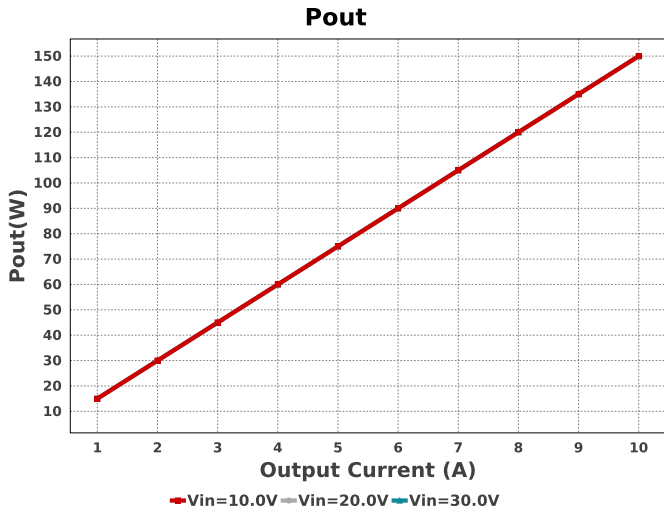

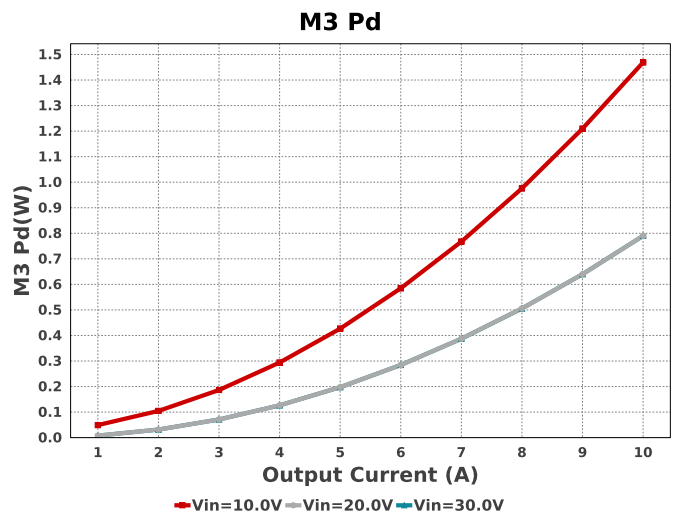
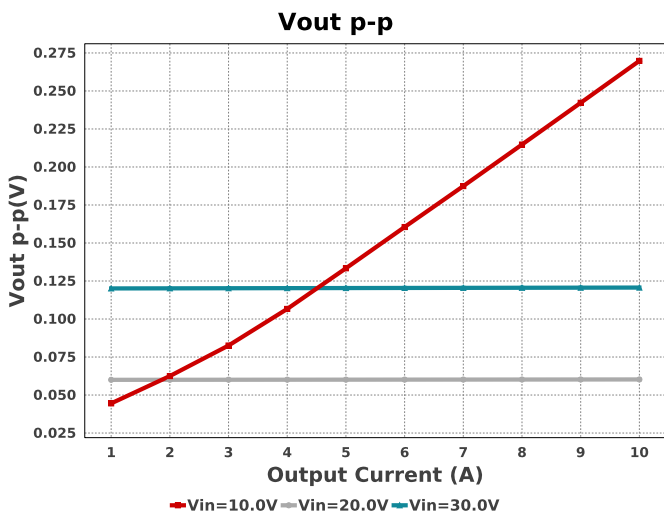
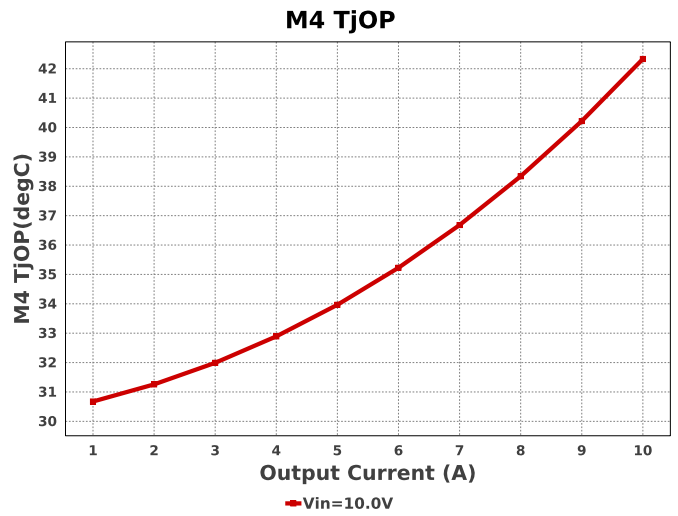
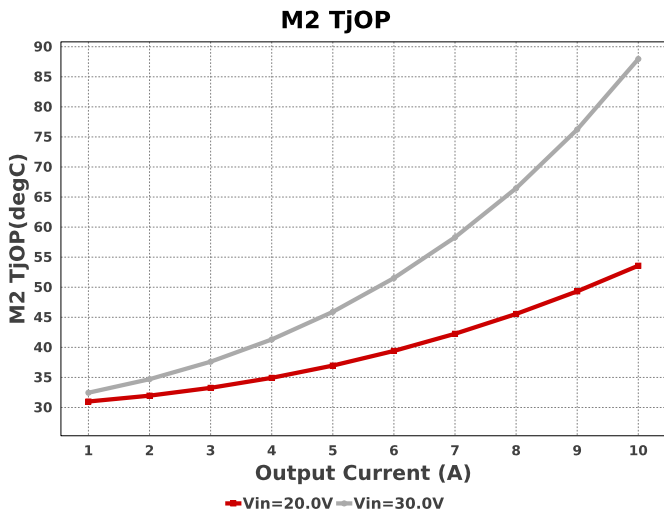
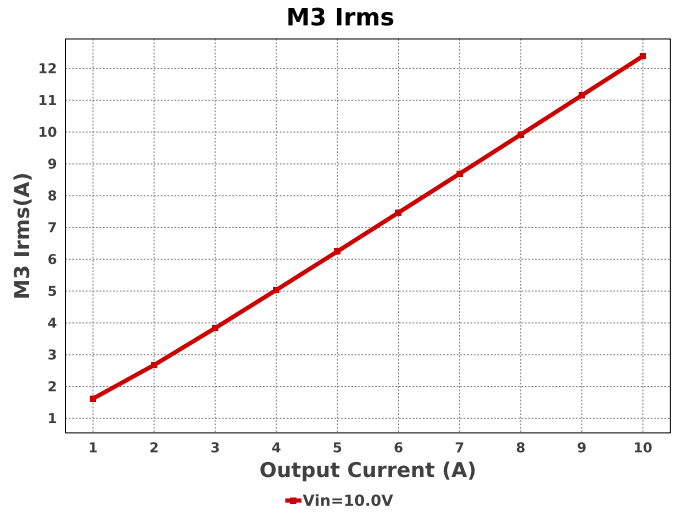
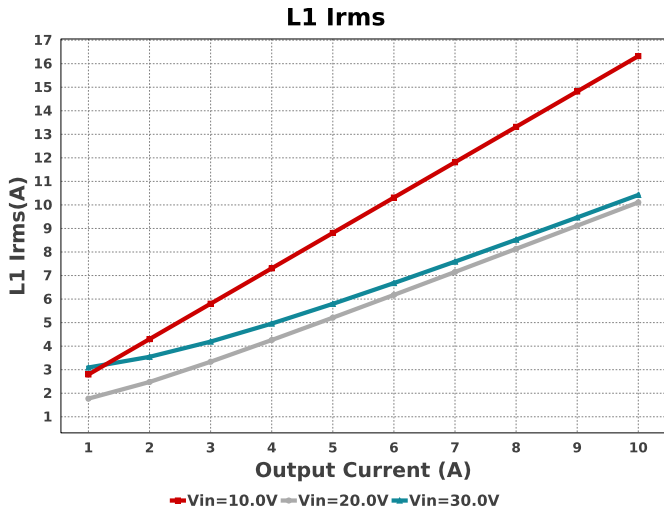

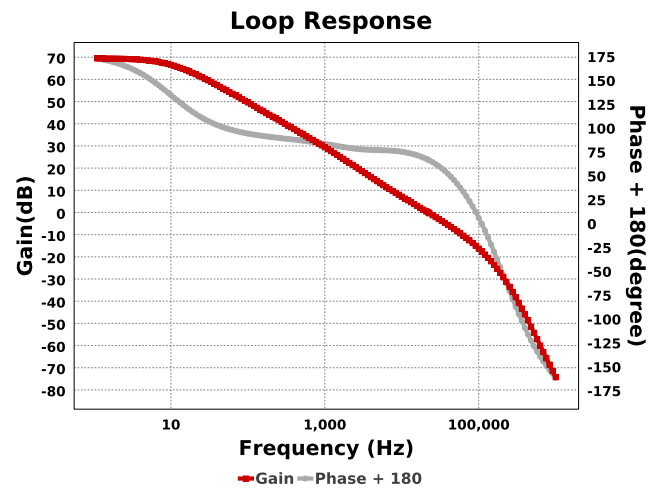
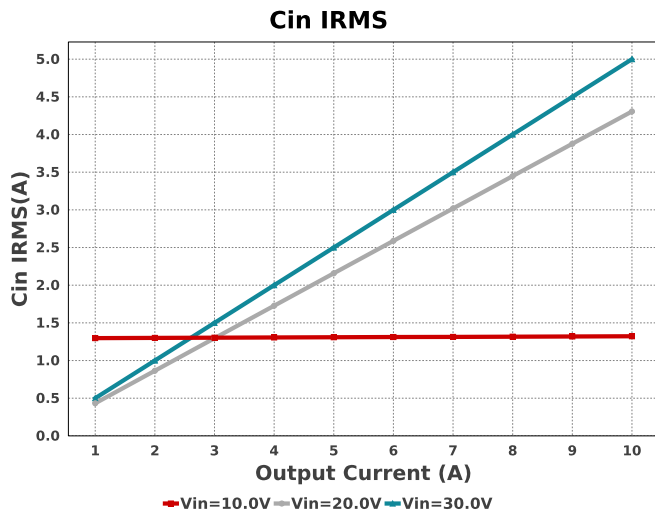

Operating Values

#	Name	Value	Category	Description
1.	Cin IRMS	5.0 A	Capacitor	Input capacitor RMS ripple current
2.	Cin Pd	499.97 mW	Capacitor	Input capacitor power dissipation
3.	Cout IRMS	2.614 A	Capacitor	Output capacitor RMS ripple current
4.	Cout Pd	91.115 mW	Capacitor	Output capacitor power dissipation
5.	Coutx IRMS	326.203 mA	Capacitor	Output capacitor_x RMS ripple current
6.	Coutx Pd	218.14 μ W	Capacitor	Output capacitor_x power loss
7.	IC Pd	810.28 mW	IC	IC power dissipation
8.	IC Tj	54.713 degC	IC	IC junction temperature
9.	IC Tolerance	0.0 V	IC	IC Feedback Tolerance
10.	ICThetaJA	30.5 degC/W	IC	IC junction-to-ambient thermal resistance
11.	Iin Avg	5.175 A	IC	Average input current
12.	L Ipp	10.186 A	Inductor	Peak-to-peak inductor ripple current
13.	L Pd	375.0 mW	Inductor	Inductor power dissipation
14.	L1 Irms	10.423 A	Inductor	Inductor ripple current
15.	M1 Irms	7.096 A	Mosfet	MOSFET RMS ripple current
16.	M1 Pd	1.27 W	Mosfet	MOSFET power dissipation
17.	M1 PdCond	542.24 mW	Mosfet	M1 MOSFET conduction losses
18.	M1 PdSw	727.74 mW	Mosfet	M1 MOSFET switching losses
19.	M1 Rdson	7.9 mOhm	Mosfet	Drain-Source On-resistance
20.	M1 ThetaJA	50.0 degC/W	Mosfet	MOSFET junction-to-ambient thermal resistance
21.	M1 TjOP	93.499 degC	Mosfet	MOSFET junction temperature
22.	M2 Irms	7.046 A	Mosfet	MOSFET RMS ripple current
23.	M2 Pd	1.159 W	Mosfet	MOSFET power dissipation
24.	M2 PdCond	960.97 mW	Mosfet	M2 MOSFET conduction losses
25.	M2 PdSw	198.26 mW	Mosfet	M2 MOSFET switching losses
26.	M2 Rdson	14.56 mOhm	Mosfet	Drain-Source On-resistance
27.	M2 ThetaJA	50.0 degC/W	Mosfet	MOSFET junction-to-ambient thermal resistance
28.	M2 TjOP	87.961 degC	Mosfet	MOSFET junction temperature
29.	M3 Pd	790.0 mW	Mosfet	M3 MOSFET total power dissipation
30.	M3 PdCond	790.0 mW	Mosfet	M3 MOSFET conduction losses
31.	M4 Pd	100.0 pW	Mosfet	M4 MOSFET total power dissipation
32.	Cin Pd	499.97 mW	Power	Input capacitor power dissipation
33.	Cout Pd	91.115 mW	Power	Output capacitor power dissipation
34.	Coutx Pd	218.14 μ W	Power	Output capacitor_x power loss
35.	IC Pd	810.28 mW	Power	IC power dissipation
36.	L Pd	375.0 mW	Power	Inductor power dissipation
37.	M1 Pd	1.27 W	Power	MOSFET power dissipation
38.	M1 PdCond	542.24 mW	Power	M1 MOSFET conduction losses
39.	M1 PdSw	727.74 mW	Power	M1 MOSFET switching losses
40.	M2 Pd	1.159 W	Power	MOSFET power dissipation
41.	M2 PdCond	960.97 mW	Power	M2 MOSFET conduction losses
42.	M2 PdSw	198.26 mW	Power	M2 MOSFET switching losses
43.	M3 Pd	790.0 mW	Power	M3 MOSFET total power dissipation
44.	M3 PdCond	790.0 mW	Power	M3 MOSFET conduction losses
45.	M4 Pd	100.0 pW	Power	M4 MOSFET total power dissipation
46.	Rsense Pd	248.23 mW	Power	LED Current Rns Power Dissipation
47.	Total Pd	5.244 W	Power	Total Power Dissipation
48.	Rsense Pd	248.23 mW	Resistor	LED Current Rns Power Dissipation
49.	BOM Count	43	System	Total Design BOM count
50.	Cross Freq	21.945 kHz	Information	Bode plot crossover frequency

#	Name	Value	Category	Description
51.	Duty Cycle	50.354 %	System Information	Duty cycle
52.	Efficiency	96.622 %	System Information	Steady state efficiency
53.	FootPrint	1.246 k mm ²	System Information	Total Foot Print Area of BOM components
54.	Frequency	494.364 kHz	System Information	Switching frequency
55.	Gain Marg	-17.641 dB	System Information	Bode Plot Gain Margin
56.	Iout	10.0 A	System Information	Iout operating point
57.	Low Freq Gain	69.44 dB	System Information	Gain at 1Hz
58.	Mode	CCM	System Information	Conduction Mode
59.	Operating Topology	Buck	System Information	The current operating topology of the device
60.	Phase Marg	67.712 deg	System Information	Bode Plot Phase Margin
61.	Pout	150.0 W	System Information	Total output power
62.	SW Ipk	0.0 A	System Information	Peak switch current
63.	Total BOM	\$12.43	System Information	Total BOM Cost
64.	Vin	30.0 V	System Information	Vin operating point
65.	Vout	15.0 V	System Information	Operational Output Voltage
66.	Vout Actual	15.08 V	System Information	Vout Actual calculated based on selected voltage divider resistors
67.	Vout Tolerance	1.913 %	System Information	Vout Tolerance based on IC Tolerance (no load) and voltage divider resistors if applicable
68.	Vout p-p	120.741 mV	System Information	Peak-to-peak output ripple voltage

Design Inputs

Name	Value	Description
Iout	10.0	Maximum Output Current
SoftStart	2.0 ms	Soft Start Time (ms)
VinMax	30.0	Maximum input voltage
VinMin	10.0	Minimum input voltage
Vout	15.0	Output Voltage
base_pn	LM5176	Base Product Number
source	DC	Input Source Type
Ta	30.0	Ambient temperature
UserFsw	500.0 k	Customer Selected Frequency

WEBENCH® Assembly

Component Testing

Some published data on components in datasheets such as Capacitor ESR and Inductor DC resistance is based on conservative values that will guarantee that the components always exceed the specification. For design purposes it is usually better to work with typical values. Since this data is not always available it is a good practice to measure the Capacitance and ESR values of C_{in} and C_{out} , and the inductance and DC resistance of L1 before assembly of the board. Any large discrepancies in values should be electrically simulated in WEBENCH to check for instabilities and thermally simulated in WebTHERM to make sure critical temperatures are not exceeded.

Soldering Component to Board

If board assembly is done in house it is best to tack down one terminal of a component on the board then solder the other terminal. For surface mount parts with large tabs, such as the DPAK, the tab on the back of the package should be pre-tinned with solder, then tacked into place by one of the pins. To solder the tab down to the board place the iron down on the board while resting against the tab, heating both surfaces simultaneously. Apply light pressure to the top of the plastic case until the solder flows around the part and the part is flush with the PCB. If the solder is not flowing around the board you may need a higher wattage iron (generally 25W to 30W is enough).

Initial Startup of Circuit

It is best to initially power up the board by setting the input supply voltage to the lowest operating input voltage 10.0V and set the input supply's current limit to zero. With the input supply off connect up the input supply to V_{in} and GND. Connect a digital volt meter and a load if needed to set the minimum load of the design from V_{out} and GND. Turn on the input supply and slowly turn up the current limit on the input supply. If the voltage starts to rise on the input supply continue increasing the input supply current limit while watching the output voltage. If the current increases on the input supply, but the voltage remains near zero, then there may be a short or a component misplaced on the board. Power down the board and visually inspect for solder bridges and recheck the diode and capacitor polarities. Once the power supply circuit is operational then more extensive testing may include full load testing, transient load and line tests to compare with simulation results.

Load Testing

The setup is the same as the initial startup, except that an additional digital voltmeter is connected between V_{in} and GND, a load is connected between V_{out} and GND and a current meter is connected in series between V_{out} and the load. The load must be able to handle at least rated output power + 50% (7.5 watts for this design). Ideally the load is supplied in the form of a variable load test unit. It can also be done in the form of suitably large power resistors. When using an oscilloscope to measure waveforms on the prototype board, the ground leads of the oscilloscope probes should be as short as possible and the area of the loop formed by the ground lead should be kept to a minimum. This will help reduce ground lead inductance and eliminate EMI noise that is not actually present in the circuit.

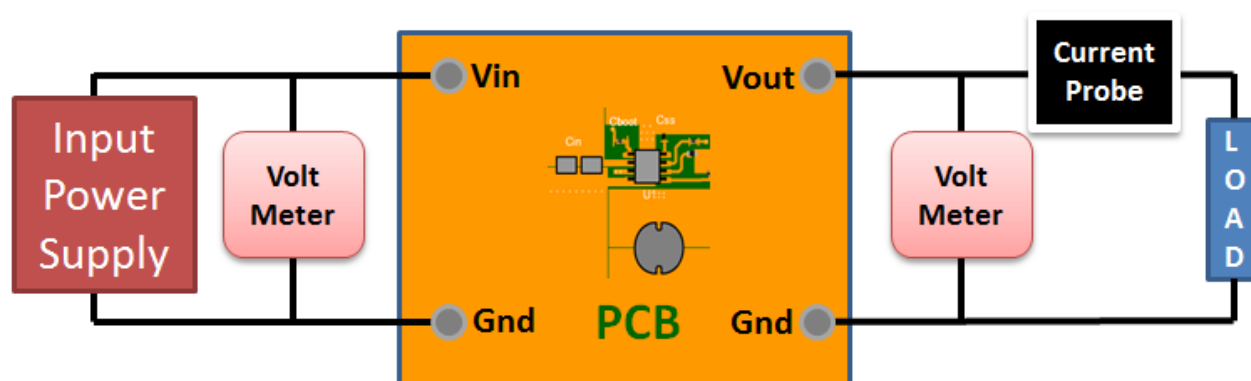

WEBENCH® Electrical Simulation Report

Design Id = 8

sim_id = 1

Simulation Type = Load Transient

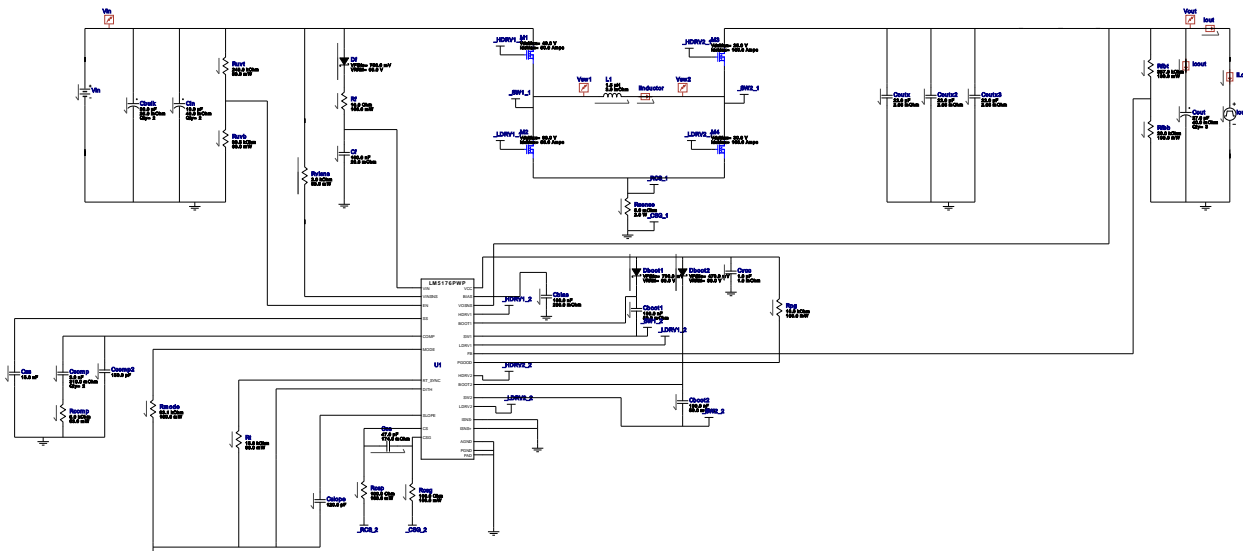

Simulation Parameters

#	Name	Parameter Name	Description	Values
1.	Ccomp2IC		Initial Voltage	1.8577891666666668 V
2.	L1	IC	Initial Current	-10.0 A
3.	Cslope	IC	Initial Voltage	0 V
4.	Cout	IC	Initial Voltage	15.0 V
5.	Iout	signal_type	Signal Type	PULSE
		I1	Initial Load Current	10.0 A
		I2	Minimum Load Current	1.0 A
		Td	Initial Time Delay	8.0912E-5 s
		Tf	Fall Time	100u s
		Tr	Rise Time	100u s
		Pw	Pulse Width	7.503027786008242E-4 s

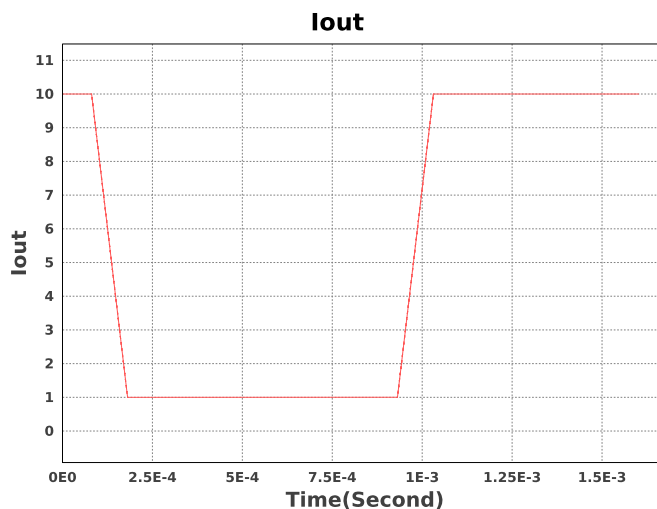
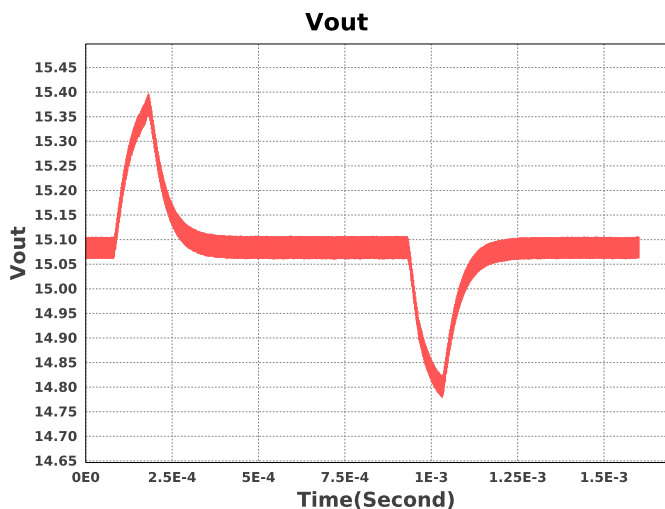

Design Id = 8

sim_id = 2

Simulation Type = Steady State

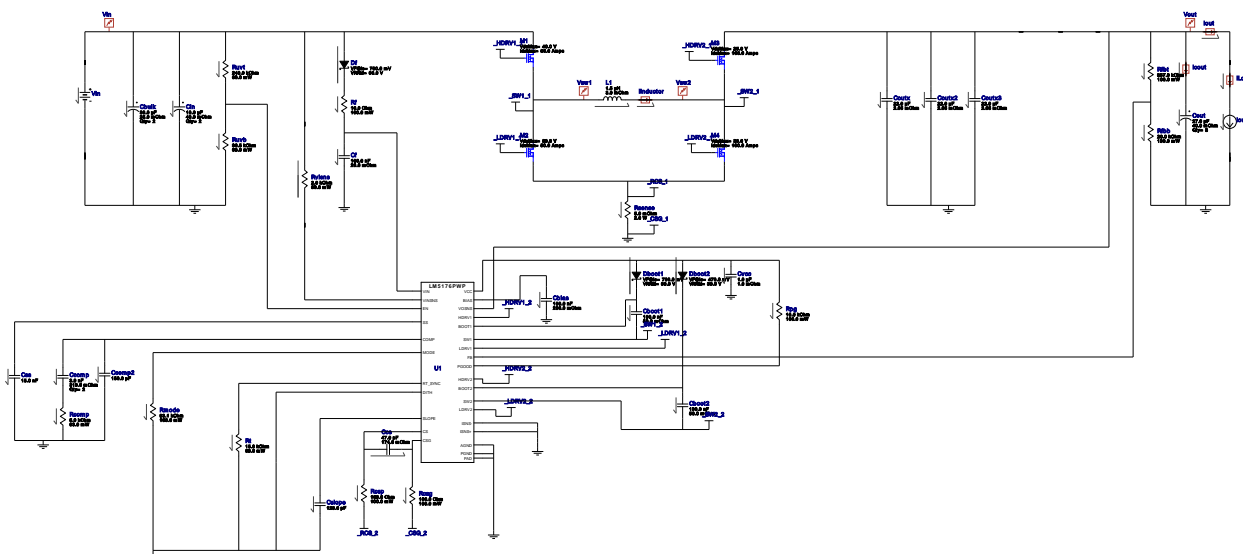

Simulation Parameters

#	Name	Parameter Name	Description	Values
1.	Ccomp2IC		Initial Voltage	1.8577891666666668 V
2.	L1	IC	Initial Current	-10.0 A
3.	Cslope	IC	Initial Voltage	0 V
4.	Cout	IC	Initial Voltage	15.0 V
5.	Iout	I	Load Current	10.0 A

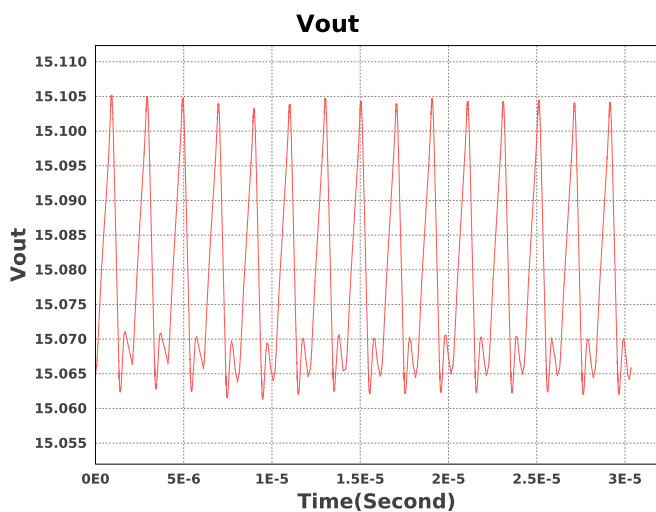

Design Assistance

1. Tip: Snubbers and/or gate resistors may be required to limit the SW1,2 node switching spikes below the IC and FET abs max ratings.
2. Tip: Slope Capacitor: smaller slope capacitors provide better transition region behavior.
3. Master key : 08A2489EE4658D73780B6C9588B88A69[v1]
4. **LM5176** Product Folder : <http://www.ti.com/product/LM5176> : contains the data sheet and other resources.

Important Notice and Disclaimer

TI provides technical and reliability data (including datasheets), design resources (including reference designs), application or other design advice, web tools, safety information, and other resources AS IS and with all faults, and disclaims all warranties. These resources are intended for skilled developers designing with TI products. You are solely responsible for (1) selecting the appropriate TI products for your application, (2) designing, validating and testing your application, and (3) ensuring your application meets applicable standards, and any other safety, security, or other requirements.

These resources are subject to change without notice. TI grants you permission to use these resources only for development of an application that uses the TI products described in the resource. Other reproduction and display of these resources is prohibited. No license is granted to any other TI intellectual property right or to any third party intellectual property right. TI disclaims responsibility for, and you will fully indemnify TI and its representatives against, any claims, damages, costs, losses, and liabilities arising out of your use of these resources.

Providing these resources does not expand or otherwise alter TI's applicable Terms of Sale or other applicable terms available either on ti.com or provided in conjunction with TI products.