

# 24V TO 12V CONVERTER

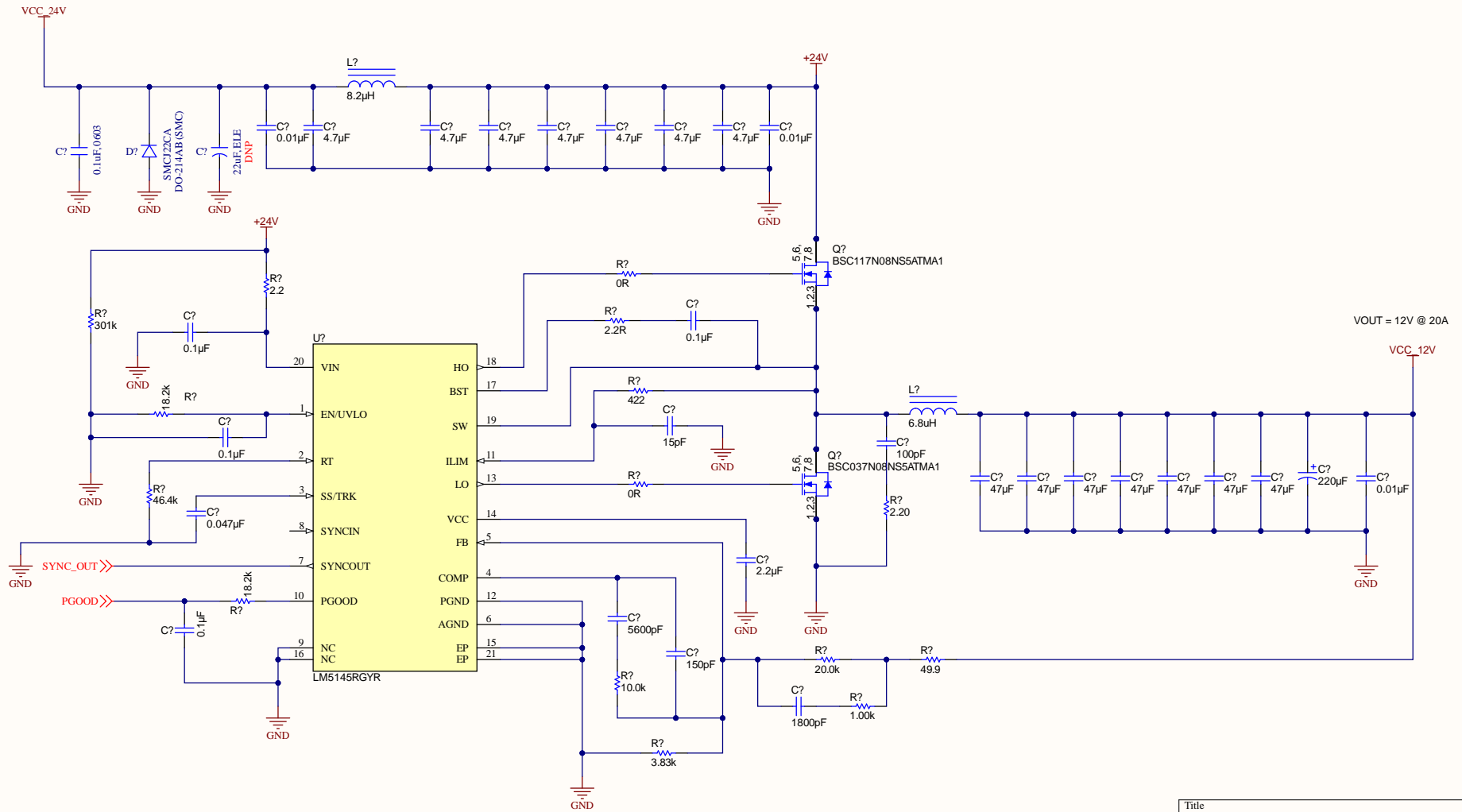

Title		
Size	Number	Revision
B		
Date:	10-22-2024	Sheet of
File:	D:\ABS\...12V conversion.SchDoc	Drawn By:

