

BMS

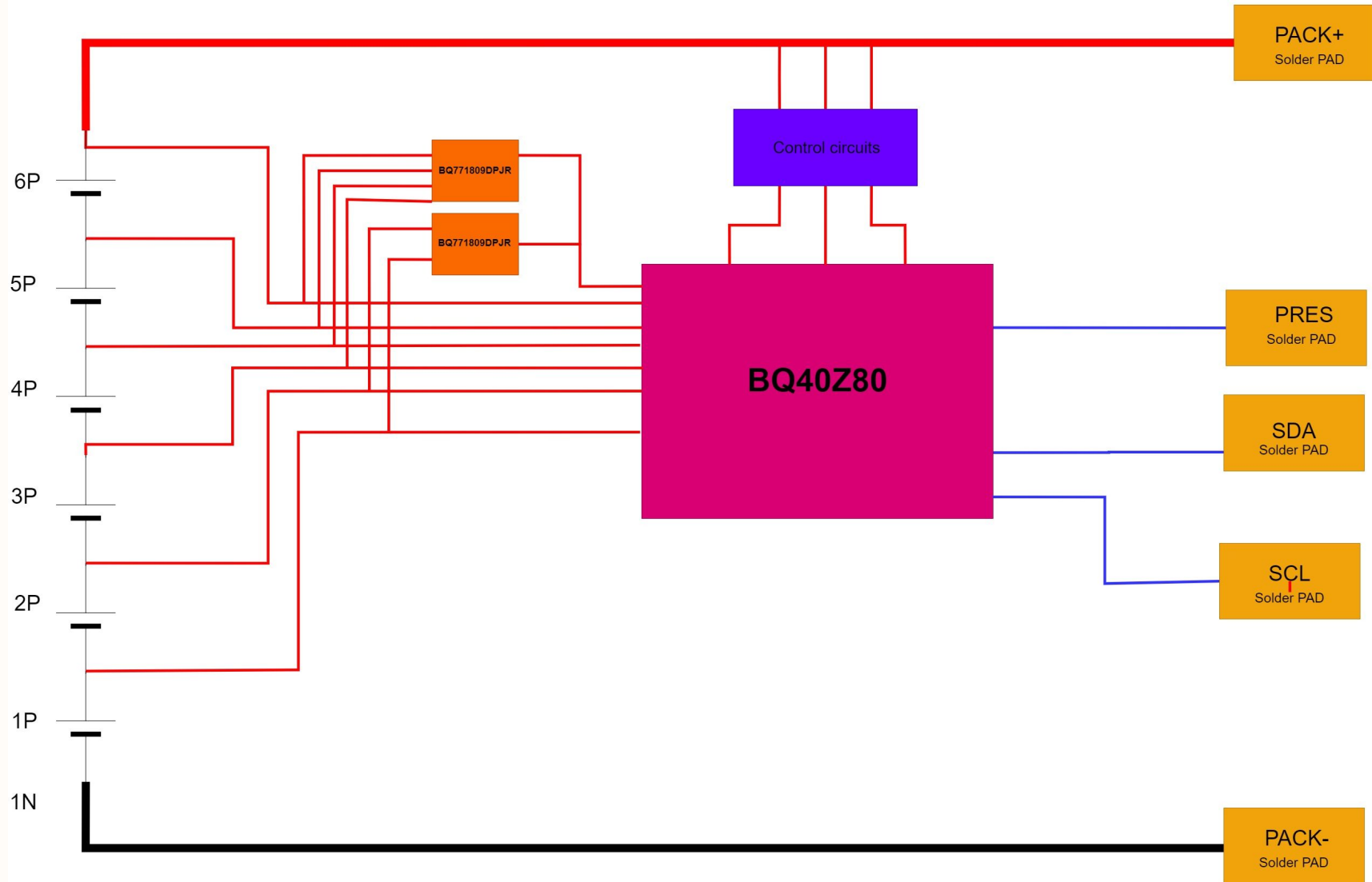

CHAMPIONX <small>PROPRIETARY NOTICE - THE DATA CONTAINED HEREIN IS PROPRIETARY TO CHAMPIONX INCORPORATED AND SHALL NOT BE DUPLICATED, USED, OR DISCLOSED IN WHOLE OR IN PART FOR ANY PURPOSE OTHER THAN FOR WHICH IT WAS FURNISHED WITHOUT THE EXPRESS PERMISSION OF CHAMPIONX INCORPORATED.</small>	PRODUCT FAMILY:	TITLE:	SCALE:
	CODE:	DRAWING NO:	DO NOT SCALE PRINT
	DE3P9	BATTERY BMS BOARD	REV:
		6010200100	0.1
	OWNER:	CHAMPIONX	SHEET SIZE: 0xCAD C
	ENGINEER:	HK	DATE:
			SHEET: 1 OF 3

BMS

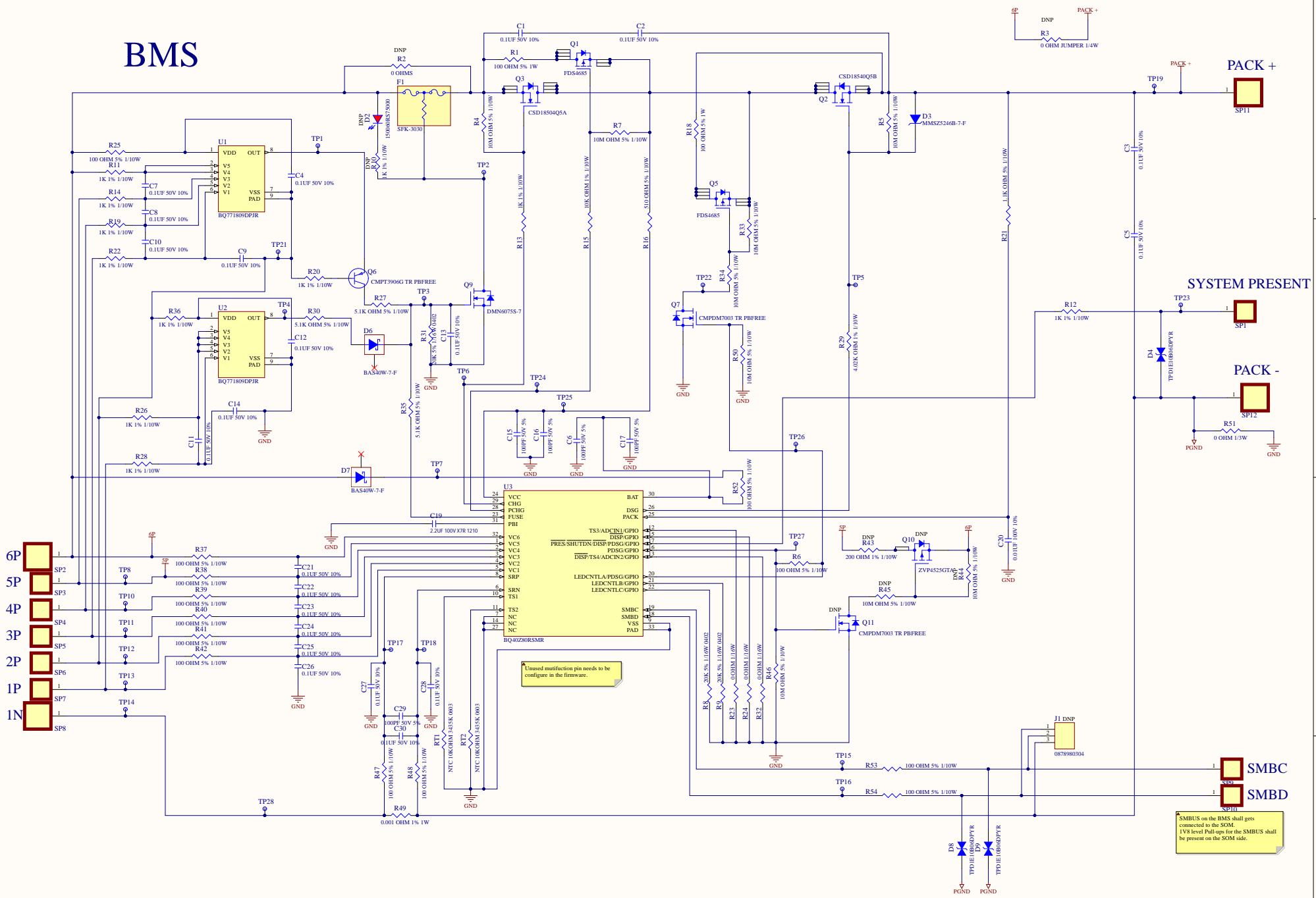

Rev 0.1
First Release

 <small>PROPRIETARY NOTICE - THE DATA CONTAINED HEREIN IS PROPRIETARY TO CHAMPIONX INCORPORATED AND SHALL NOT BE DUPLICATED, USED, OR DISCLOSED IN WHOLE OR IN PART FOR ANY PURPOSE OTHER THAN FOR WHICH IT WAS FURNISHED WITHOUT THE EXPRESS PERMISSION OF CHAMPIONX INCORPORATED.</small>	PRODUCT FAMILY:	TITLE:	SCALE:
	CODE:	DRAWING NO:	REV:
	DE3P9	6010200100	0.1
CHAMPIONX 2445 Technology Forest Blvd. The Woodlands, Texas 77380	OWNER:	ENGINEER:	DATE:
	CHAMPIONX	HK	
			SHEET SIZE: 0xCAD C
			SHEET: 3 OF 3

Comment	Description	Designator	Footprint	LibRef	Quantity
0.1UF 50V 10%	CAP CER 0.1UF 50V X1	C1	CAPC1608X10N		1
0.1UF 50V 10%	CAP CER 0.1UF 50V X1	C2	CAPC1608X10N		1
0.1UF 50V 10%	CAP CER 0.1UF 50V X1	C3	CAPC1608X10N	06035C104K4ZAA	1
0.1UF 50V 10%	CAP CER 0.1UF 50V X1	C4	CAPC1608X10N		1
0.1UF 50V 10%	CAP CER 0.1UF 50V X1	C5	CAPC1608X10N		1
100PF 50V 5%	CAP CER 100PF 50V C1	C6	CAPC1608X10N		1
0.1UF 50V 10%	CAP CER 0.1UF 50V X1	C7	CAPC1608X10N		1
0.1UF 50V 10%	CAP CER 0.1UF 50V X1	C8	CAPC1608X10N		1
0.1UF 50V 10%	CAP CER 0.1UF 50V X1	C9	CAPC1608X10N		1
0.1UF 50V 10%	CAP CER 0.1UF 50V X1	C10	CAPC1608X10N		1
0.1UF 50V 10%	CAP CER 0.1UF 50V X1	C11	CAPC1608X10N		1
0.1UF 50V 10%	CAP CER 0.1UF 50V X1	C12	CAPC1608X10N		1
0.1UF 50V 10%	CAP CER 0.1UF 50V X1	C13	CAPC1608X10N		1
0.1UF 50V 10%	CAP CER 0.1UF 50V X1	C14	CAPC1608X10N		1
100PF 50V 5%	CAP CER 100PF 50V C1	C15	CAPC1608X10N		1
100PF 50V 5%	CAP CER 100PF 50V C1	C16	CAPC1608X10N		1
100PF 50V 5%	CAP CER 100PF 50V C1	C17	CAPC1608X10N		1
2.2UF 100V X7R 1210	CAP CER 2.2UF 100V C19	C19	CAPC3225X30N		1
0.01UF 50V 10%	CAP CER 0.01UF 50V X1	C20	CAPC1608X10N		1
0.1UF 50V 10%	CAP CER 0.1UF 50V X1	C21	CAPC1608X10N		1
0.1UF 50V 10%	CAP CER 0.1UF 50V X1	C22	CAPC1608X10N		1
0.1UF 50V 10%	CAP CER 0.1UF 50V X1	C23	CAPC1608X10N		1
0.1UF 50V 10%	CAP CER 0.1UF 50V X1	C24	CAPC1608X10N		1
0.1UF 50V 10%	CAP CER 0.1UF 50V X1	C25	CAPC1608X10N		1
0.1UF 50V 10%	CAP CER 0.1UF 50V X1	C26	CAPC1608X10N		1
0.1UF 50V 10%	CAP CER 0.1UF 50V X1	C27	CAPC1608X10N		1
0.1UF 50V 10%	CAP CER 0.1UF 50V X1	C28	CAPC1608X10N		1
100PF 50V 5%	CAP CER 100PF 50V C19	C29	CAPC1608X10N		1
0.1UF 50V 10%	CAP CER 0.1UF 50V X1	C30	CAPC1608X10N		1
15000MS75000	LED RED CLEAR 6003	D3	LED-0603		1
MM5252468-7-F	DIODE ZENER 16V 500 D3	SOD-123	MM5252468-7-F		1
TPD1E10806DPYR	TVS DIODE 5.5V5MM 1	D4	2-X150N	TPD1E10806DPYR	1
BA50W-7-F	DIODE SCHOTTKY 40V D6	SOT163P10X200-3N	BA50W-7-F		1
BA50W-7-F	DIODE SCHOTTKY 40V D7	SOT163P10X200-3N	BA50W-7-F		1
TPD1E10806DPYR	TVS DIODE 5.5V5MM 1	D8	2-X150N	TPD1E10806DPYR	1
TPD1E10806DPYR	TVS DIODE 5.5V5MM 1	D9	2-X150N	TPD1E10806DPYR	1
8K-4000	RES 30 0.1% 500 1/4	F1	8K-4000		1
878980304	CONN HEADER SMD 11	MOLEX 878980304	8K-4000	878980304	1
FD5485	MOSFET P-CH 40V 8 A	Q1	SOIC127P600X175-8P	FD5485	1
CS0185405B	MOSFET N-CH 40V 19	Q2	8-Y50N	CS0185405B	1
CS0185405A	MOSFET N-CH 40V 19	Q3	8-Y50N	CS0185405A	1
FD5485	MOSFET P-CH 40V 8 A	Q5	SOIC127P600X175-8P	FD5485	1
CMPT3906G TR PBR	TRANS PNP 40V 0.2A	Q6	SOT-23-3	CMPT3906G TR PBR	1
DMN60755-7	MOSFET N-CH 60V 2A	Q7	SOT-23-3	DMN60755-7	1
DMN60755-7	MOSFET N-CH 60V 2A	Q9	SOT-23-3	DMN60755-7	1
ZPW8252GTA	MOSFET P-CH 250V 2I	Q10	SOT230P700MS0-4N	ZPW8252GTA	1
CMX0001000 TR PBR	MOSFET N-CH 100V 10A	Q11	SOT-23-3	CMX0001000 TR PBR	1
100 OHM 5% 1W	RES-SMD 100 OHM 5% 1	R1	RES06031370N	CR06031370000000	1
0 OHMS	RES-SMD 0 OHM 2W R2	R2	RES06032400N	CR06032400000000	1
0 OHM JUMPER 1/4W	RES 0 OHM JUMPER 1/4	R3	RES06031370N	CR06031370000000	1
10M OHM 5% 1/10W	RES-SMD 10M OHM 5%	R4	RES06031370N	CR06031370000000	1
10M OHM 5% 1/10W	RES-SMD 10M OHM 5%	R5	RES06031370N	CR06031370000000	1
100 OHM 5% 1/10W	RES-SMD 100 OHM 5%	R6	RES06031370N	CR06031370000000	1
10M OHM 5% 1/10W	RES-SMD 10M OHM 5%	R7	RES06031370N	CR06031370000000	1
20K 5% 1/16W 0402	RES-SMD 20K OHM 5%	R8	RES06031370N	CR06031370000000	1
20K 5% 1/16W 0402	RES-SMD 20K OHM 5%	R9	RES06031370N	CR06031370000000	1
1K 1% 1/10W	RES-SMD 1K OHM 1%	R11	RES06031370N	CR06031370000000	1
1K 1% 1/10W	RES-SMD 1K OHM 1%	R12	RES06031370N	CR06031370000000	1
1K 1% 1/10W	RES-SMD 1K OHM 1%	R13	RES06031370N	CR06031370000000	1
1K 1% 1/10W	RES-SMD 1K OHM 1%	R14	RES06031370N	CR06031370000000	1
10K OHM 1% 1/10W	RES-SMD 10K OHM 1%	R15	RES06031370N	CR06031370000000	1
510 OHM 5% 1/10W	RES-SMD 510 OHM 5%	R16	RES06031370N	CR06031370000000	1
100 OHM 5% 1W	RES-SMD 100 OHM 5%	R18	RES06031370N	CR06031370000000	1
1K 1% 1/10W	RES-SMD 1K OHM 1%	R19	RES06031370N	CR06031370000000	1
1K 1% 1/10W	RES-SMD 1K OHM 1%	R20	RES06031370N	CR06031370000000	1
1K 1% OHM 5% 1/10W	RES-SMD 1K OHM 5%	R21	RES06031370N	CR06031370000000	1
1K 1% 1/10W	RES-SMD 1K OHM 1%	R22	RES06031370N	CR06031370000000	1
0 OHM 1/16W	RES-SMD 0 OHM JUM R23	R23	RES06031370N	CR06031370000000	1
0 OHM 1/16W	RES-SMD 0 OHM JUM R24	R24	RES06031370N	CR06031370000000	1
100 OHM 5% 1/10W	RES-SMD 100 OHM 5%	R25	RES06031370N	CR06031370000000	1
1K 1% 1/10W	RES-SMD 1K OHM 1%	R26	RES06031370N	CR06031370000000	1
5.1K OHM 5% 1/10W	RES-SMD 5.1K OHM 5%	R27	RES06031370N	CR06031370000000	1
1K 1% 1/10W	RES-SMD 1K OHM 1%	R28	RES06031370N	CR06031370000000	1
4.02K OHM 1% 1/10W	RES-SMD 4.02K OHM 1%	R29	RES06031370N	CR06031370000000	1
5.1K OHM 5% 1/10W	RES-SMD 5.1K OHM 5%	R30	RES06031370N	CR06031370000000	1
20K 5% 1/16W 0402	RES-SMD 20K OHM 5%	R31	RES06031370N	CR06031370000000	1
0 OHM 1/16W	RES-SMD 0 OHM JUM R32	R32	RES06031370N	CR06031370000000	1
10M OHM 5% 1/10W	RES-SMD 10M OHM 5%	R33	RES06031370N	CR06031370000000	1
10M OHM 5% 1/10W	RES-SMD 10M OHM 5%	R34	RES06031370N	CR06031370000000	1
5.1K OHM 5% 1/10W	RES-SMD 5.1K OHM 5%	R35	RES06031370N	CR06031370000000	1
1K 1% 1/10W	RES-SMD 1K OHM 1%	R36	RES06031370N	CR06031370000000	1
100 OHM 5% 1/10W	RES-SMD 100 OHM 5%	R37	RES06031370N	CR06031370000000	1
100 OHM 5% 1/10W	RES-SMD 100 OHM 5%	R38	RES06031370N	CR06031370000000	1
100 OHM 5% 1/10W	RES-SMD 100 OHM 5%	R39	RES06031370N	CR06031370000000	1
100 OHM 5% 1/10W	RES-SMD 100 OHM 5%	R40	RES06031370N	CR06031370000000	1
100 OHM 5% 1/10W	RES-SMD 100 OHM 5%	R41	RES06031370N	CR06031370000000	1
100 OHM 5% 1/10W	RES-SMD 100 OHM 5%	R42	RES06031370N	CR06031370000000	1
200 OHM 1% 1/10W	RES-SMD 200 OHM 1%	R43	RES06031370N	CR06031370000000	1
10M OHM 5% 1/10W	RES-SMD 10M OHM 5%	R44	RES06031370N	CR06031370000000	1
10M OHM 5% 1/10W	RES-SMD 10M OHM 5%	R45	RES06031370N	CR06031370000000	1
10M OHM 5% 1/10W	RES-SMD 10M OHM 5%	R46	RES06031370N	CR06031370000000	1
100 OHM 5% 1/10W	RES-SMD 100 OHM 5%	R47	RES06031370N	CR06031370000000	1
100 OHM 5% 1/10W	RES-SMD 100 OHM 5%	R48	RES06031370N	CR06031370000000	1
0.001 OHM 1% 1W	RES 0.001 OHM 1% 1	R49	RES06031370N	CR06031370000000	1
10M OHM 5% 1/10W	RES-SMD 10M OHM 5%	R50	RES06031370N	CR06031370000000	1
0 OHM 1/16W	RES-SMD 0 OHM JUM R51	R51	RES06031370N	CR06031370000000	1
100 OHM 5% 1/10W	RES-SMD 100 OHM 5%	R52	RES06031370N	CR06031370000000	1
100 OHM 5% 1/10W	RES-SMD 100 OHM 5%	R53	RES06031370N	CR06031370000000	1
100 OHM 5% 1/10W	RES-SMD 100 OHM 5%	R54	RES06031370N	CR06031370000000	1
NTC 10KOHM 3435K	THERMISTOR NTC 10K	RT1	THERM NTC1608X1	NTC10K03E13103E1T	1
NTC 10KOHM 3435K	THERMISTOR NTC 10K	RT2	THERM NTC1608X1	NTC10K03E13103E1T	1
Solder PAD	Solder Pad	SP1	SMD SQUARE PADS	Solder PAD	1
Large solder PAD	Large solder Pad	SP2	SMD SQUARE PADS	Large solder PAD	1
Solder PAD	Solder Pad	SP3	SMD SQUARE PADS	Solder PAD	1
Solder PAD	Solder Pad	SP4	SMD SQUARE PADS	Solder PAD	1
Solder PAD	Solder Pad	SP5	SMD SQUARE PADS	Solder PAD	1
Solder PAD	Solder Pad	SP6	SMD SQUARE PADS	Solder PAD	1
Solder PAD	Solder Pad	SP7	SMD SQUARE PADS	Solder PAD	1
Large solder PAD	Large solder Pad	SP8	SMD SQUARE PADS	Large solder PAD	1
Solder PAD	Solder Pad	SP9	SMD SQUARE PADS	Solder PAD	1
Solder PAD	Solder Pad	SP10	SMD SQUARE PADS	Solder PAD	1
Large solder PAD	Large solder Pad	SP11	SMD SQUARE PADS	Large solder PAD	1
Large solder PAD	Large solder Pad	SP12	SMD SQUARE PADS	Large solder PAD	1
BO771809DPR	IC BATT PROT LI-ION	L1	8-WS0N-4X3	BO771809DPR	1
BO771809DPR	IC BATT PROT LI-ION	L2	8-WS0N-4X3	BO771809DPR	1
BO40200804R	IC BATT MNUC LI-ION	L3	WQFN-32	BO40200804R	1