

RC Snubber Design in Synchronous Buck Converter

In high frequency synchronous buck converters, excessive switching spikes and ringing can develop across the Mosfets during the switching interval, which is caused from the non-ideal characteristic of the switches, as well as parasitic components from the layout. Figure 1 shows a typical switching waveform in a synchronous buck converter. The ringing causes fare amount of switching loss and EMI noise, which may affect the normal operation of the IC sometime. In addition, extra voltage stress from the ringing calls for higher voltage rating Mosfet, which results in higher conduction loss due to higher on-resistance at higher voltage rating.

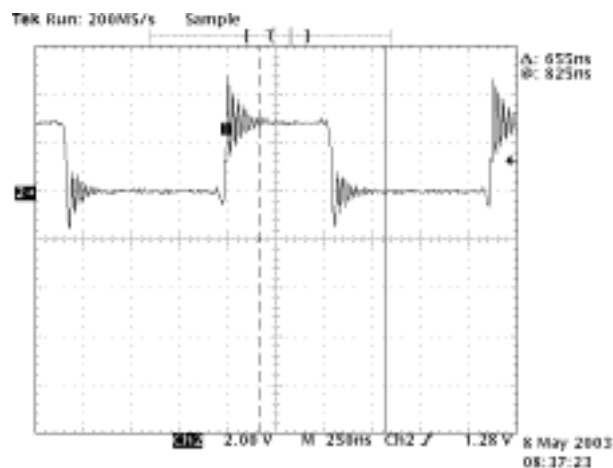

Fig.1 Typical switching waveform across the Mosfet

One way to eliminate the ring and reduce the spike is to add a RC damping circuit cross the switch, shown in Fig. 2. The RC network is probably the most widely used snubber circuit. It's simple and cheap. It provides damping, as well as the control to the rate of voltage rise.

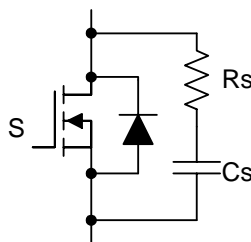

Fig.2 RC snubber across the switch

Choose the values of RC snubber

The snubber capacitance must be larger than the resonant circuit capacitance but must be small enough to keep the power dissipation on the resistor minimum. The parasitic capacitance C_p is mainly from the output capacitance of the switch, which can be found from the datasheet. The R-value should be close to the impedance of the parasitic resonance, which it is intended to damp. A better way to design the RC snubber is to leave the placeholder in the PCB board and then choose the RC value by experiment after the board is built up and running, which will be discussed in the following section.

First power up the board and observe the switch voltage waveform without the capacitor in the circuit. Write down the oscillation period t_1 . Then add a capacitor C_s (Resistor R_s is shorted for now) in the circuit in the snubber position, shown in Fig.2. Start with a small value of the capacitor and increase the value of the capacitor till the period (t_2) of the ringing to be damped has been doubled. This is near optimum value for capacitor since it allows damping very near $Q=1$. The resonant period can be calculated by Eq.1.

$$t_1 = 2 \cdot \pi \cdot \sqrt{L_p \cdot C_p}, \text{ Eq.1a}$$

$$t_2 = 2 \cdot \pi \cdot \sqrt{L_p \cdot (C_p + C_s)}, \text{ Eq.1b}$$

Since $t_2 = 2 \cdot t_1$, then the circuit capacitance is four times of the original value, that is:

$$C_p + C_s = 4 \cdot C_p$$

So the circuit parasitic capacitance C_p is one third of the added additional capacitance C_s , that is:

$$C_p = \frac{C_s}{3} \text{ Eq.2}$$

After C_p is determined, the circuit inductance, L_p , can be calculated from Eq.1.

The characteristic impedance of the parasitic resonant circuit is calculated by Eq.3.

$$Z_o = \sqrt{\frac{L_p}{C_p}} \text{ Eq.3}$$

Pick the value of the snubber resistor equal to Z_o , that is $R_s = Z_o$, which provides near $Q=1$ damping. Add the RC with calculated value in the circuit to form a snubber. The RC network may be needed for each switch.

Design Example

Taking the waveform in Fig. 1, the switch frequency is 700KHz. The input voltage is 2.5V and output is 1.2V/10A. The oscillation period of the ring without RC snubber is 24.8ns. By adding a 5600pF capacitor, the oscillation period increase to 50ns. From Eq.2, get $C_p = 1900pF$. From Eq.1, L_p is calculated as 7.8nH. The impedance of the resonance from Eq.3 is 2.0Ω. So a 2.0Ω resistor is added to the circuit in series with C_s to form the RC network. Fig. 3 shows the synchronous buck converter with RC snubber network across both switches. With the RC values calculated from above, the voltage waveform is shown in Fig.4.

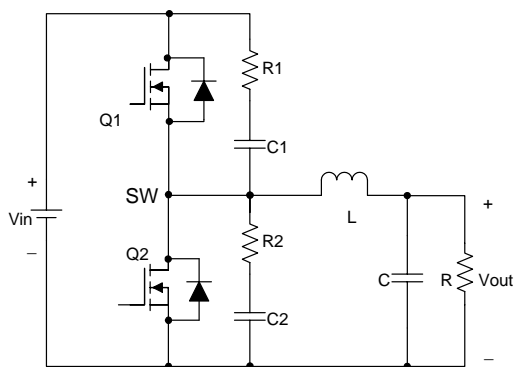

Fig.3 Synchronous buck with RC snubber

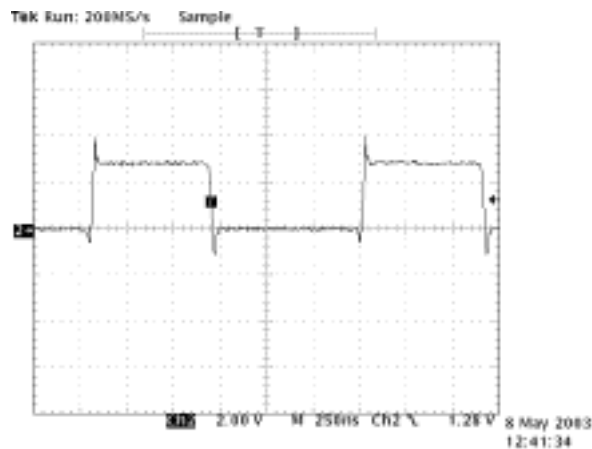

Fig.4 Switching node waveform with RC snubber across both switches

Power Dissipation of RC Snubber

The power dissipation of the resistor can be estimated by assuming the time constant of RC snubber is short compared to the switching period but is long compared to the voltage rise time. During every switching interval, the capacitor C_s is charged from 0V to V_{DS} or discharged from V_{DS} to 0V through the resistor. From [1], the power dissipation is independent of the resistor and can be estimated by Eq.4.

$$P = 2 \cdot \left(\frac{1}{2} \cdot C_s \cdot V_{DS}^2 \right) \cdot f, \text{ Eq. 4}$$

In which, P is the power dissipation of the snubber resistor; V_{DS} is the maximum voltage across the switch; C_s is the snubber capacitor; f is the switching frequency.

The power loss in the design example mentioned above is about 32.8mW, which is about 2.7% of the total output power. So a 2.0Ω resistor with 0603 package (0.1 watts power dissipation @ 70°C) can be used.

From the above analysis, C_s is three times of the output capacitance of the switch, which can be found in the datasheet. So the wattage of the resistor can be estimated during schematic design, which makes it possible to leave suitable package size placeholder on the PCB to avoid flame and unnecessary redesign.

Summary

This application note discusses an experimental way to design RC snubber network in synchronous buck converter. The power dissipation of the snubber resistor is estimated for choosing the suitable package size of the resistor.

Reference:

- [1] Philip C.Todd, “Snubber Circuits: Theory, Design and Application”, May 93, Unitrode Power Supply Seminar, SEM-900.
- [2] Laszlo Balogh, “Implementing Multi-State Charge Algorithm with UC3909 Switch mode Lead-Acid Battery Charger Controller”, Unitrode Application note, Literature number U-155.