

TABLE OF CONTENTS

PAGE	DESCRIPTION
1	Contents, Revision History, Design Notes
2	Power Supply
3	

DESIGN NOTES:

1. All resistors are +/-1% tolerance unless otherwise indicated.

LAYOUT NOTES:

REVISION HISTORY

REV	DATE	PAGES	DESCRIPTION
1	2023-09-20	All	First release.
2			

Title		
150 VDC isolated power supply		
Size A	Document Number 800-00157	Rev 1
Date:	Sunday, September 24, 2023	Sheet 1 of 2

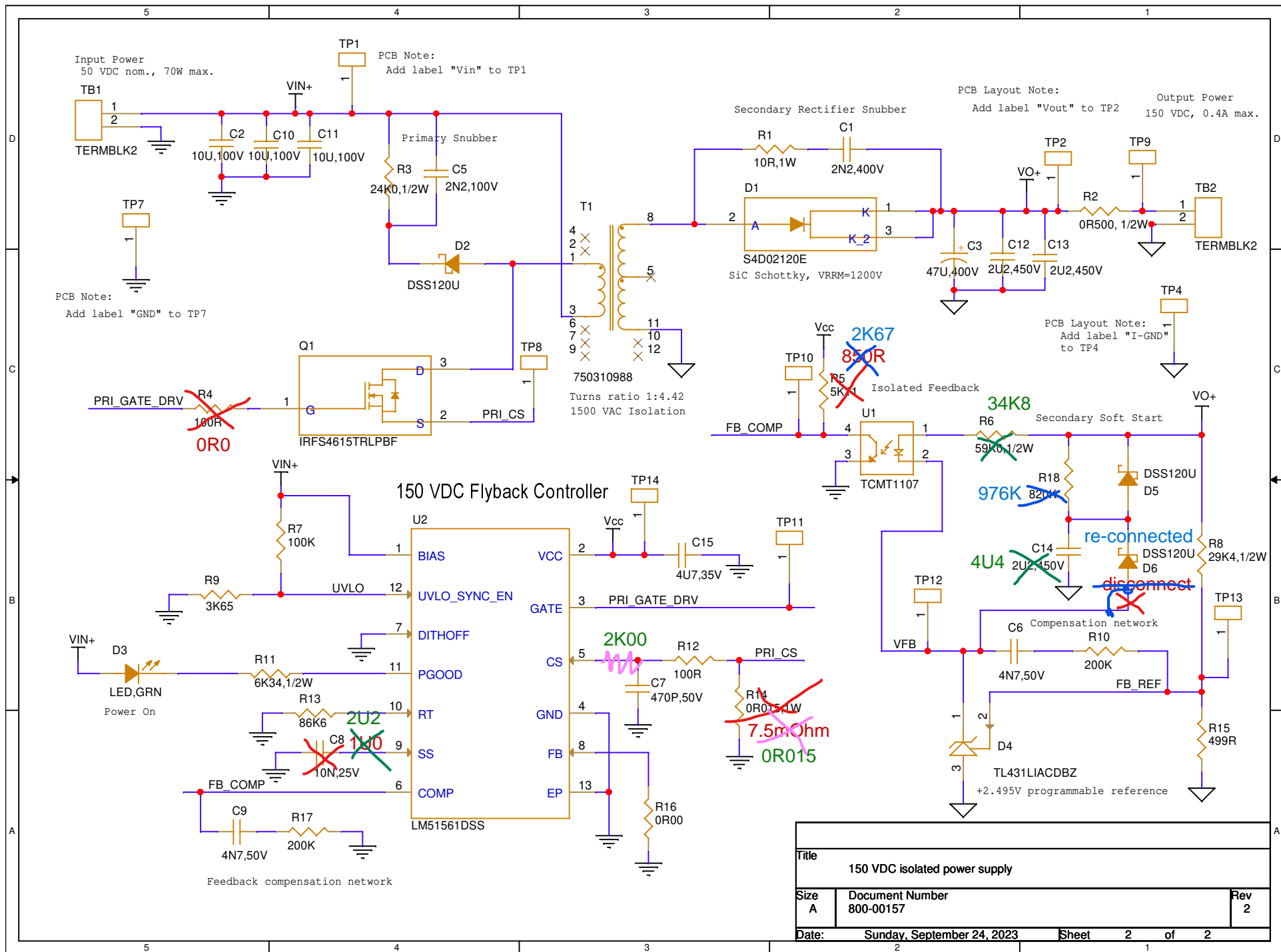

Title		
150 VDC isolated power supply		
Size A	Document Number 800-00157	Rev 2
Date:	Sunday, September 24, 2023	Sheet 2 of 2