

24V (220W) DC-DC converter

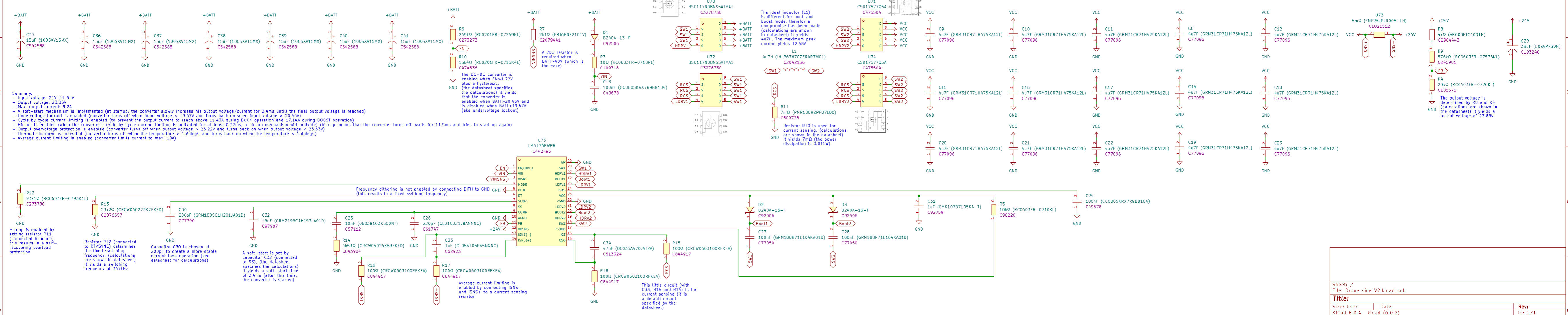

Sheet: /		
File: Drone side V2.kicad_sch		
Title:		
Size: User	Date:	Rev:
KiCad E.D.A.	kicad (6.0.2)	Id: 1/1