

# INTERFACE - USB3.1

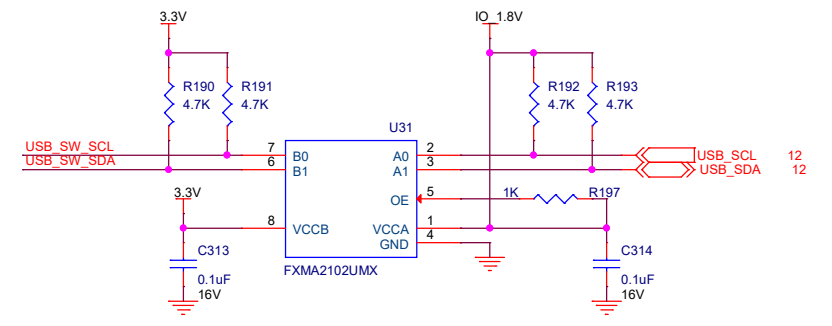

Intel Corporation, 301, Bibo Rd #888, Shanghai, China, 201203 Copyright (c) 2017, Intel Corporation. All Rights Reserved.		
Title <b>Cyclone® 10 GX Development Kit Board</b>		
Size <b>B</b>	Document Number <b>6XX-44528R</b>	Rev <b>A1</b>
Date: <b>Tuesday, November 14, 2017</b>	Sheet <b>24</b>	of <b>43</b>

# INTERFACE - USB2.0

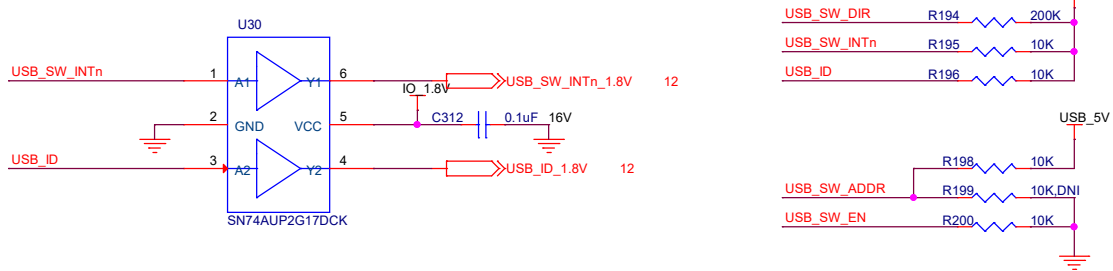
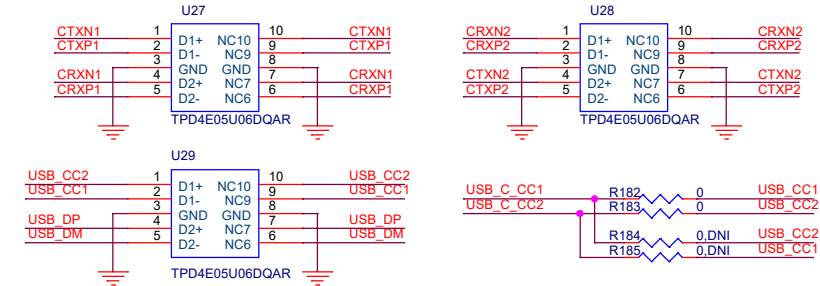
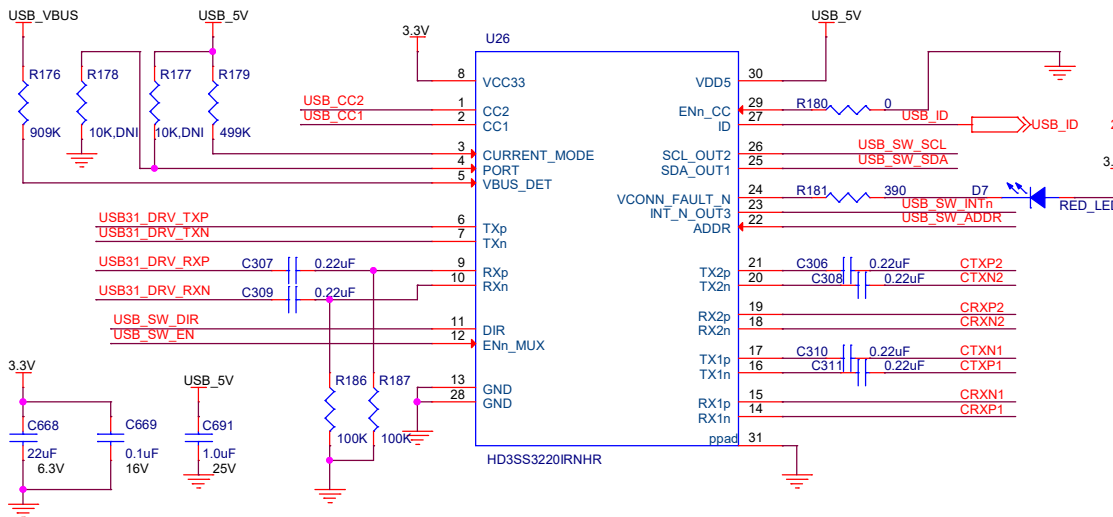
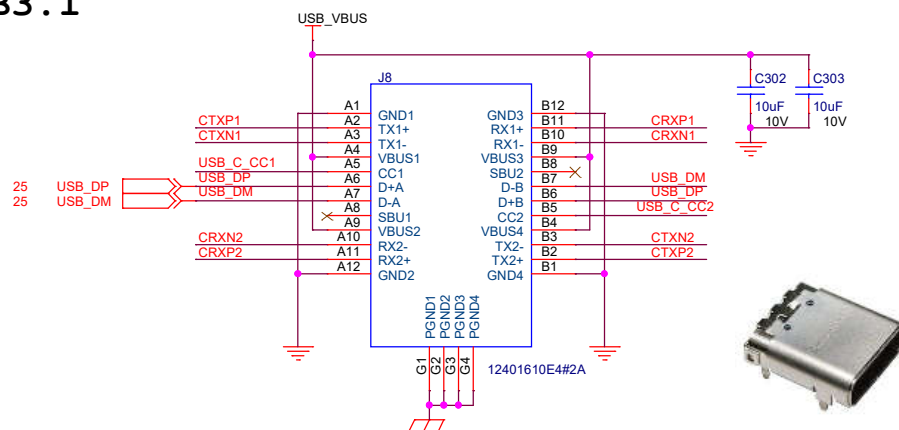
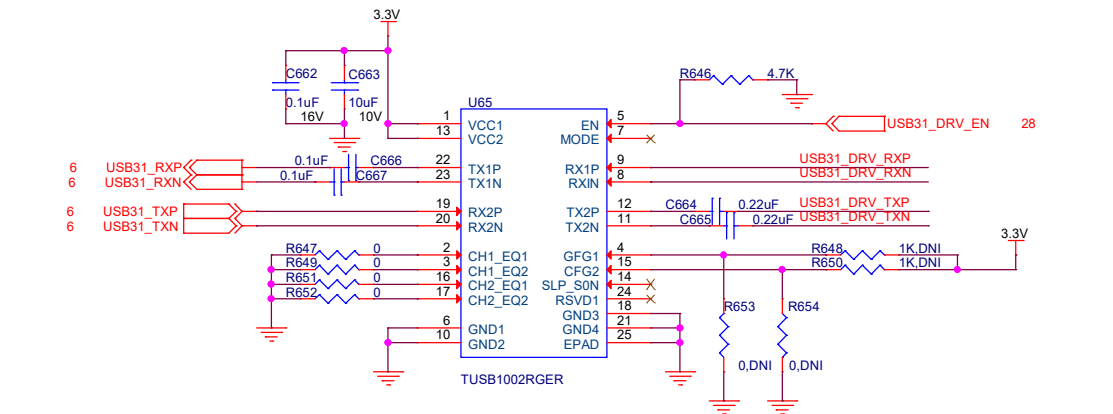
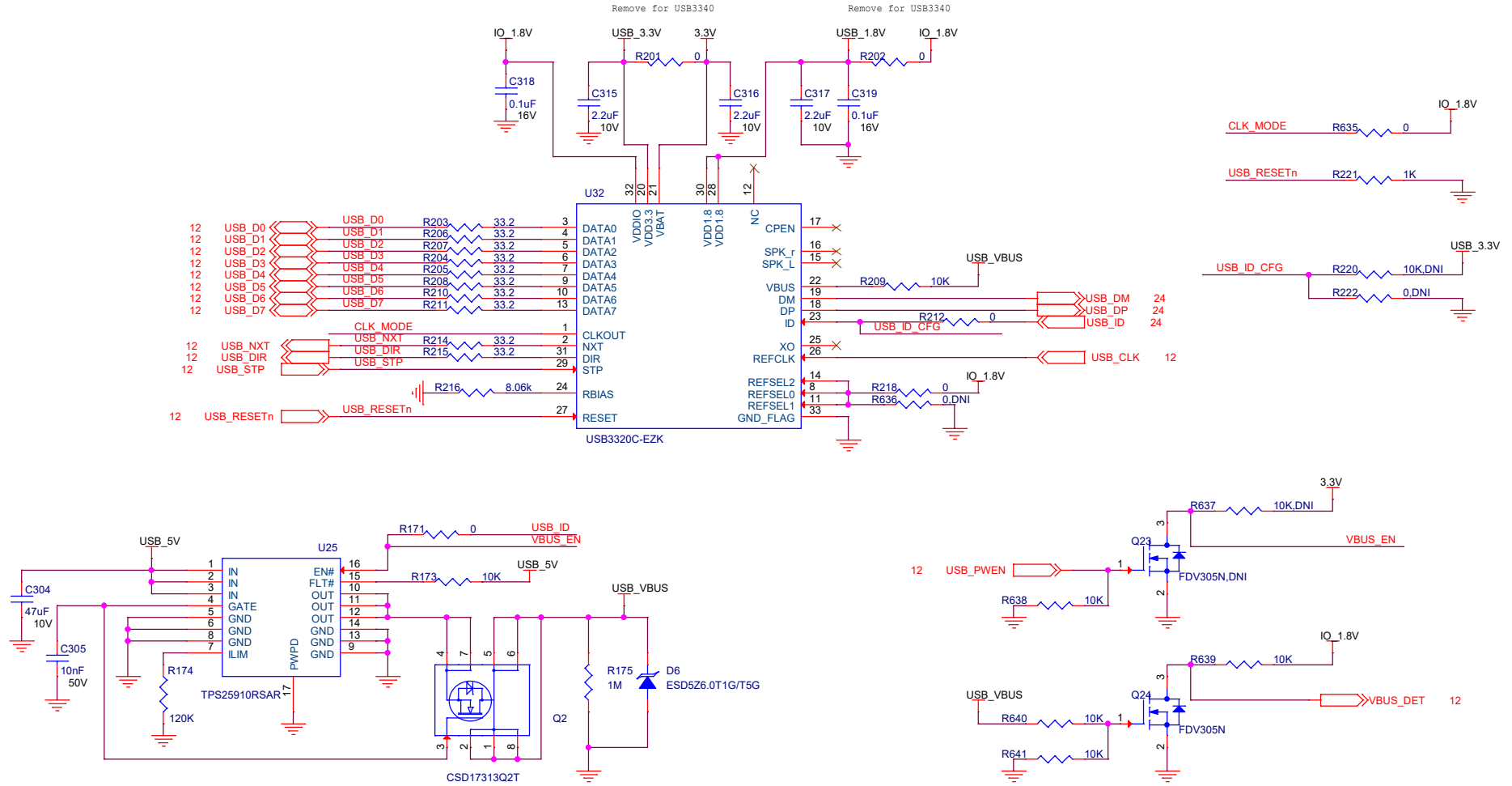

Intel Corporation, 301, Bibo Rd #888, Shanghai, China, 201203  
Copyright (c) 2017, Intel Corporation. All Rights Reserved.

Title Cyclone® 10 GX Development Kit Board

Size B	Document Number 6XX-44528R	Rev A1
--------	----------------------------	--------

Date: Tuesday, November 14, 2017 Sheet 25 of 43