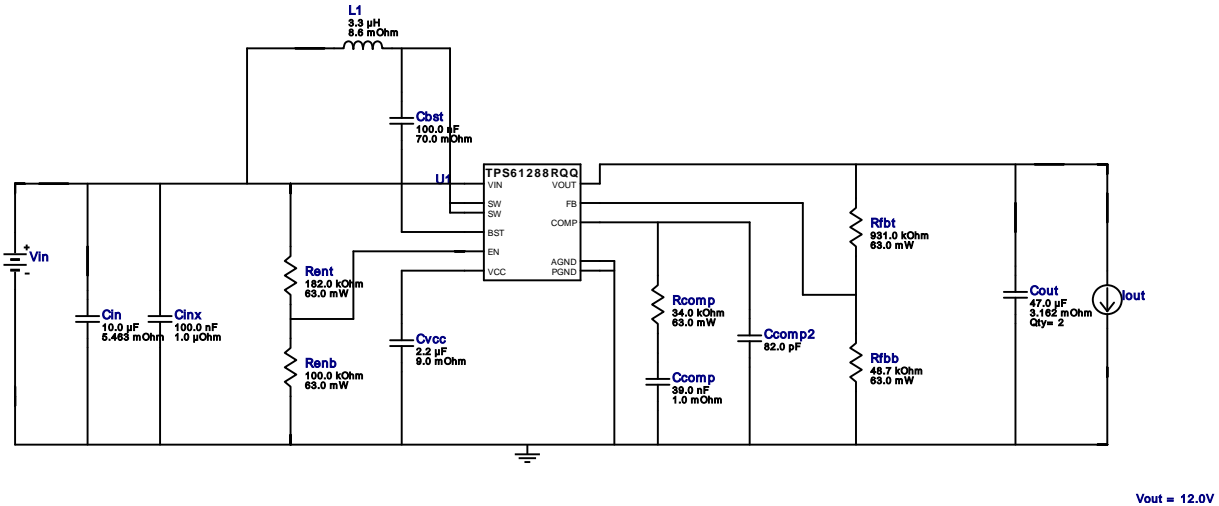
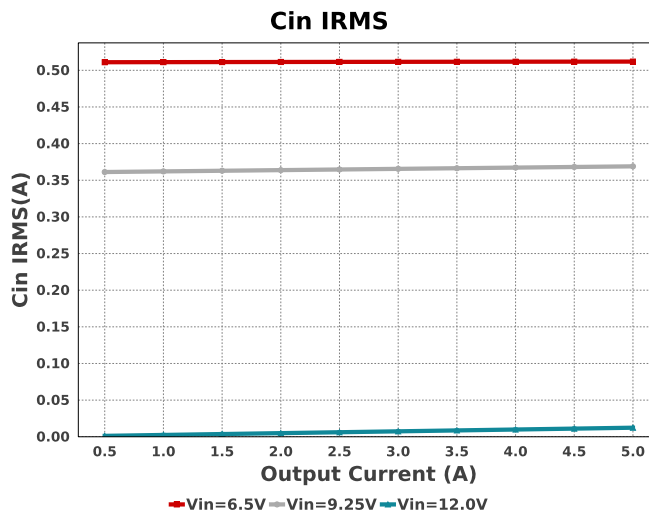
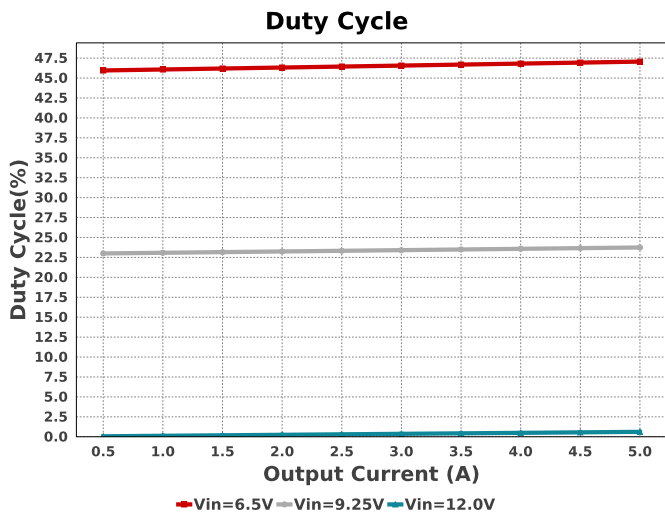
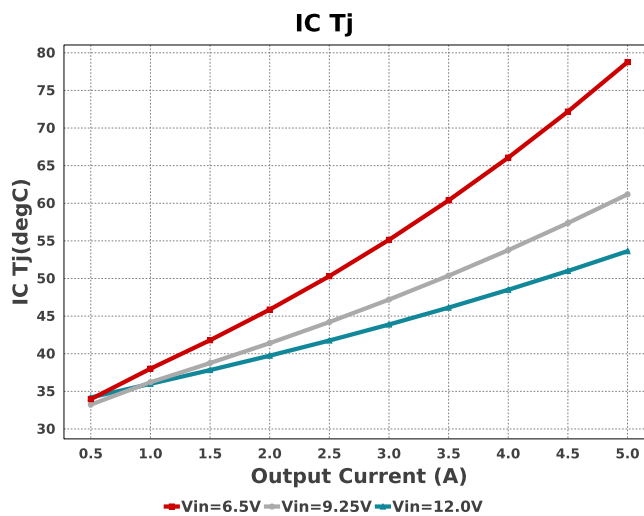
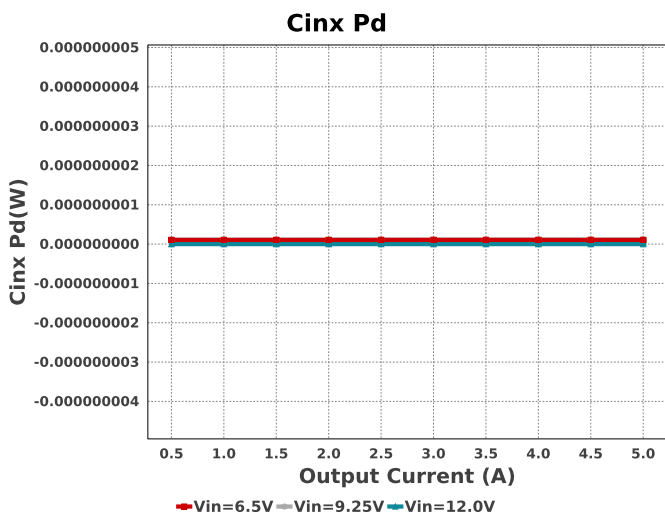

**WEBENCH® Design Report**

 Design : 11 TPS61288RQQR  
 TPS61288RQQR 6.5V-12V to 12.00V @ 5A

**Electrical BOM**

Name	Manufacturer	Part Number	Properties	Qty	Price	Footprint
Cbst	TDK	C0603X5R1A104K030BC Series= X5R	Cap= 100.0 nF ESR= 70.0 mOhm VDC= 10.0 V IRMS= 0.0 A	1	\$0.01	0201 2 mm <sup>2</sup>
Ccomp	MuRata	GRM033R60J393KE19D Series= X5R	Cap= 39.0 nF ESR= 1.0 mOhm VDC= 6.3 V IRMS= 0.0 A	1	\$0.01	0201 2 mm <sup>2</sup>
Ccomp2	Yageo	CC0805JRNPO9BN820 Series= C0G/NP0	Cap= 82.0 pF VDC= 50.0 V IRMS= 0.0 A	1	\$0.01	0805 7 mm <sup>2</sup>
Cin	Taiyo Yuden	MSAST21GBB5106MTNA01 Series= X5R	Cap= 10.0 uF ESR= 5.463 mOhm VDC= 25.0 V IRMS= 2.36768 A	1	\$0.04	0805 7 mm <sup>2</sup>
Cinx	CUSTOM	CUSTOM Series= ?	Cap= 100.0 nF ESR= 1.0 uOhm VDC= 18.0 V IRMS= 13.4314 mA	1	NA	CUSTOM 0 mm <sup>2</sup>
Cout	TDK	CGA9N3X7R1C476M230KB Series= X7R	Cap= 47.0 uF ESR= 3.162 mOhm VDC= 16.0 V IRMS= 5.1344 A	2	\$0.67	2220_250 54 mm <sup>2</sup>
Cvcc	MuRata	GRM188R71A225KE15D Series= X7R	Cap= 2.2 uF ESR= 9.0 mOhm VDC= 10.0 V IRMS= 3.3 A	1	\$0.02	0603 5 mm <sup>2</sup>
L1	Coilcraft	XAL7070-332MEB	L= 3.3 uH 8.6 mOhm	1	\$1.19	XAL7070 87 mm <sup>2</sup>
Rcomp	Vishay-Dale	CRCW040234K0FKED Series= CRCW..e3	Res= 34.0 kOhm Power= 63.0 mW Tolerance= 1.0%	1	\$0.01	0402 3 mm <sup>2</sup>

Name	Manufacturer	Part Number	Properties	Qty	Price	Footprint
Renb	Vishay-Dale	CRCW0402100KFKED Series= CRCW..e3	Res= 100.0 kOhm Power= 63.0 mW Tolerance= 1.0%	1	\$0.01	0402 3 mm <sup>2</sup>
Rent	Vishay-Dale	CRCW0402182KFKED Series= CRCW..e3	Res= 182.0 kOhm Power= 63.0 mW Tolerance= 1.0%	1	\$0.01	0402 3 mm <sup>2</sup>
Rfbb	Vishay-Dale	CRCW040248K7FKED Series= CRCW..e3	Res= 48.7 kOhm Power= 63.0 mW Tolerance= 1.0%	1	\$0.01	0402 3 mm <sup>2</sup>
Rfbt	Vishay-Dale	CRCW0402931KFKED Series= CRCW..e3	Res= 931.0 kOhm Power= 63.0 mW Tolerance= 1.0%	1	\$0.01	0402 3 mm <sup>2</sup>
U1	Texas Instruments	TPS61288RQQR	Switcher	1	\$2.73	RQQ0011A-MFG 9 mm <sup>2</sup>

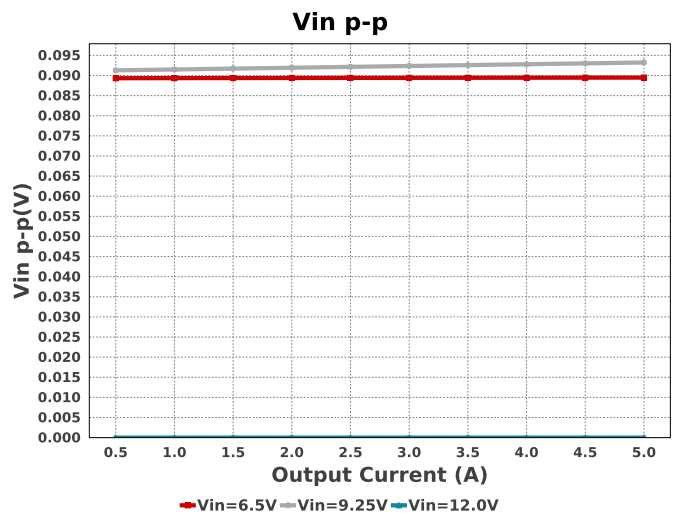
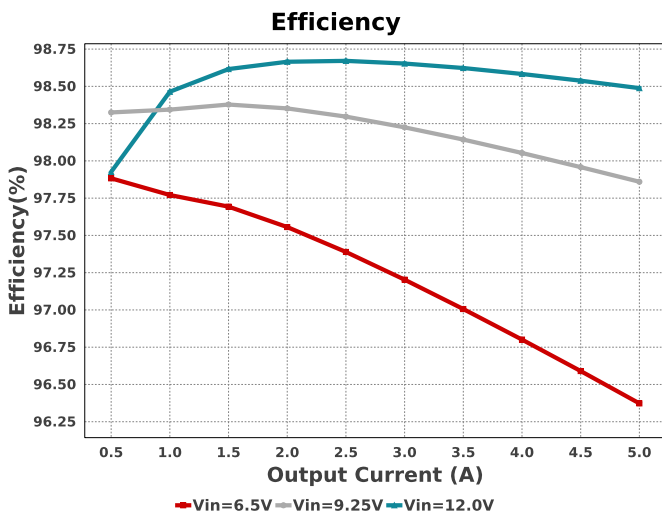
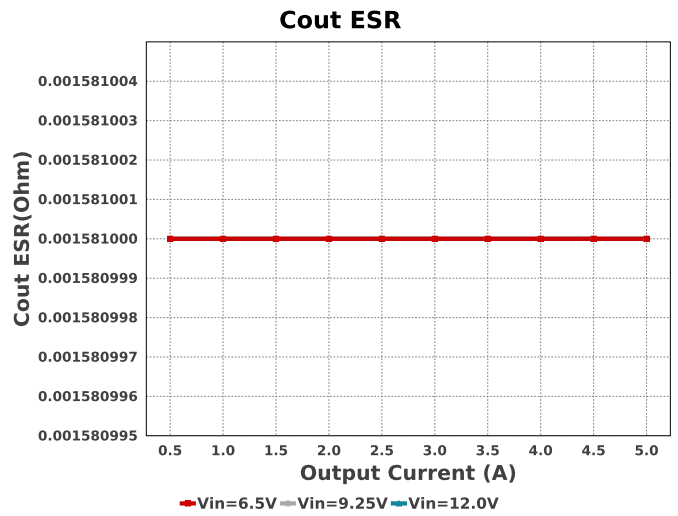
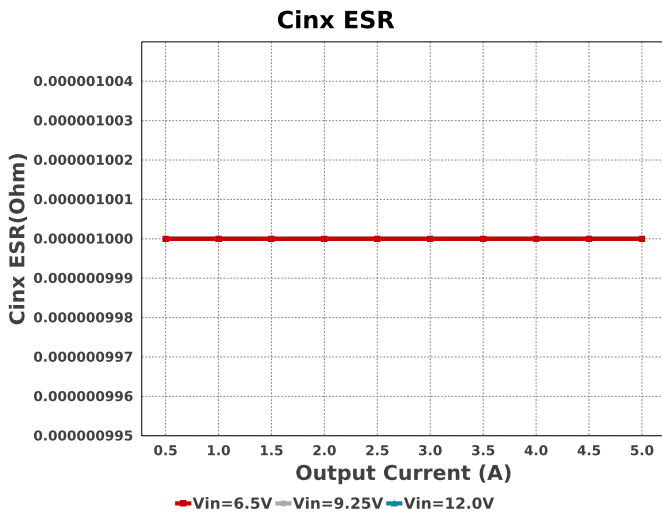
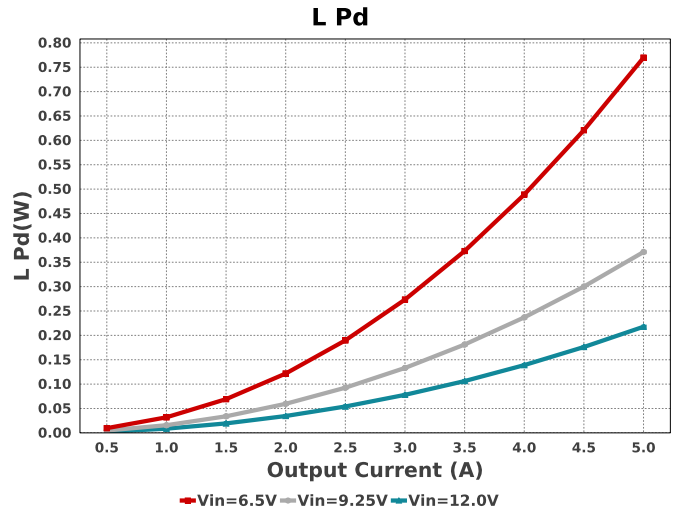
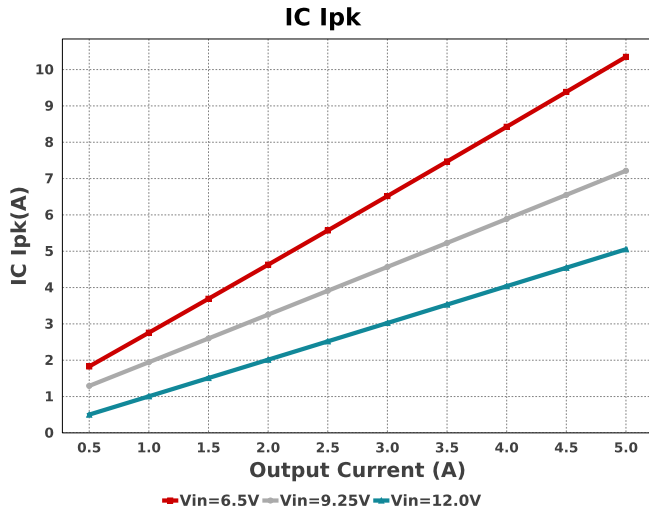

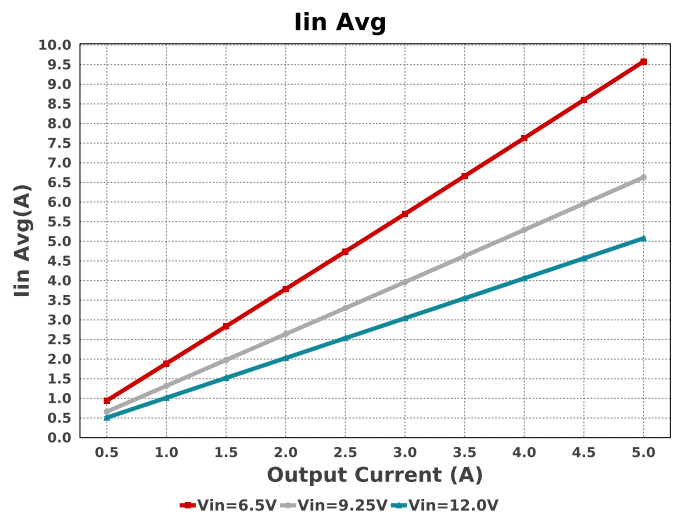
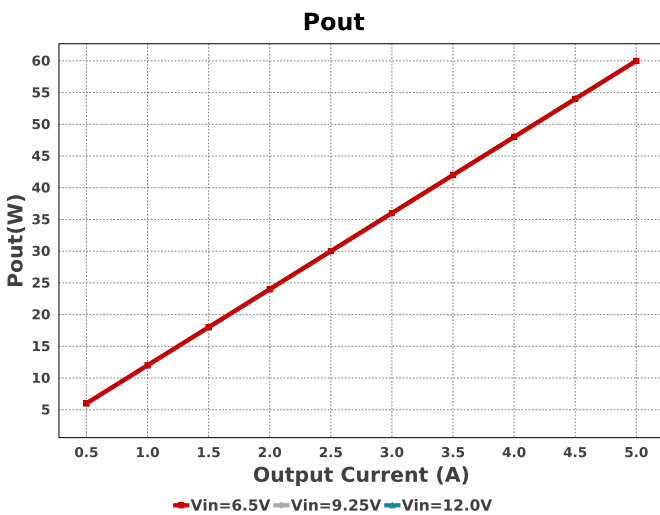
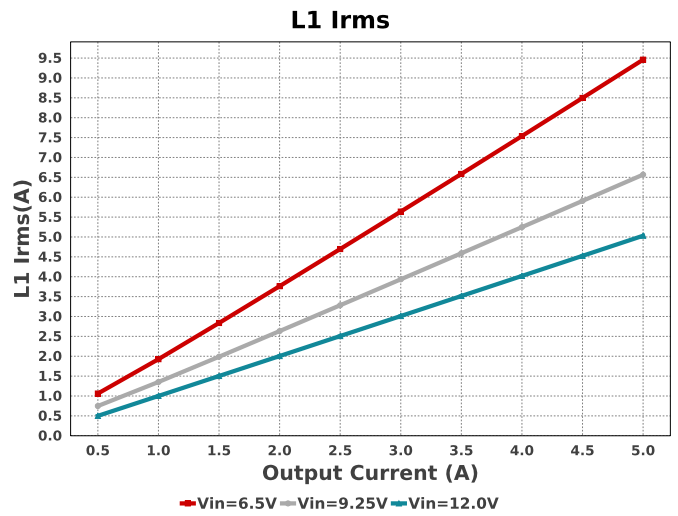
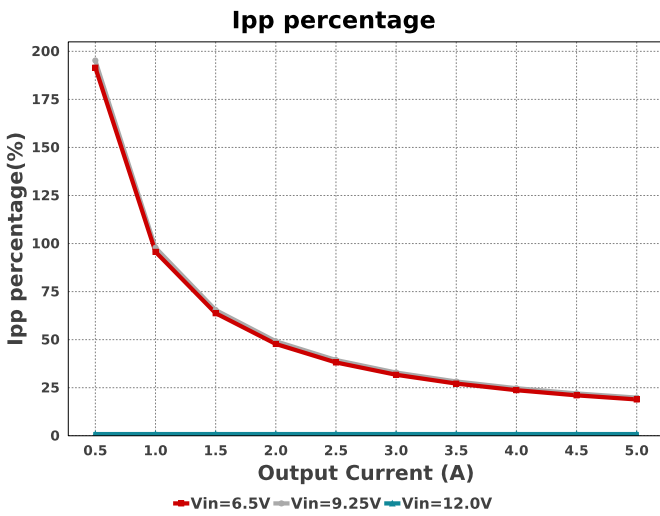
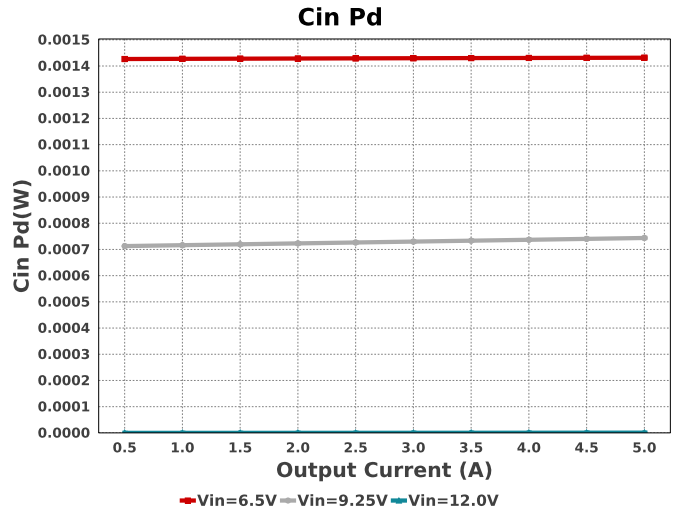
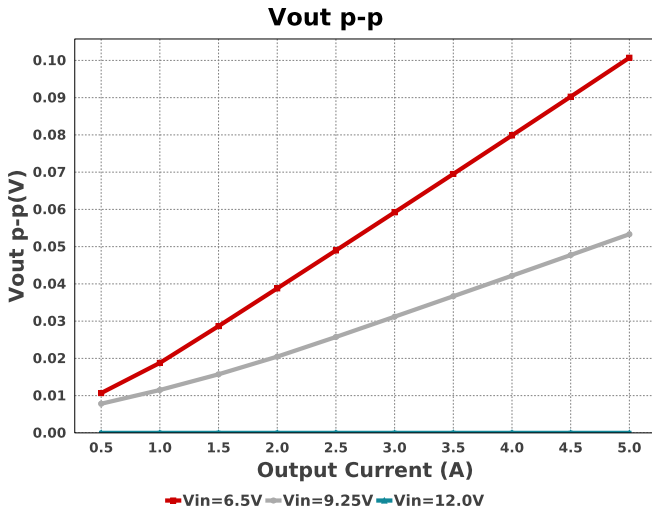



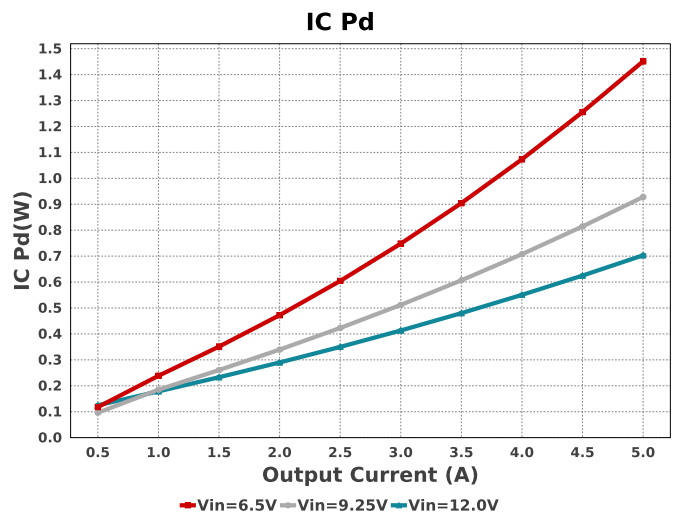
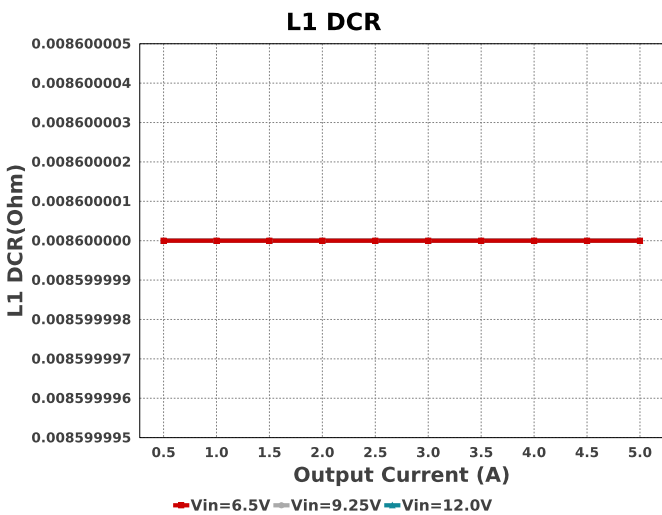
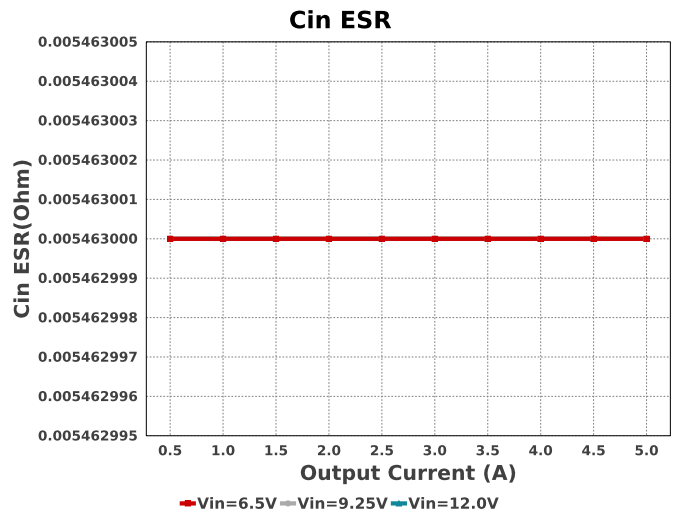
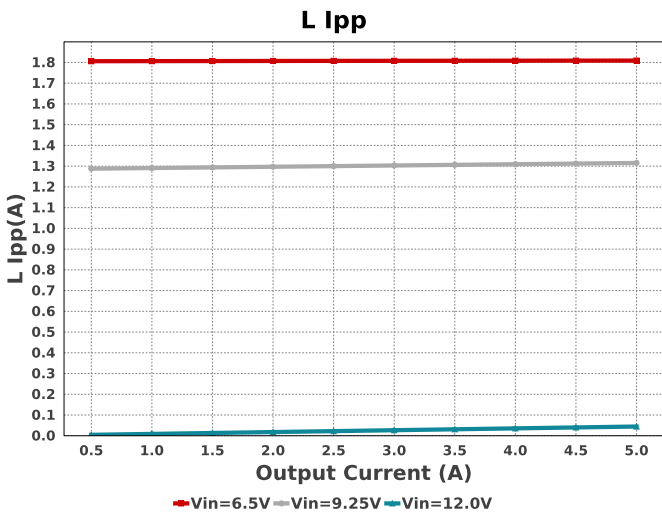
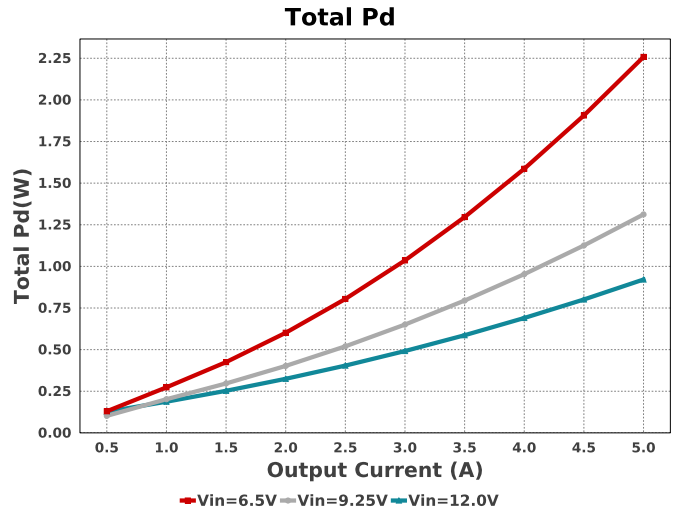
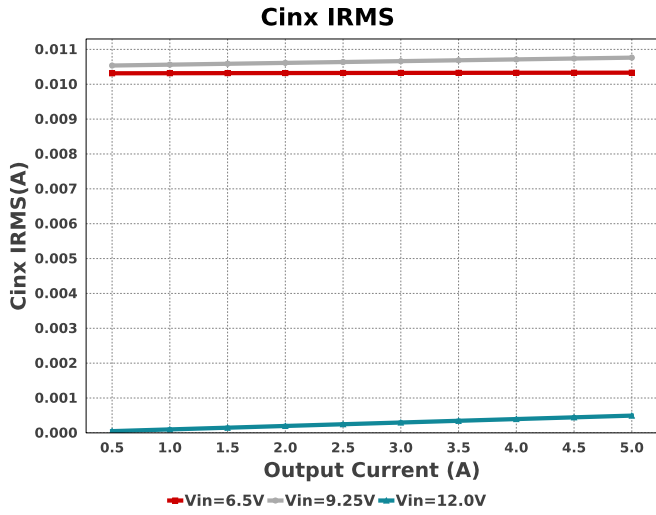

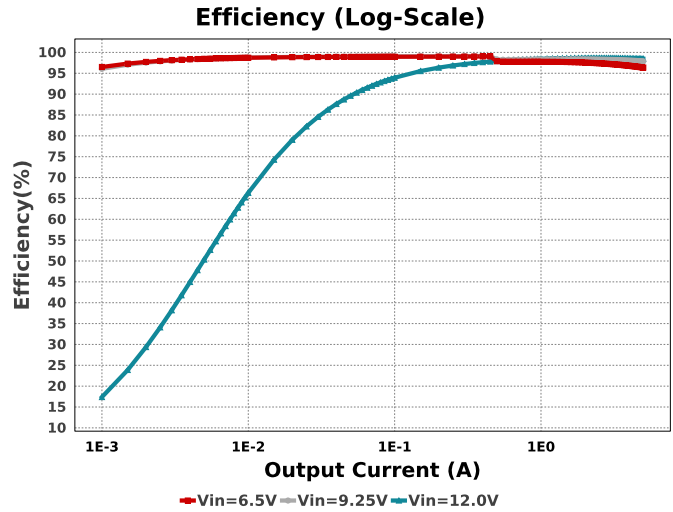
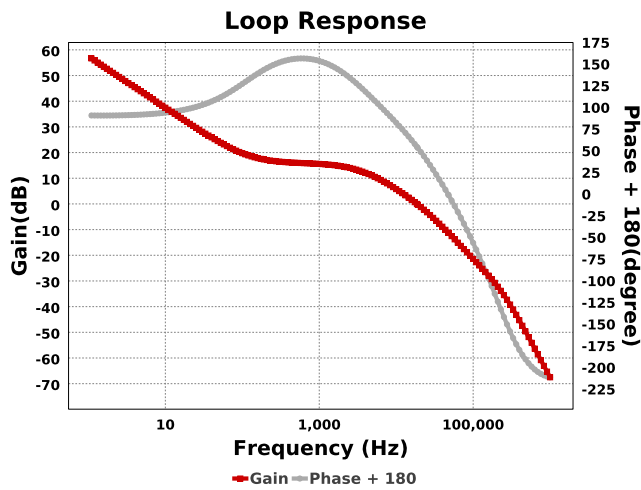

## Operating Values

#	Name	Value	Category	Description
1.	Cin ESR	5.463 mOhm	Capacitor	Cin Capacitor ESR
2.	Cin IRMS	511.912 mA	Capacitor	Input capacitor RMS ripple current
3.	Cin Pd	1.432 mW	Capacitor	Input capacitor power dissipation
4.	Cinx ESR	1.0 μOhm	Capacitor	Cin Capacitor ESR
5.	Cinx IRMS	10.332 mA	Capacitor	Bulk capacitor RMS ripple current
6.	Cinx Pd	106.75 pW	Capacitor	Bulk capacitor power dissipation
7.	Cout ESR	1.581 mOhm	Capacitor	Cout Capacitor ESR
8.	IC Ipk	10.35 A	IC	Peak switch current in IC
9.	IC Pd	1.451 W	IC	IC power dissipation
10.	IC Tj	78.762 degC	IC	IC junction temperature
11.	IC Tolerance	12.0 mV	IC	IC Feedback Tolerance
12.	ICThetaJA Effective	33.6 degC/W	IC	Effective IC Junction-to-Ambient Thermal Resistance
13.	Iin Avg	9.578 A	IC	Average input current
14.	Ipp percentage	18.888 %	Inductor	Inductor ripple current percentage (with respect to average inductor current)
15.	L Ipp	1.809 A	Inductor	Peak-to-peak inductor ripple current
16.	L Pd	769.58 mW	Inductor	Inductor power dissipation
17.	L1 DCR	8.6 mOhm	Inductor	L1 DCR
18.	L1 Irms	9.46 A	Inductor	Inductor ripple current
19.	Cin Pd	1.432 mW	Power	Input capacitor power dissipation
20.	Cinx Pd	106.75 pW	Power	Bulk capacitor power dissipation
21.	IC Pd	1.451 W	Power	IC power dissipation
22.	L Pd	769.58 mW	Power	Inductor power dissipation
23.	Total Pd	2.258 W	Power	Total Power Dissipation
24.	BOM Count	15	System	Total Design BOM count
25.	Cross Freq	11.265 kHz	System	Bode plot crossover frequency
26.	Duty Cycle	47.063 %	System	Duty cycle
27.	Efficiency	96.373 %	System	Steady state efficiency
28.	FootPrint	342.0 mm <sup>2</sup>	System	Total Foot Print Area of BOM components
29.	Frequency	500.0 kHz	System	Switching frequency
30.	Gain Marg	-9.473 dB	System	Bode Plot Gain Margin
31.	Iout	5.0 A	System	Iout operating point
32.	Iout transient step used 2.5 A for Cout calculations		System	Custom Transient current step requirement that was used for Cout selection (A).
33.	Low Freq Gain	53.46 dB	System	Gain at 1Hz
34.	Mode	CCM	System	Conduction Mode
35.	Overshoot Value	14.108 mV	System	Theoretical Vout Overshoot Value
36.	Phase Marg	64.829 deg	System	Bode Plot Phase Margin
37.	Pout	60.0 W	System	Total output power

#	Name	Value	Category	Description
38.	Total BOM	NA	System Information	Total BOM Cost
39.	Undershoot Value	15.443 mV	System Information	Theoretical Vout Undershoot Value
40.	Vin	6.5 V	System Information	Vin operating point
41.	Vin p-p	89.476 mV	System Information	Peak-to-peak input voltage
42.	Vout	12.07 V	System Information	Operational Output Voltage
43.	Vout Actual	12.07 V	System Information	Vout Actual calculated based on selected voltage divider resistors
44.	Vout Ripple requirement used for Cout calculations	1.0 %	System Information	Custom maximum output ripple requirement that was used for Cout selection(% of Vout).
45.	Vout Tolerance	3.958 %	System Information	Vout Tolerance based on IC Tolerance (no load) and voltage divider resistors if applicable
46.	Vout p-p	100.717 mV	System Information	Peak-to-peak output ripple voltage
47.	Vout transient requirement used for Cout calculations	3.0 %	System Information	Custom Transient voltage change requirement that was used for Cout selection (% of Vout).

## Design Inputs

Name	Value	Description
Iout	5.0	Maximum Output Current
VinMax	12.0	Maximum input voltage
VinMin	6.5	Minimum input voltage
Vout	12.0	Output Voltage
base_pn	TPS61288	Base Product Number
source	DC	Input Source Type
Ta	30.0	Ambient temperature

## WEBENCH® Assembly

### Component Testing

Some published data on components in datasheets such as Capacitor ESR and Inductor DC resistance is based on conservative values that will guarantee that the components always exceed the specification. For design purposes it is usually better to work with typical values. Since this data is not always available it is a good practice to measure the Capacitance and ESR values of  $C_{in}$  and  $C_{out}$ , and the inductance and DC resistance of L1 before assembly of the board. Any large discrepancies in values should be electrically simulated in WEBENCH to check for instabilities and thermally simulated in WebTHERM to make sure critical temperatures are not exceeded.

### Soldering Component to Board

If board assembly is done in house it is best to tack down one terminal of a component on the board then solder the other terminal. For surface mount parts with large tabs, such as the DPAK, the tab on the back of the package should be pre-tinned with solder, then tacked into place by one of the pins. To solder the tab down to the board place the iron down on the board while resting against the tab, heating both surfaces simultaneously. Apply light pressure to the top of the plastic case until the solder flows around the part and the part is flush with the PCB. If the solder is not flowing around the board you may need a higher wattage iron (generally 25W to 30W is enough).

### Initial Startup of Circuit

It is best to initially power up the board by setting the input supply voltage to the lowest operating input voltage 6.5V and set the input supply's current limit to zero. With the input supply off connect up the input supply to  $V_{in}$  and GND. Connect a digital volt meter and a load if needed to set the minimum load of the design from  $V_{out}$  and GND. Turn on the input supply and slowly turn up the current limit on the input supply. If the voltage starts to rise on the input supply continue increasing the input supply current limit while watching the output voltage. If the current increases on the input supply, but the voltage remains near zero, then there may be a short or a component misplaced on the board. Power down the board and visually inspect for solder bridges and recheck the diode and capacitor polarities. Once the power supply circuit is operational then more extensive testing may include full load testing, transient load and line tests to compare with simulation results.

### Load Testing

The setup is the same as the initial startup, except that an additional digital voltmeter is connected between  $V_{in}$  and GND, a load is connected between  $V_{out}$  and GND and a current meter is connected in series between  $V_{out}$  and the load. The load must be able to handle at least rated output power + 50% ( 7.5 watts for this design). Ideally the load is supplied in the form of a variable load test unit. It can also be done in the form of suitably large power resistors. When using an oscilloscope to measure waveforms on the prototype board, the ground leads of the oscilloscope probes should be as short as possible and the area of the loop formed by the ground lead should be kept to a minimum. This will help reduce ground lead inductance and eliminate EMI noise that is not actually present in the circuit.

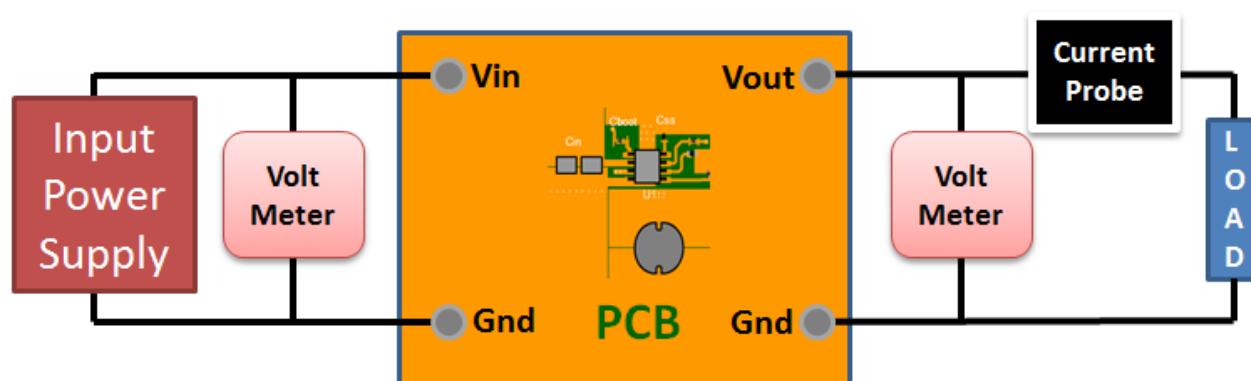

### Design Assistance

1. Master key : 800B893B7489BA7A7EF2B387B716D981[v1]
2. **TPS61288** Product Folder : <https://www.ti.com/product/TPS61288> : contains the data sheet and other resources.

#### Important Notice and Disclaimer

TI provides technical and reliability data (including datasheets), design resources (including reference designs), application or other design advice, web tools, safety information, and other resources AS IS and with all faults, and disclaims all warranties. These resources are intended for skilled developers designing with TI products. You are solely responsible for (1) selecting the appropriate TI products for your application, (2) designing, validating and testing your application, and (3) ensuring your application meets applicable standards, and any other safety, security, or other requirements.

These resources are subject to change without notice. TI grants you permission to use these resources only for development of an application that uses the TI products described in the resource. Other reproduction and display of these resources is prohibited. No license is granted to any other TI intellectual property right or to any third party intellectual property right. TI disclaims responsibility for, and you will fully indemnify TI and its representatives against, any claims, damages, costs, losses, and liabilities arising out of your use of these resources.

Providing these resources does not expand or otherwise alter TI's applicable Terms of Sale or other applicable terms available either on ti.com or provided in conjunction with TI products.