

BUCK REGULATOR FOR Core VOLTAGE 0.8V@80A

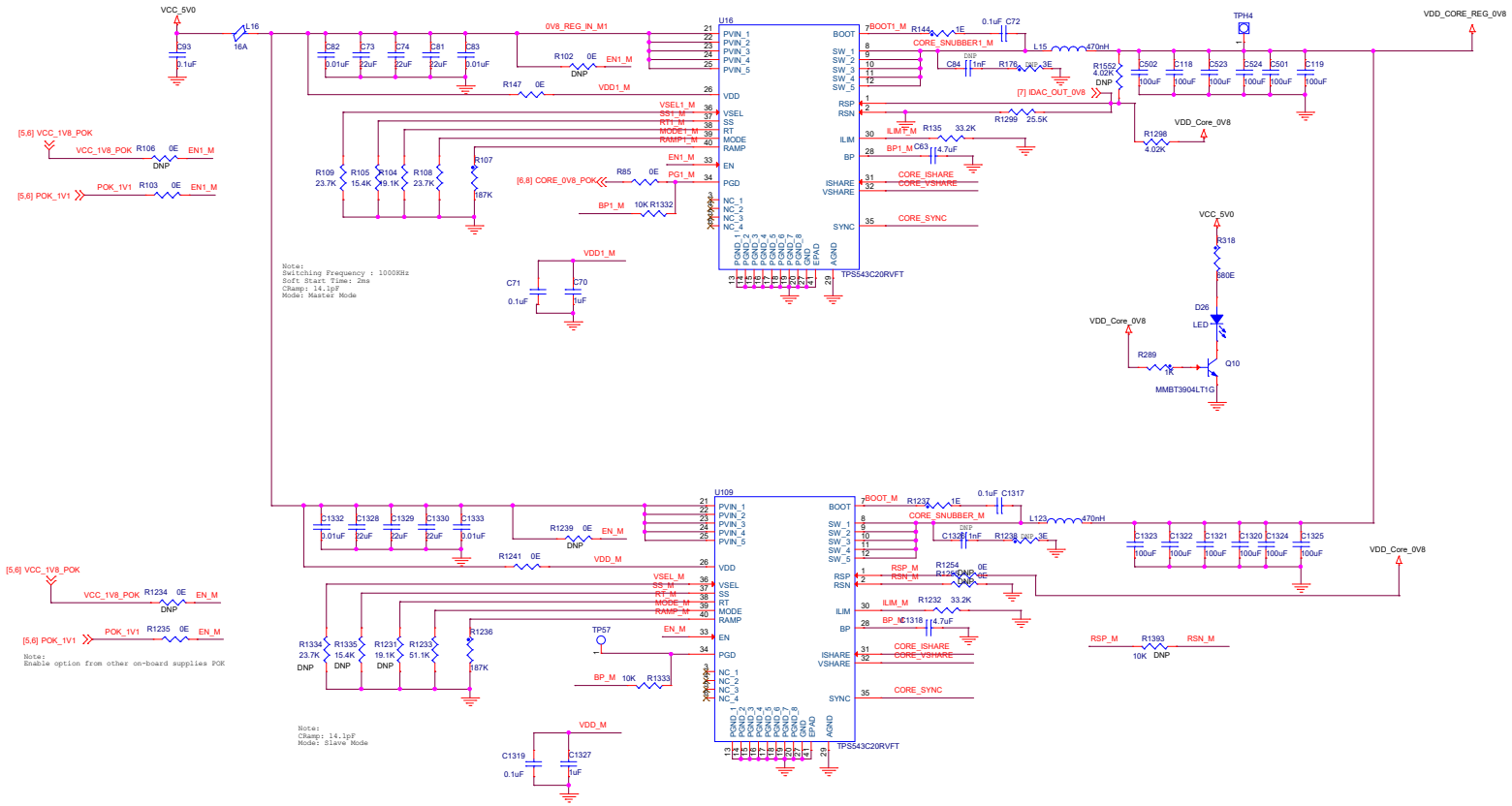

ADC for 0.8V Core Supply Power Measurement

Current DAC for Varying 0.8V core supply

