

**Power rail : VPWR**  
**Controller : UCC2897APWR**  
**VIN : 24V**  
**VOU : 48V**  
**IMAX : 1.25A**  
**Fswitch = 254KHz**

Iin:2.7A

SUMIDA 10393-T167  
 Inductance: 72uH (1,2-5,6)  
 RDC: 20mOhm Max. (1,2-5,6)  
 RDC: 225mOhm Max. (3-4)  
 RDC: 160mOhm Max. (12-7)  
 TURNS RATIO: 1:5 (1,2-5,6):(12-7)  
 TURNS RATIO: 1:1.33 (1,2-5,6):(3-4)  
 HI-POI: ACL3KVMms

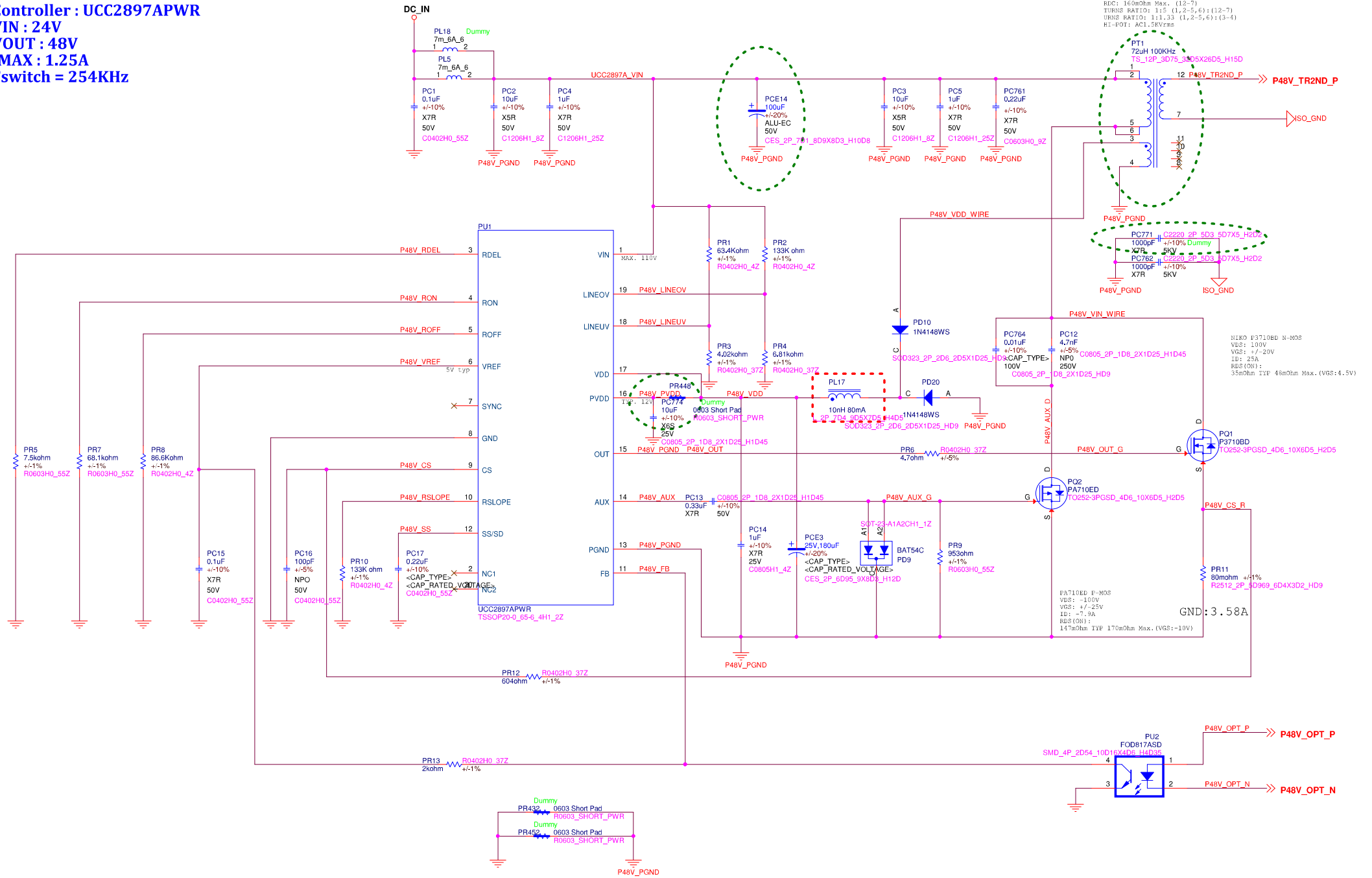

GND: 3.58A

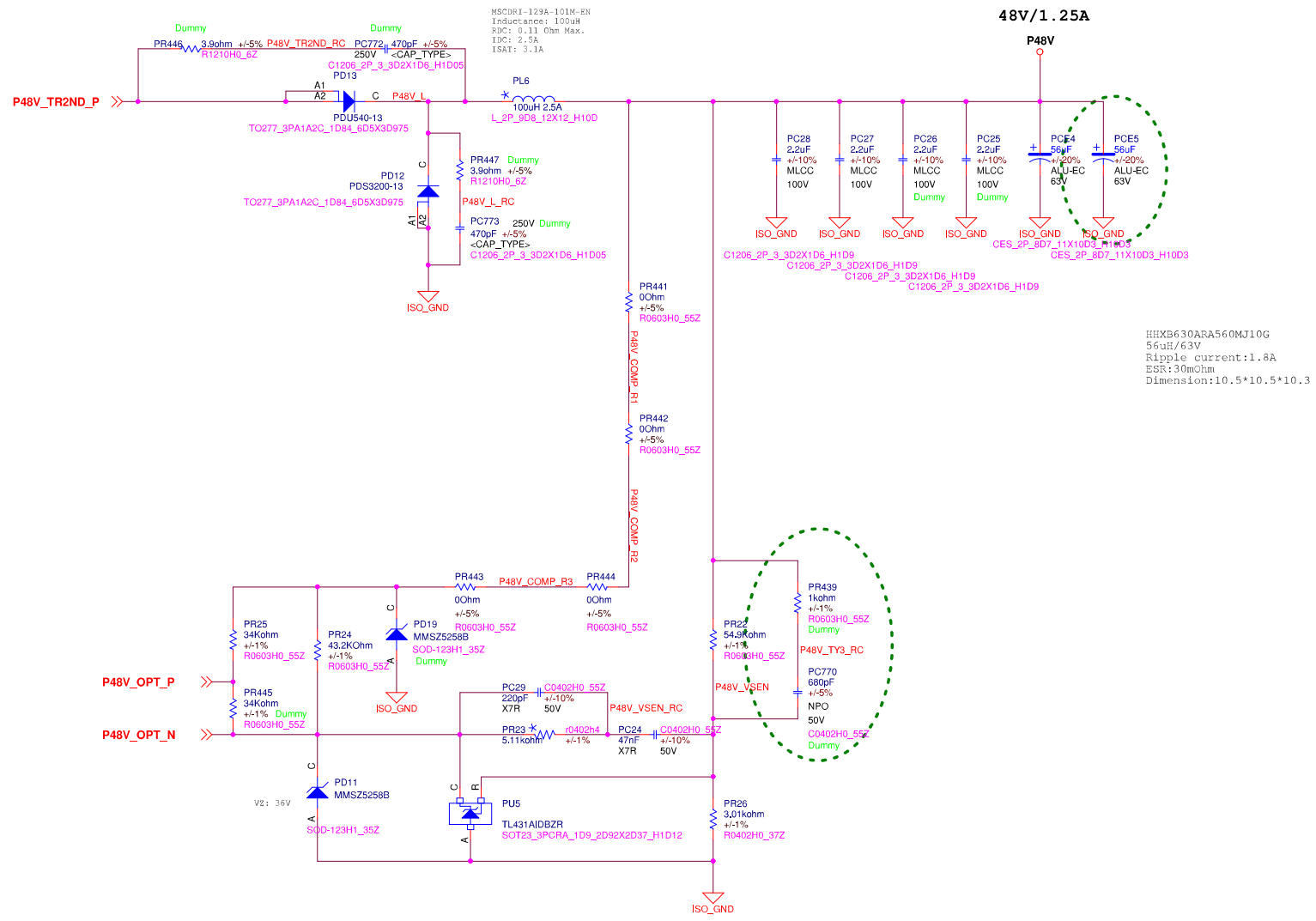

5 4 3 2 1

5 4 3 2 1

C  
B  
A

C  
B  
A