

# POWER & RF

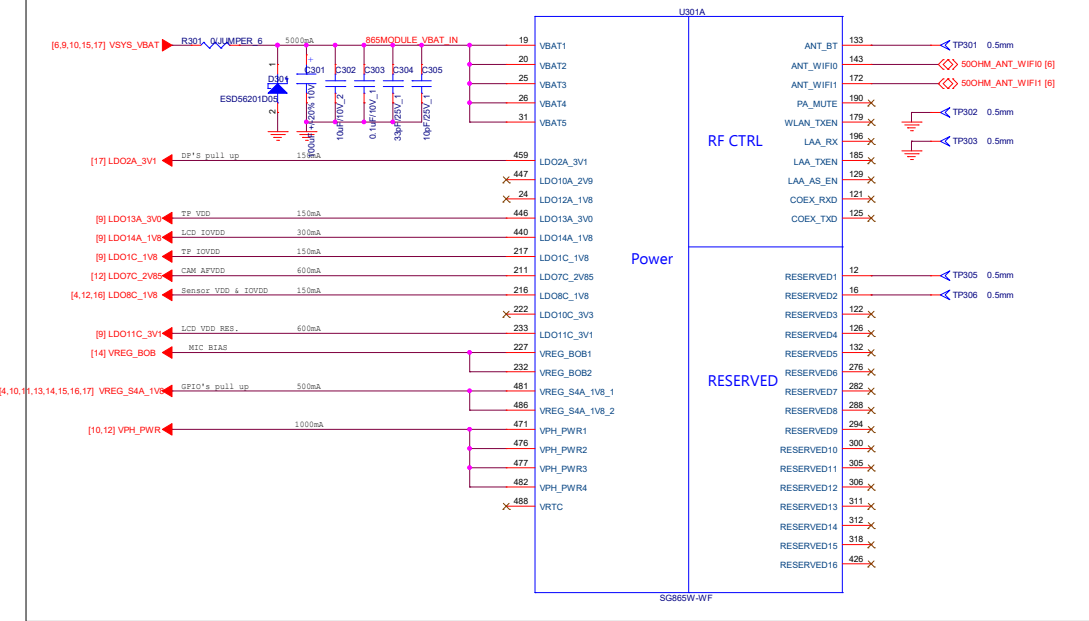

# USB

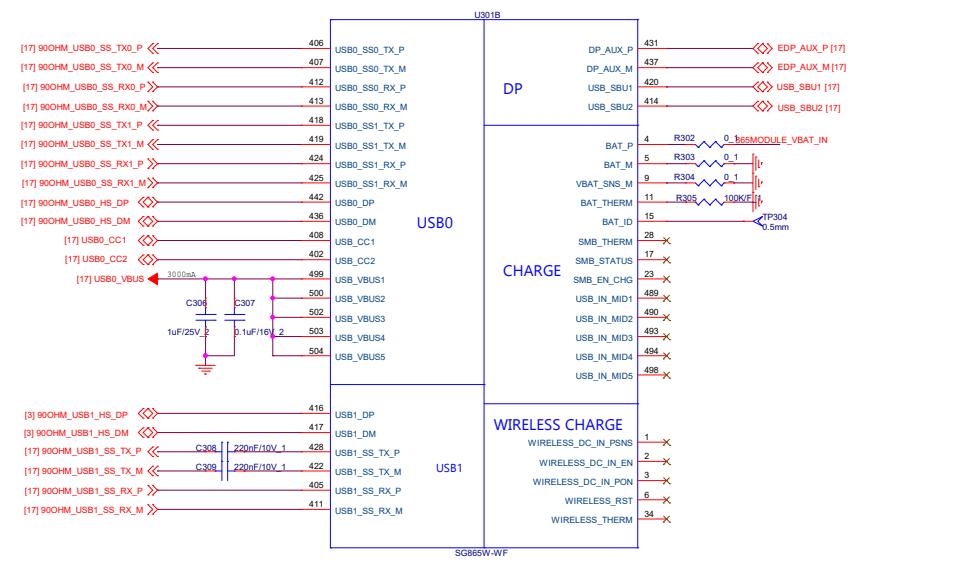

# AUDIO & PCIE

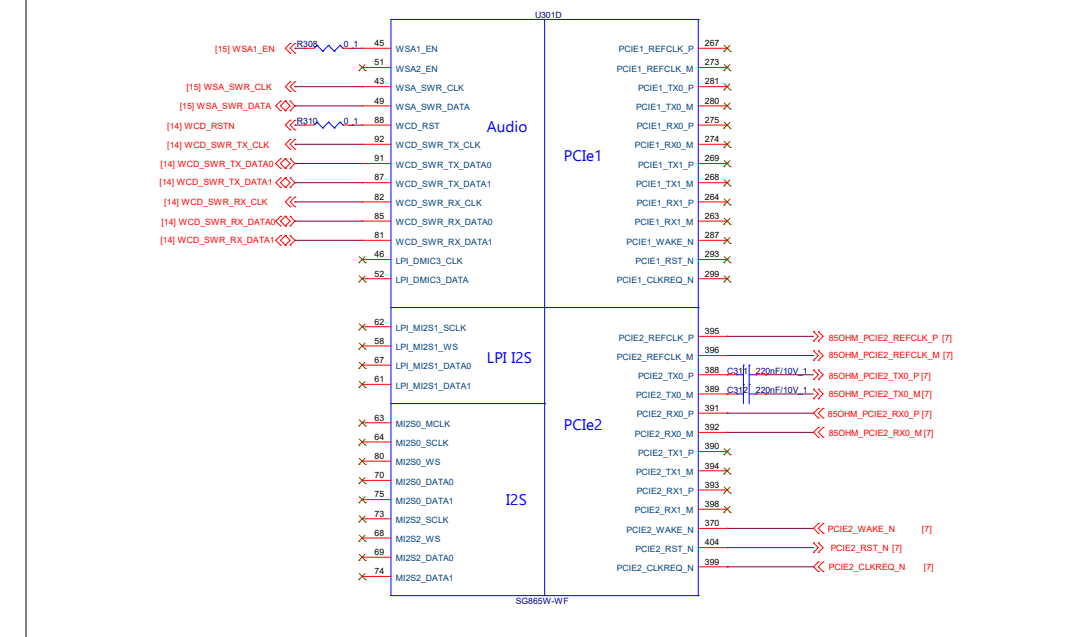

# LED & SD & KEY & DEBUG

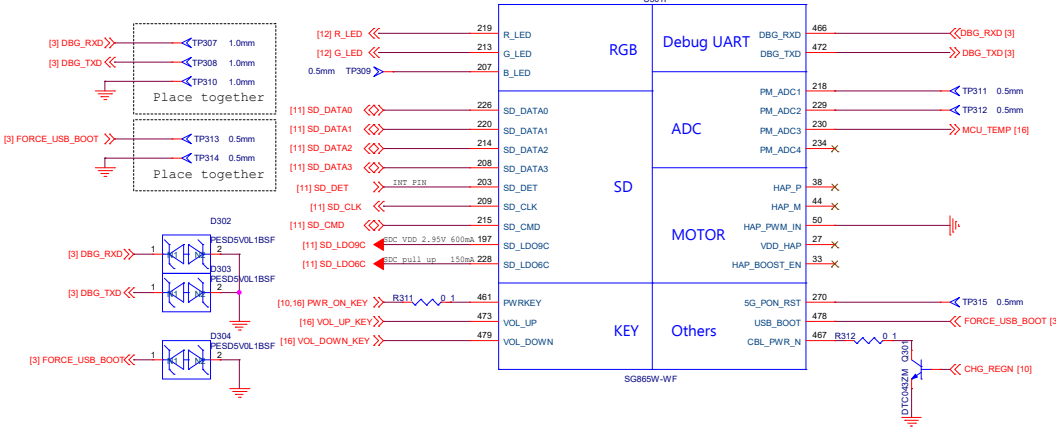

# USB-C CHARGE

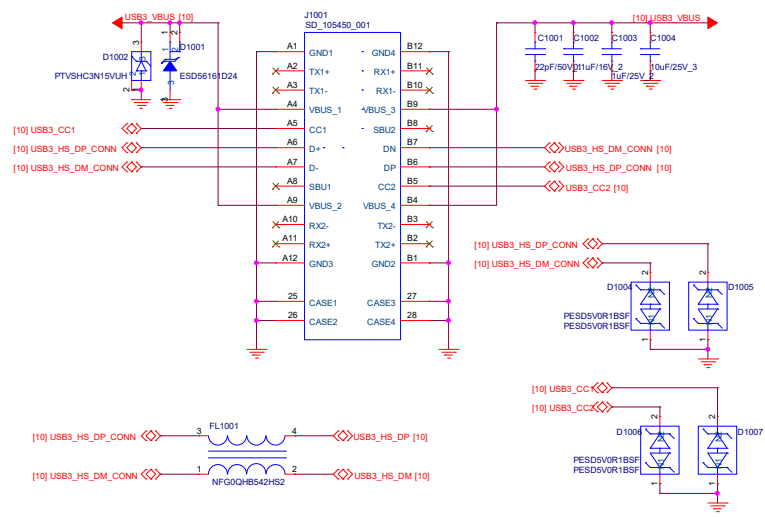

# CHARGE IC

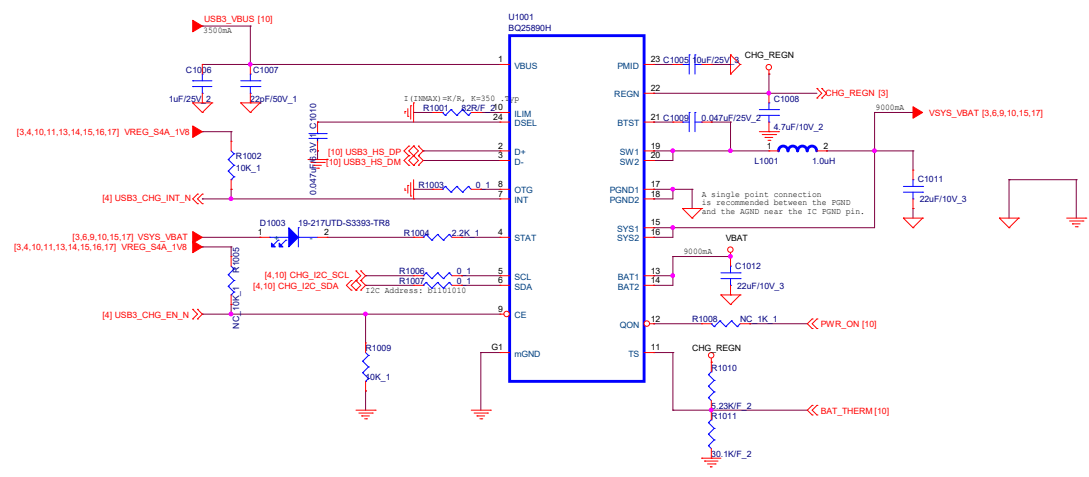

# Fuel Gauge

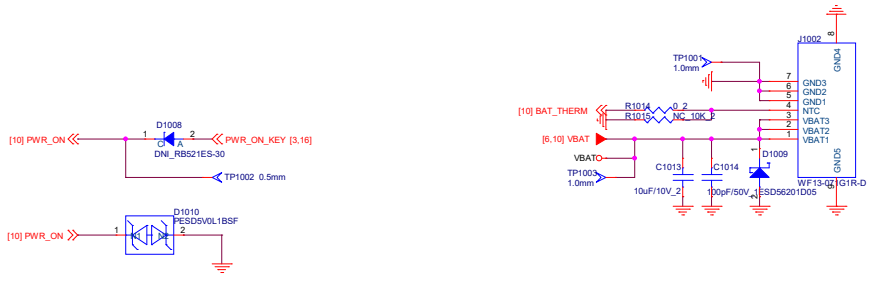
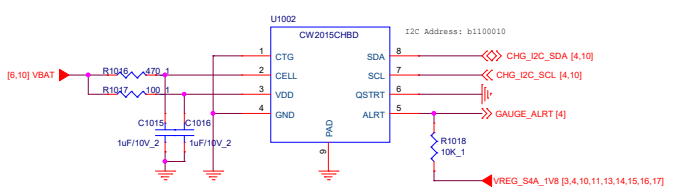

# CHARGE DNI

