

NC R26 and R25=10K: Disable temperature detect
 NC R25 and R26=103AT-2: 0.1°C to 45.1°C
 Connect JP1: Disable charging

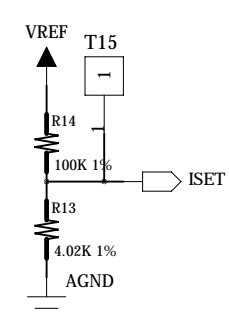

Setting charge current = 638mA
 Setting precharge current = 63.8mA

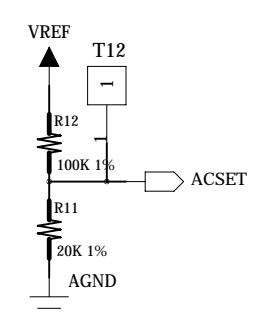

Setting VCC_IN current <= 1.375A

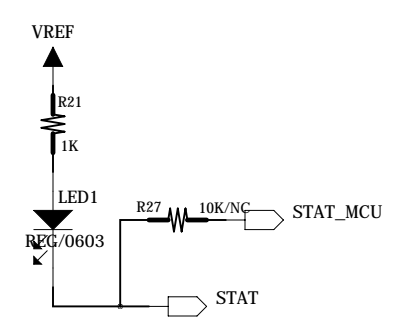

Lighted: Charge in progress
 Unlighted: Charge is complete or in SLEEP mode
 Blinking: Charge suspend

