

NOTE 1: Place close to VIN pin
 NOTE 2: Failure voltage 24V to 30V
 NOTE 3: Failure voltage 5V

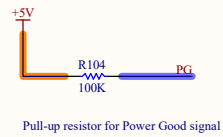

Title: Power Supply		
Size: A4	Number: 1	Revision: 1.0
Date: 14/03/2024	Sheet 1 of 9	
File: 01 - Power Supply.SchDoc		

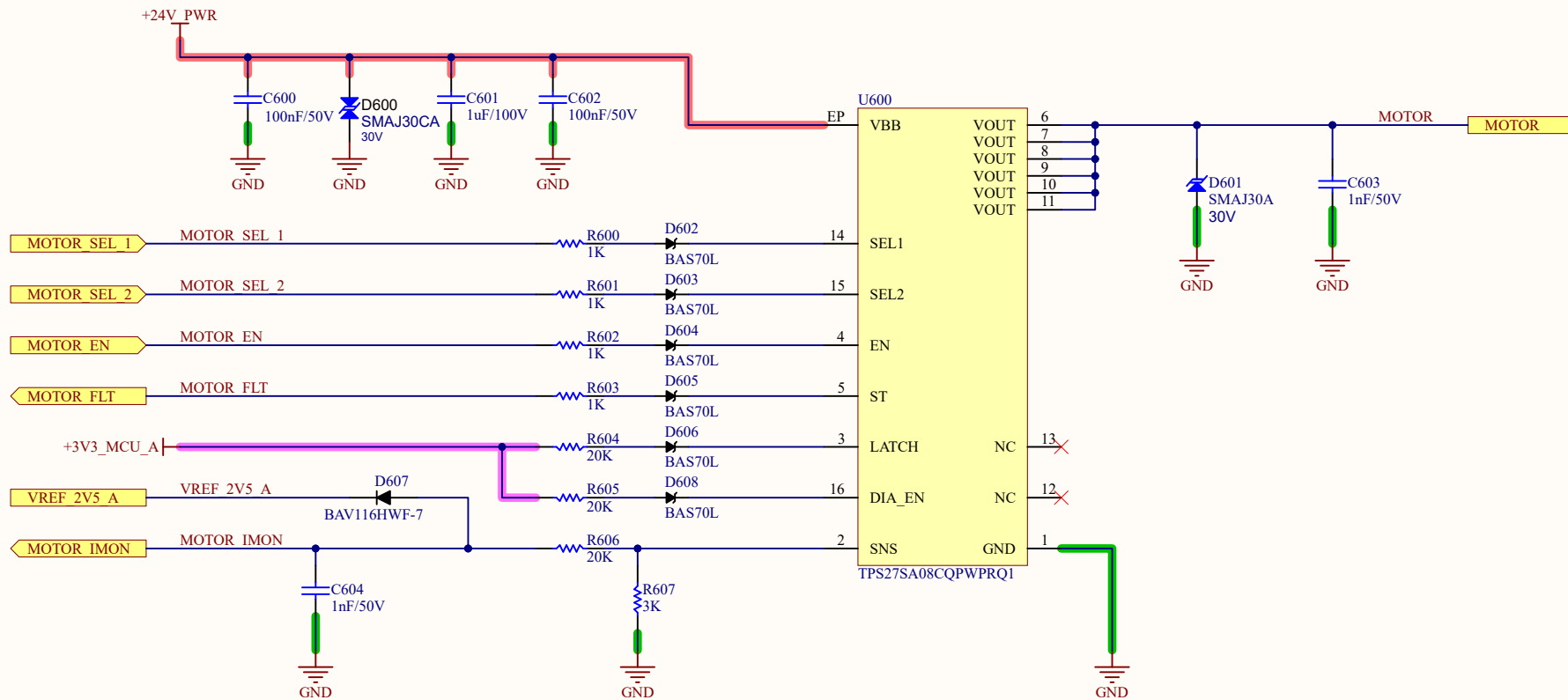

Title: Motor driver			microcomp.
Size: A4	Number: *	Revision: *	
Date: 14/03/2024	Sheet 6 of 10		
File: 06 - DC Motor Driver.SchDoc			