



UCC25600EVM-644
TEXAS INSTRUMENTS

[Buy Now](#)



Looking for a discount?

[Check out our current promotions!](#)

Give us a call

1-855-837-4225

International: 1-415-281-3866

Email Us

Sales and New Orders: sales@verical.com

Order Support: support@verical.com

Suppliers: [Visit our seller page](#)

Company Address

Arrow Electronics, Inc
9201 East Dry Creek Road
Centennial, CO 80112

A 600-W, Isolated PFC Power Supply for AVR Amplifiers Based on the TAS5630 and TAS5631

User's Guide



Literature Number: SLOU293C
June 2010–Revised September 2012



WARNING

Always follow TI's set-up and application instructions, including use of all interface components within their recommended electrical rated voltage and power limits. Always use electrical safety precautions to help ensure your personal safety and the safety of those working around you. Contact TI's Product Information Center <http://support/ti.com> for further information.

Save all warnings and instructions for future reference.

Failure to follow warnings and instructions may result in personal injury, property damage, or death due to electrical shock and/or burn hazards.

The term TI HV EVM refers to an electronic device typically provided as an open framed, unenclosed printed circuit board assembly. It is intended strictly for use in development laboratory environments, solely for qualified professional users having training, expertise, and knowledge of electrical safety risks in development and application of high-voltage electrical circuits. Any other use and/or application are strictly prohibited by Texas Instruments. If you are not suitably qualified, you should immediately stop from further use of the HV EVM.

1. Work Area Safety:

- (a) Keep work area clean and orderly.
- (b) Qualified observer(s) must be present anytime circuits are energized.
- (c) Effective barriers and signage must be present in the area where the TI HV EVM and its interface electronics are energized, indicating operation of accessible high voltages may be present, for the purpose of protecting inadvertent access.
- (d) All interface circuits, power supplies, evaluation modules, instruments, meters, scopes and other related apparatus used in a development environment exceeding 50 V_{RMS}/75 VDC must be electrically located within a protected Emergency Power Off (EPO) protected power strip.
- (e) Use a stable and non-conductive work surface.
- (f) Use adequately insulated clamps and wires to attach measurement probes and instruments. No freehand testing whenever possible.

2. Heat Sinks:

- (a) Heat Sinks on the board have temperatures greater than 50°C while the board is energized.
- (b) It is advisable to give some time for the heat sinks to cool off after the board has been de-energized before handling.



WARNING

3. Electrical Safety:

- (a) De-energize the TI HV EVM and all its inputs, outputs, and electrical loads before performing any electrical or other diagnostic measurements. Revalidate that TI HV EVM power has been safely de-energized.
- (b) With the EVM confirmed de-energized, proceed with required electrical circuit configurations, wiring, measurement equipment hook-ups and other application needs, while still assuming the EVM circuit and measuring instruments are electrically live.
- (c) Once EVM readiness is complete, energize the EVM as intended.

WARNING: while the EVM is energized, never touch the EVM or its electrical circuits as they could be at high voltages capable of causing electrical shock hazard.

4. Personal Safety:

- (a) Wear personal protective equipment e.g. latex gloves and/or safety glasses with side shields or protect EVM in an adequate lucent plastic box with interlocks from accidental touch.

5. Limitation for Safe Use:

- (a) EVMs are not to be used as all or part of a production unit.

A 600-W, Isolated PFC Power Supply for AVR Amplifiers Based on the TAS5630 and TAS5631

This user guide documents a low-profile power supply that is suitable for AVR amplifiers or other high power amplifier applications. The power supply accepts an ac line-input voltage (108 VRMS to 265 VRMS), and produces an output voltage of 50-VDC for loads up to 12 A (600 W).

1 Introduction

The power supply is dedicated to Audio applications and more specific the TAS5630/TAS5631 from Texas Instruments. The difference compared to an industrial grade power supply is the typical user pattern of an audio-system. First, music is dynamic with a crest factor typically in the range of 1/10 to 1/5 (Highly compressed music). Second, the user pattern of a normal audio system, runs most of the time in low power mode (<5W) playing "background" music.

This information has been considered when designing the SMPS for the TAS5630.

An explanation of the features and functions has been provided. Indications are provided where the normal procedures regarding power supply design has been modified to accommodate the audio-application.

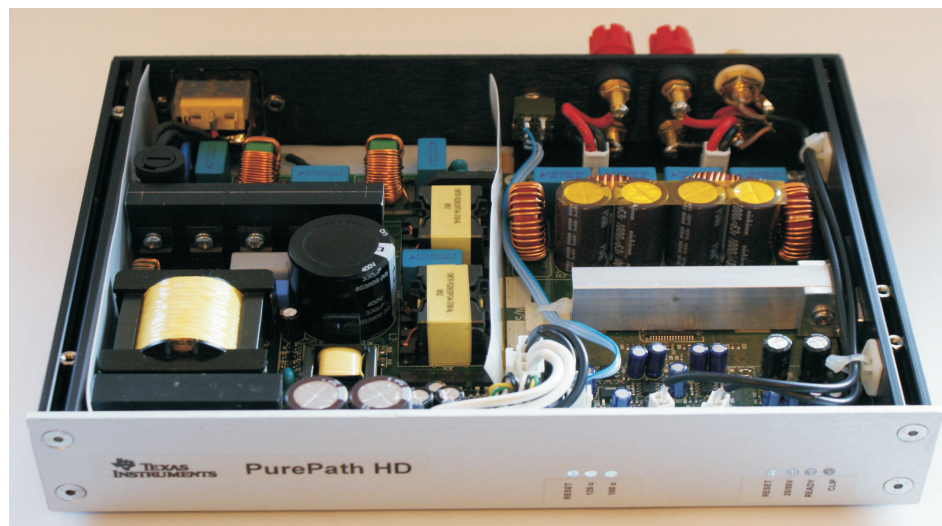

The requirements for a modern AVR include a slim physical profile and the ability to operate from the ac-line input at close to unity power factor. Therefore, an AVR application demands the power supply be of low height, and comply with the power quality requirements defined in the IEC standard, 61000-3-2. In addition, the combination of a tight physical package and the desire to meet Energy Star™ guidelines requires that the design also demonstrates high efficiency. Described herein is a practical design that uses standard components. It achieves the requirements using a traditional two-stage power converter topology along with state-of-the-art power circuit control methods. The first stage is an interleaved, transition-mode, power factor correcting (PFC) boost pre-regulator. This is followed by an isolated LLC series resonant DC-DC main converter.

The design takes advantage of three integrated circuit power controllers.

- The PFC pre-regulator stage is controlled by the UCC28061, a dual-phase, interleaved, transition-mode PFC controller.
- The resonant LLC converter uses the UCC25600; a low-cost 8-pin controller.
- The third IC is the UCC28600. This is used to control a small 6-W flyback converter that provides a bias supply voltage.

2 Scope

This user guide is intended to demonstrate the design of the functional circuit, the operation of which has been verified through a limited number of performance tests. This circuit incorporates essential safety features. These include an input line fuse, inrush current control, output over-current limit, and output over-voltage protection.

Electromagnetic compatibility (EMC) has been taken into account during circuit selection and PCB layout design. For most applications, the EMI filter components used are sufficient, but different housing and different harness wiring and amplifier sections demands a need for filter adjustments to meet applicable environmental and system compatibility requirements.

3 Electrical Performance

Table 1. Electrical Performance⁽¹⁾⁽²⁾⁽³⁾

PARAMETER		CONDITIONS	MIN	TYP	MAX	UNITS
INPUT CHARACTERISTIC						
V_I	Input Voltage		108		265	V_{rms}
F	Line frequency		48		65	Hz
I_I	Input current				8	A_{rms}
p.f.	Power factor		0.95			
OUTPUT CHARACTERISTIC						
	PFC Stage:					
$V_{O(HVDC)}$	Output voltage			390		V_{dc}
	LLC resonant stage:					
$V_{I(HVDC)}$	Input voltage		330		410	V_{dc}
V_O	Output voltage			50		
I_O	Output current		1		12	A
$I_{O, peak}$	Peak output current				20	
P_O	Output power	Continuously		250		W
		Maximum for 5min		600		
		Peak 20mS		1000		
I_{LIM}	Current limit			26		A
P_{LIM}	Power limit			700		W
di/dt	Output current slew rate	Do not exceed maximum slew rate			11	A
					200	ms
SYSTEM CHARACTERISTIC						
η	Full load efficiency	110 V_{ac} , 80% load		88%		
η	Nom load efficiency	230 V_{ac} , 50% load		91%		
t_{HOLD}	Hold-up time	Nominal V_I , 20% load	20			ms
OV_{THLD}	Over-voltage threshold	OV shutdown and restart		55		V
	Temperature range	National Conv airflow	0		50	°C

⁽¹⁾ Operates down to zero load with reduced regulation.

⁽²⁾ Forced Air cooling can be needed depending on the housing in which the SMPS is used – the temperature warning open drain output signal can be used to control a fan.

⁽³⁾ The 50-V output will not power up, unless the ± 15 -V outputs are loaded. It is recommended that you load these outputs with 75 Ω during power up.

4 Overall System Description

4.1 System Block Diagram

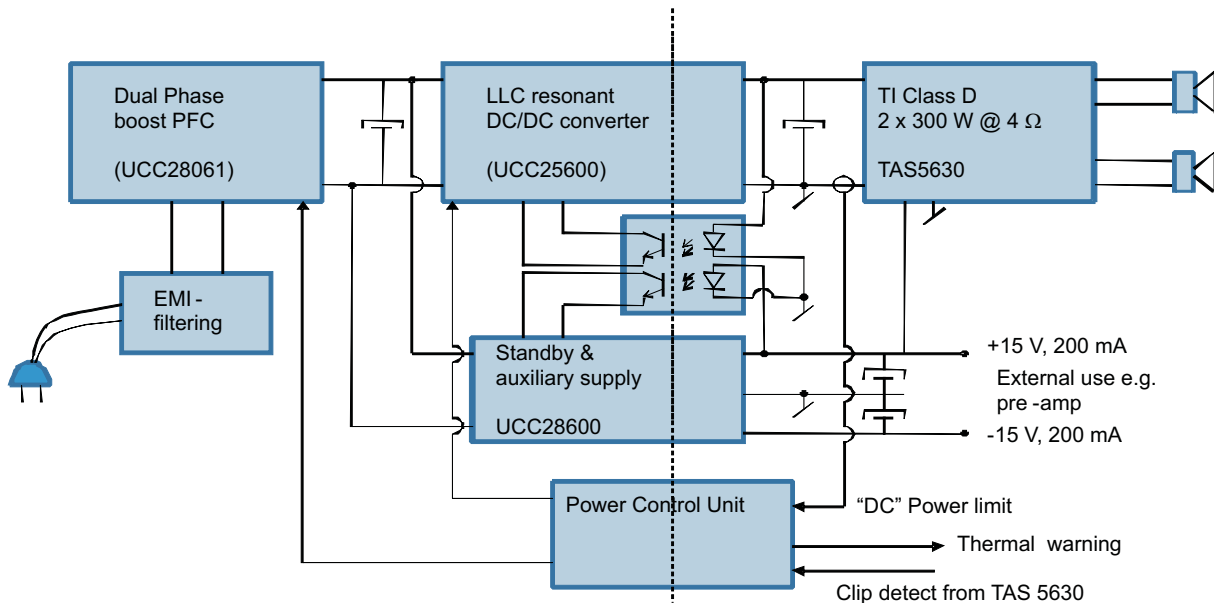

Figure 1. System Block Diagram

The system incorporates 3 power converters:

1. PFC Boost front end based on the UCC28061. This converter is a dual interleaved boost converter operating in the Boundary Conduction Mode.
2. A DC/DC converter for the main power based on the UCC25600. This is a LLC-resonant half bridge converter capable of both zero-current and zero-voltage switching.
3. An auxiliary converter with low power stand-by functionality based on the UCC28600. The converter supplies both the primary side circuits as well as the amplifier module and furthermore, the $\pm 15\text{V}$ supply is made available for powering any preamp or other surrounding circuits supporting the audio power system.

The basic functionalities of the system is:

1. Overcurrent protection ($\pm 15\text{V}$ and 50V outputs)
2. Overtemperature indication (open collector output)
3. Automatic standby mode
4. Switchable output voltage ($50\text{V}/25\text{V}$ – the output voltage setting is controlled by the clip-detect pin)

4.2 Overcurrent Protection (OCP)

4.2.1 Main DC/DC Converter (OCP)

There are 2 different current protection modes in the main DC/DC converter.

The first mode is primary-side detection and the main purpose of this insures that a fault condition on the 50V rail is not destructive.

The current sensing is done by rectifying and filtering the ac-voltage across the resonant capacitor. The UCC25600 controller IC has a comparator input that senses this voltage and if the voltage exceeds 1V, the UCC25600 turns off both MOSFETs, resets the soft-start capacitor and initiates a start sequence. The converter repeats this step until the fault condition is no longer present.

Since the converter is able to supply peak powers above 1 kW but is not thermally designed for this function, an average power measurement was implemented. By measuring the average output current on the secondary side rail, an indication of the power level can be established.

The converter should be allowed to supply an average power of approximately 700W. This should ensure that the amplifier module can deliver 600W.

4.2.2 Auxiliary Converter (OVP)

The auxiliary converter is controlled by the UCC28600 which uses peak current control. The primary side current is measured and if this current reaches the OC-level, the supply shuts down and initiates a start-up sequence. This prevents any faulty conditions on the $\pm 15V$ rail to be destructive.

4.3 Overtemperature Protection

The system has 1 thermal sensor on the PC board located near the Anode of the diode D8.

The sensor is the TMP300 and the trip-temperature can be adjusted by a resistor (R48). In the described design this temperature is approximately 90°C. The TMP300 has an open drain output that is pinned out on the board. The TMP300 also supplies an analog voltage that can be translated into a temperature – available at J4 pin 2.

For a thermal indication, the user should react – either by lowering the amplifier output power or by shutting down. It is possible to connect the thermal indicator pin directly to the clip-detect pin. This lowers the rail voltage to 25V and reduces output power.

The thermal protection should be tested in the final product and the user should consider if a primary side thermal sensor should be applied to the semiconductors.

4.4 Standby

The UCC28600 supplies the bias power to the PFC and DC/DC converter. When the power consumption on the $\pm 15V$ rails falls below approx. 1.5W, the UCC28600 turns off the bias power to the main power converters and enters low power/standby mode.

During this mode the $\pm 15V$ is "alive" but the main power rail (50V/25V) is off. When power consumption on the auxiliary voltages goes up again the main power rail is turned on.

4.5 Switchable Rail Voltage

The power supply rail voltage has 2 different settings which are controlled by the clip-detect pin.

During low power situations where 25V rail voltage is sufficient, the system turns off the PFC converter and only uses the DC/DC converter.

At high line (230VAC) and in this mode, the main DC/DC converter enters a burst mode operation to be able to regulate the voltage down to 25V. Depending on power level this burst operation produces some acoustical noise. At low line (110VAC) the DC/DC does not enter the burst mode, and therefore, no acoustical noise.

When the clip-detect is pulled high (12V), the PFC converter starts and the rail voltage is regulated up to 50V. If the clip-detect pin goes low again the rail voltage stays at 50V for a few seconds and then slowly ramps down to 25V.

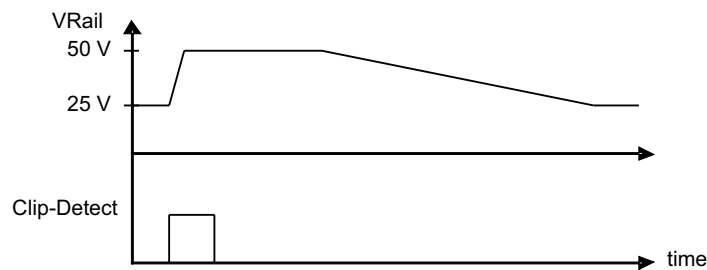

Figure 2. Correlation Between Rail Voltage and Clip-Detect Signal

5 Design Considerations

5.1 Dual Interleaved Boost PFC

The design of the boost PFC converter follows the design guidelines provided by the documentation of the UCC28061. There are a few exceptions that are explained.

First of all, since the load of the power supply in the end, is an audio amplifier, there is a huge difference between what could be called full continuous music power and what is normally understood as full power for a non-dynamic constant load. This reflects on the design of the Magnetics and the thermal performance, and in the choices of semiconductors

5.1.1 Boost Inductors

To get the best performance in terms of highest possible efficiency, it is desirable to let the switching frequency of the boost converter drop to just above the audible limit. But, this also results in a larger boost inductor. To optimize for size and cost, the minimum frequency is set to 60kHz at 85VAC, 700W. For the design, this results in an inductor of 150uH with a Bmax of 350mT.

5.1.2 Control Loop Considerations

For a boundary mode PFC converter, there is only the voltage loop to consider. In a normal PFC design, the bandwidth of the voltage loop is limited to approx 10Hz. Since the object is to obtain a sinusoidal current in phase with the line, the resulting power delivered to the output of the boost converter is pulsating with a frequency twice that of the line frequency (either 120Hz(US) or 100Hz(Europe)). If the bandwidth of the voltage loop was not limited, then the converter tries to regulate this pulsating power, and thereby; destroys the ability to obtain sinusoidal current.

When using PFC together with Audio load, a new problem arises. Since the audio range is typically defined as 20Hz-20kHz, the load seen from the PFC converter can vary with a frequency as low as 40Hz. If applying a normal loop compensation, the PFC converter tries to regulate this 40Hz. If the amplifier is delivering 600Wrms, the peak power is 1000W. This means that the PFC converter tries to deliver this peak power. For this design, the inductors are at the flux density limit when considering full power and low line, and therefore; no headroom to deliver more power without the inductors saturating. The user can design the inductors to cope with this, but the inductors will as much as 2 times in size.

Instead, reduce the cross over frequency to about 3Hz (compensation network C58,C59,R80). The loop gain is sufficient at 40Hz. The result is a slow responding voltage loop with possible voltage overshoots, but since the UCC28061 already has incorporated a feature that protects against the voltage load, there is a larger concern regarding magnetic size.

5.1.3 Start and Stopping the PFC Converter

In the system, the PFC section is enabled/disabled according to the main power rail setting. There are many ways to do this as long as the PFC converter when is enabled using soft start. The optocoupler U9 signals the ON/OFF command to the PFC converter. During OFF, R42 pulls the Vsense (pin 2 on UCC28061) through D12 above the dynamic OVP threshold in the UCC28061. This disables the PFC section and triggers the softstart when the bias from R42 is removed.

5.2 LLC Resonant DC/DC Converter

The design of the resonant converter also general follows the standard procedure shown in the documentation provided together with the UCC25600 but with some alterations based on the demand of the audio application.

5.2.1 LLC Gain

The input voltage to the LLC converter is when the boost converter is running approximately 390 VDC.

This voltage has a significant ripple at full power. The gain of the LLC converter depends on the ratio of transformer magnetizing inductance and resonant induct size together with load and switching frequency.

For this design, the following parameters were calculated:

$$L_M: 170\mu\text{H}, L_R: 30\mu\text{H}, n: 4.6, C_R: 47\text{nF}$$

This gives a resonant frequency of 134kHz. Figure 3 shows the gain curves normalized to the resonant frequency as a function of the output power:

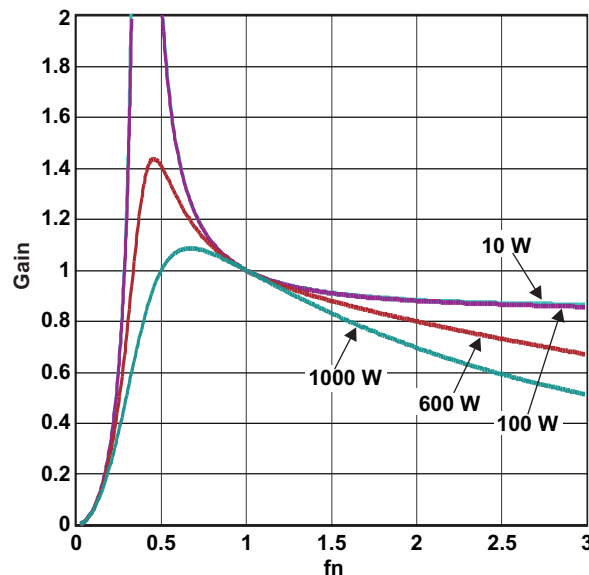

Figure 3. LLC Gain

During high power mode where the rail voltage is 50V, the minimum frequency is clamped to approximately 90kHz. This limit is set by the parallel connection of R36 and R96 (Q12 is ON in this mode). This should ensure enough gain to regulate the output voltage and keep the gain characteristics monotone increasing with lower frequencies until the 90 kHz is reached.

During low power mode where the rail voltage is 25V and the PFC converter disabled, the DC/DC converter needs additional gain at low line to regulate to 25V. During this mode, the transistor Q12 is OFF and the lower frequency limit is given by R36 and is 62kHz.

5.2.2 Transformer and Resonant Inductor Design

For this design, the leakage in the transformer is utilized as the resonant inductor. An external inductor, can be used, but at a higher cost.

The leakage inductor in the transformer is created by un-coupled flux between the primary and secondary side. The user does not have to consider saturation of the inductor since it is to be regarded as an air coil.

It is possible to use chamber bobbins, but to avoid being tied to specific coil former; the transformer is utilized on a standard ETD39 bobbin. The principle is to create space between the primary and secondary windings. The larger the distance, the larger the leakage inductance. The transformer is constructed with a tapped secondary side and these two windings are physically laid side-by-side across the bobbin window, which also adds to leakage.

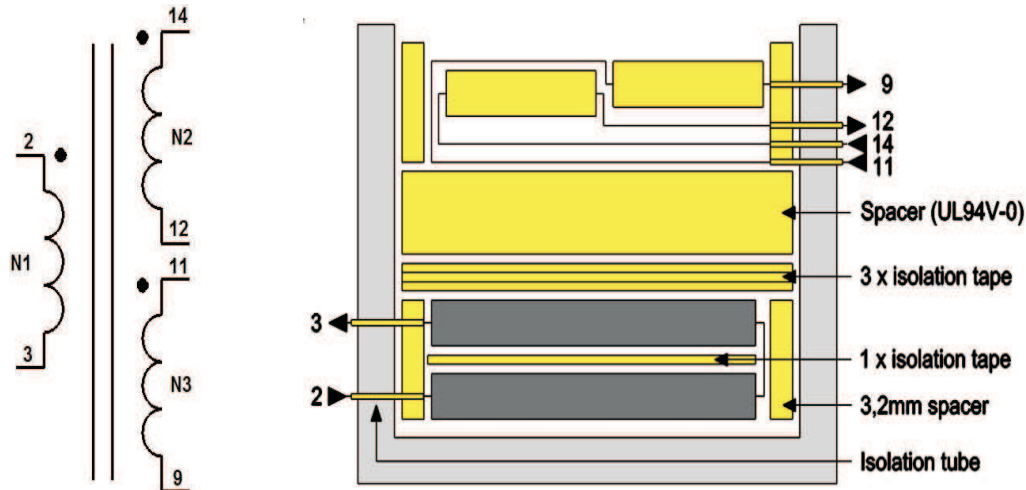

Figure 4. Transformer Construction

5.2.3 Voltage Rail Switching

The feedback loop to regulate the rail voltage uses the optocoupler U8 and the shunt regulator U4. When Q10 is OFF the voltage is regulated to approximately 26V. When the Clip-Detect signal goes high, the gate of Q10 is charged and the transistor turns ON effectively paralleling R37 and R38. At the same time Q17 is turned ON signaling, through the optocoupler U9, to turn ON the PFC converter. When the clip detect signal goes low again, the gate of Q10 is slowly discharged. The rail voltage is kept at 50V until the gate voltage drops into the active region where Q10 starts to behave as a resistor slowly increasing in value. This ensures slow rail voltage ramp down. During this action the boost PFC will shut down as the gate voltage of Q17 reduces to below the threshold.

5.2.4 OVP

The overvoltage protection kicks in at about 53V. The divider of R50 and R53 together with U6 senses the rail voltage and signals through U9 to the primary side. If the OVP is triggered, the current through the optocoupler is sufficiently large to discharge the soft start capacitor C32. The supply restarts using soft start after the rail voltage is below the OVP limit.

5.2.5 Power Limit

The power limited looks at the secondary output current across sense resistors R104 and R105 connected in parallel. The effective resistance of 2.5m Ω gives a low voltage drop maximizing efficiency. The low sense voltage is amplified by U12, a current shunt monitor – INA210, using U7 as reference voltage, and U13 as comparator. The ratio R56/R45 can be used to adjust the current limit.

When the power limit is reached its recommended to switch the output from 50V to 25V or turn down the audio signal in the analog front end.

5.3 Auxiliary Converter

Follows standard design procedure when using the UCC28600.

6 Measurements

6.1 LLC Control Loop Measurement

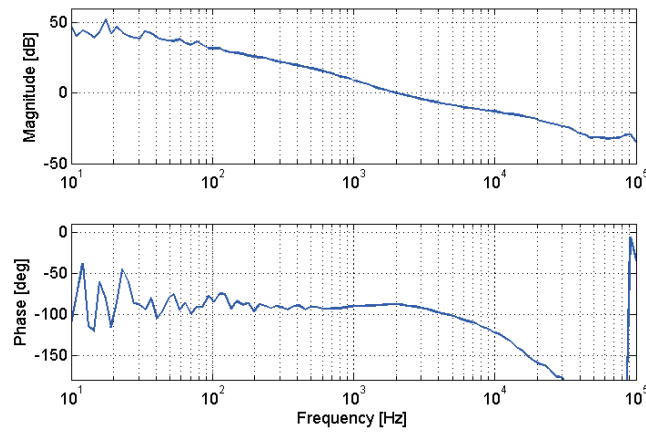

Figure 5. LLC Control Loop

The loop gain is measured at 200W. Bandwidth is 2kHz with a phase margin of 90 degrees.

6.2 System Efficiency

6.2.1 Efficiency at 50V Rail Voltage

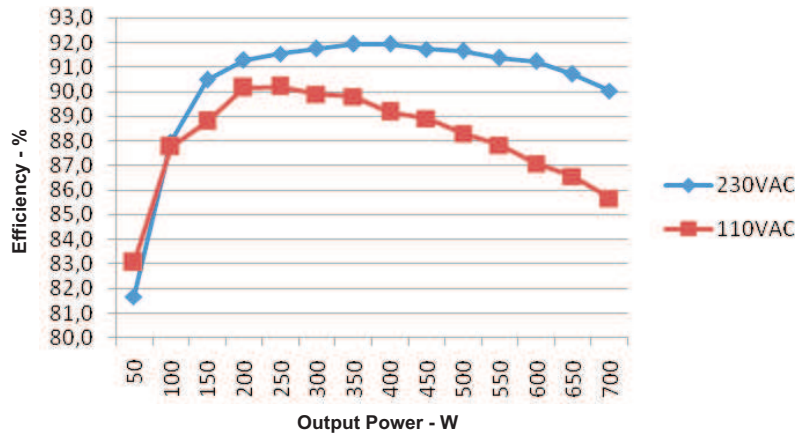

Figure 6. Efficiency at 50V Rail Voltage

The measurement is carried out with forced air on the heat sinks. Power range from 50W to 700W.

6.2.2 Low Power Efficiency at 25V Rail Voltage

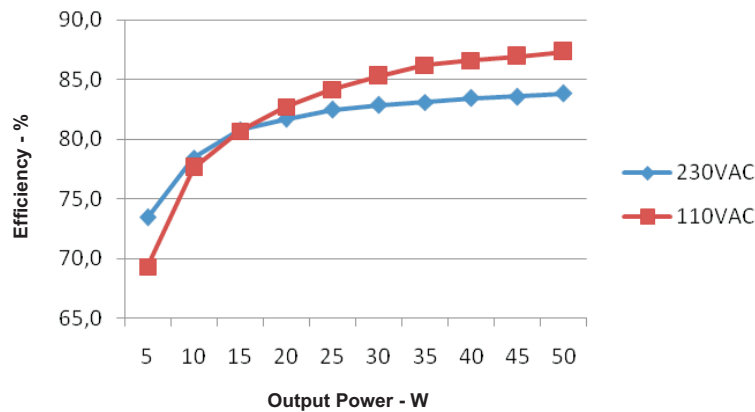

Figure 7. Efficiency at 25V Rail Voltage

Power range is from 0W to 50W

6.2.3 Standby Power

With no load connected to the $\pm 15V$ the standby power consumption is:

- P_standby <700mW at 230VAC
- P_standby <300mW at 110VAC

6.3 EMI Measurements

The measurements are only guidelines, and are not made at a certified lab, but shows that the design is capable of passing the EMI limits if implemented properly.

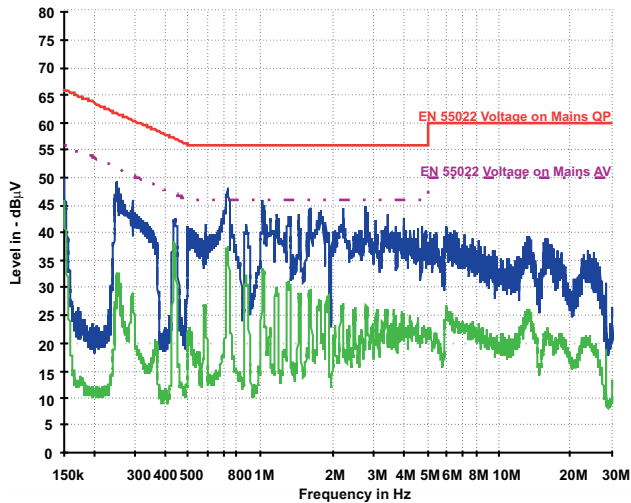

Figure 8. 110Vac – 83W Load – Neutral

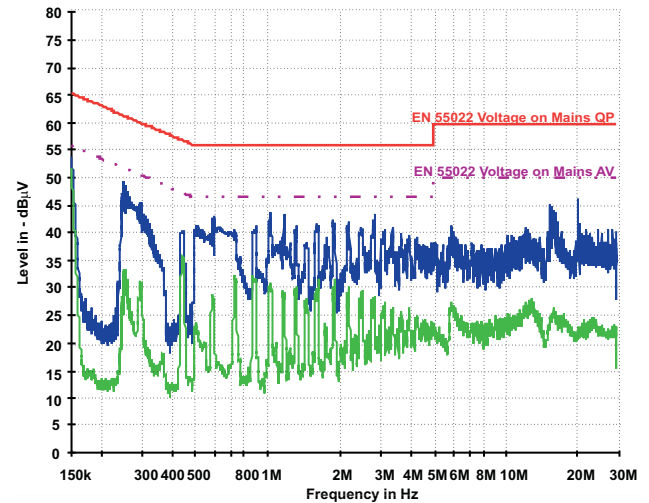

Figure 9. 110Vac – 83W Load – Line

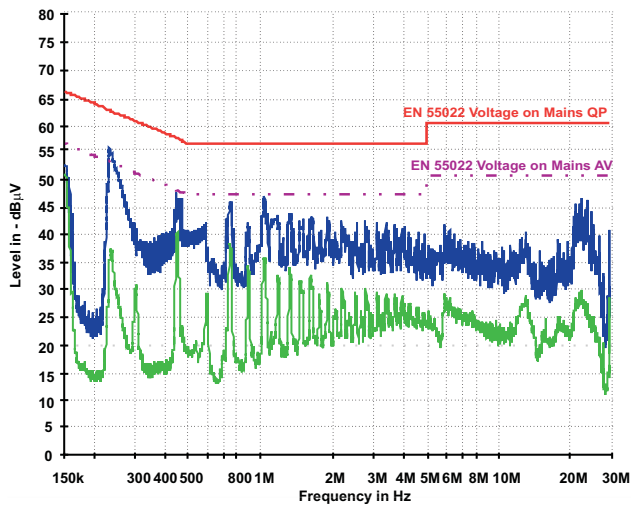

Figure 10. 230Vac – 83W Load – Neutral

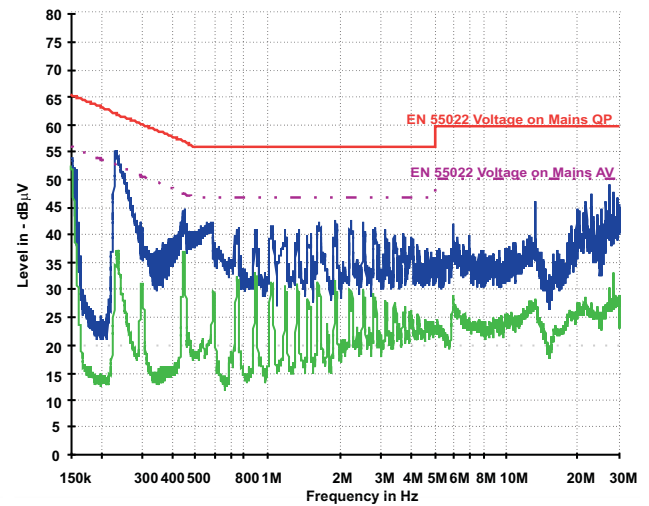

Figure 11. 230Vac – 83W Load – Line

7 Schematics

The schematic is done in Orcad Capture, and the Job file is available for download in the tools folder for the user guide.

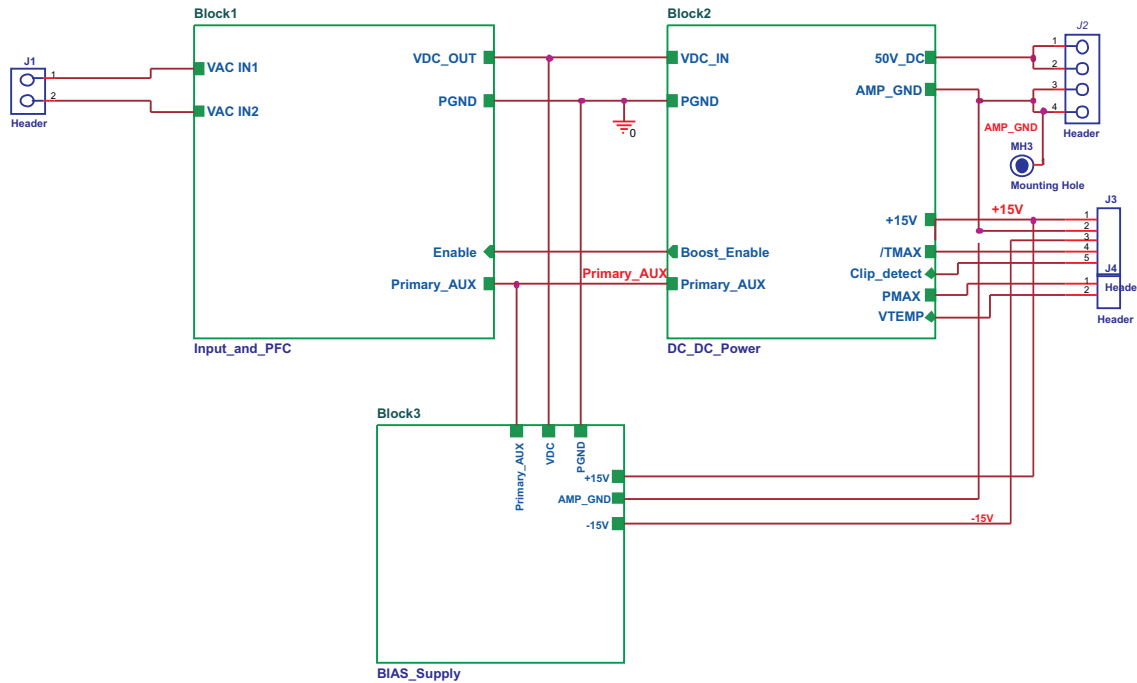

Figure 12. Connectors and Top Level

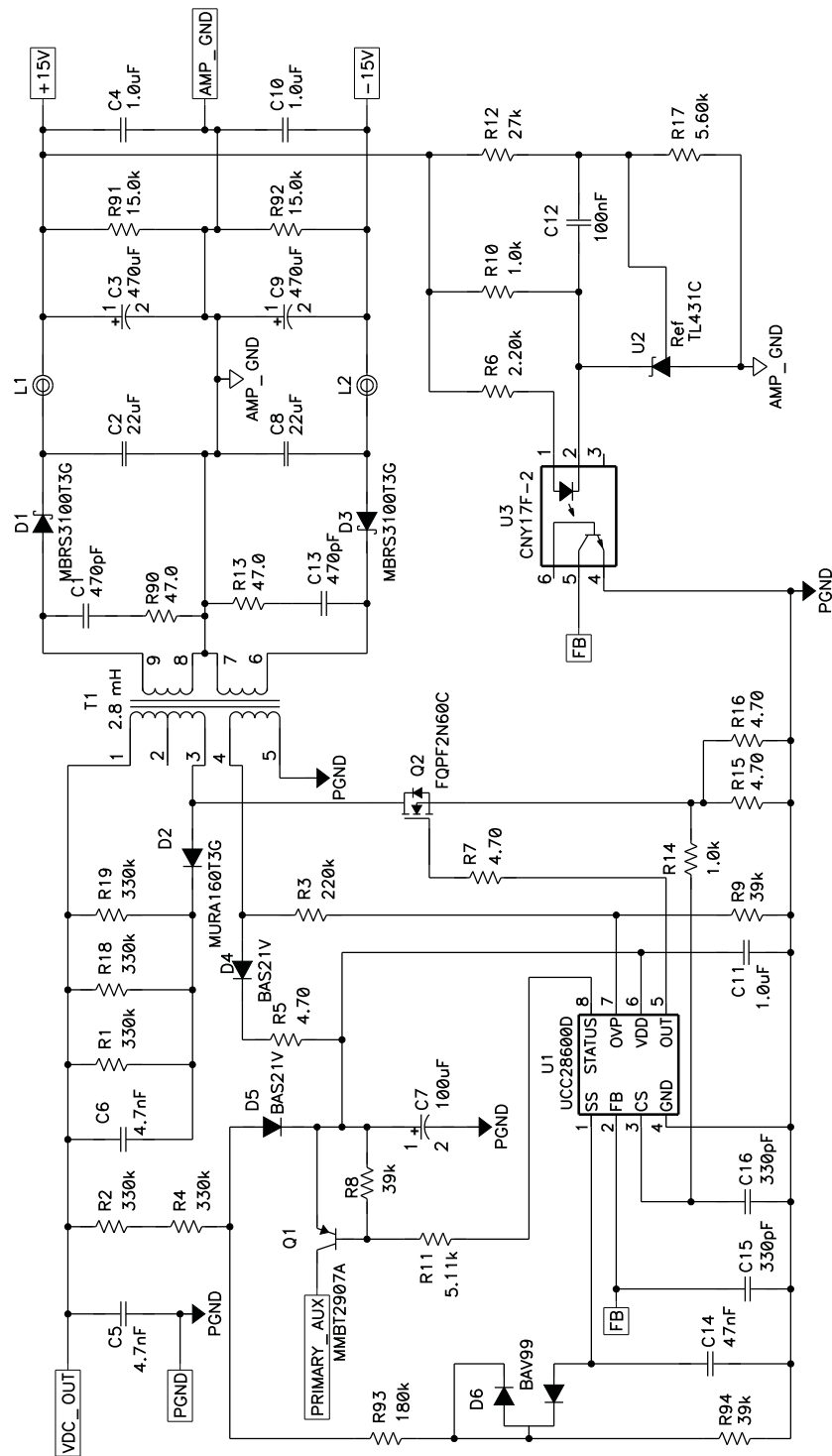
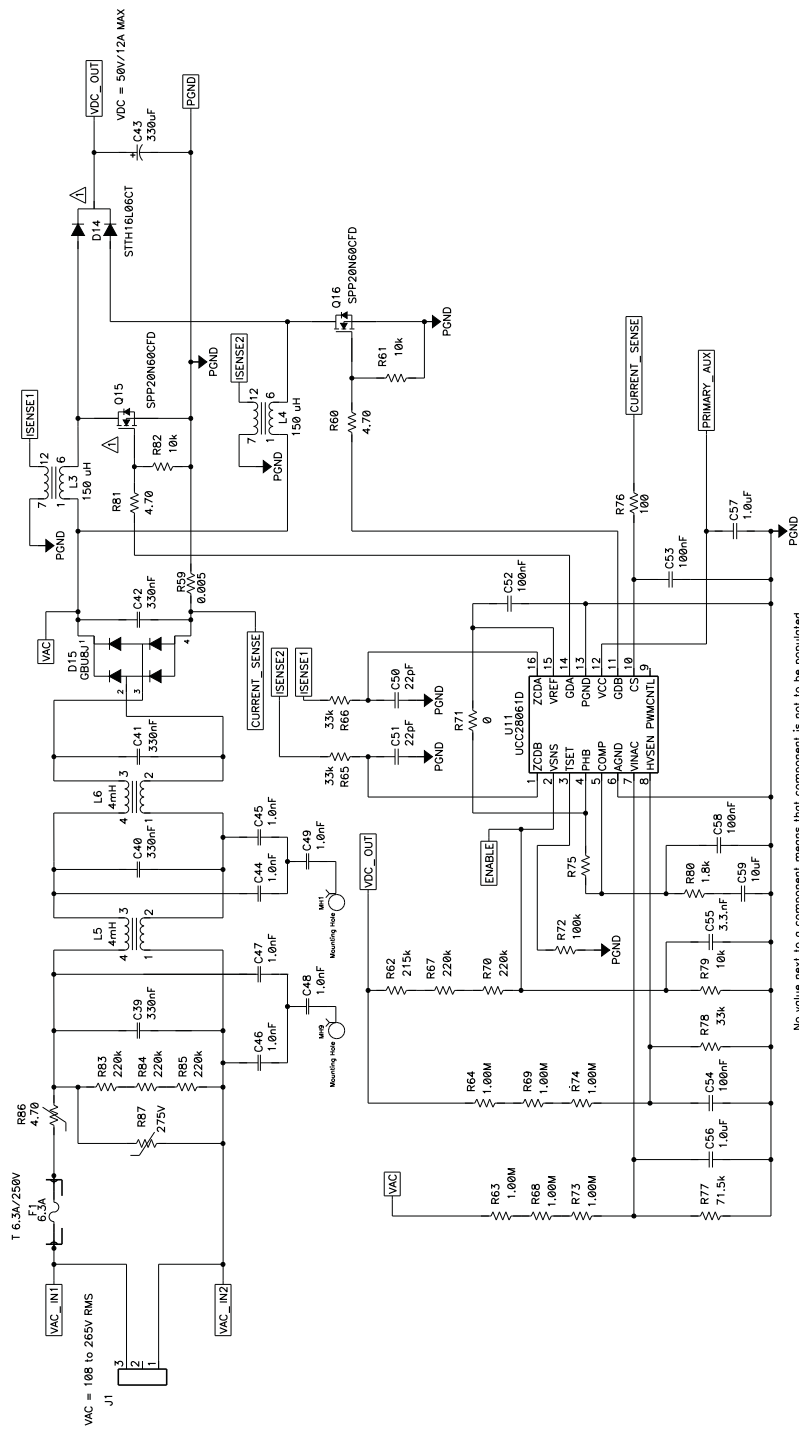

Figure 13. UCC28600 15V Bias Converter



No value next to a component means that component is not to be populated

Figure 14. UCC28061, PFC

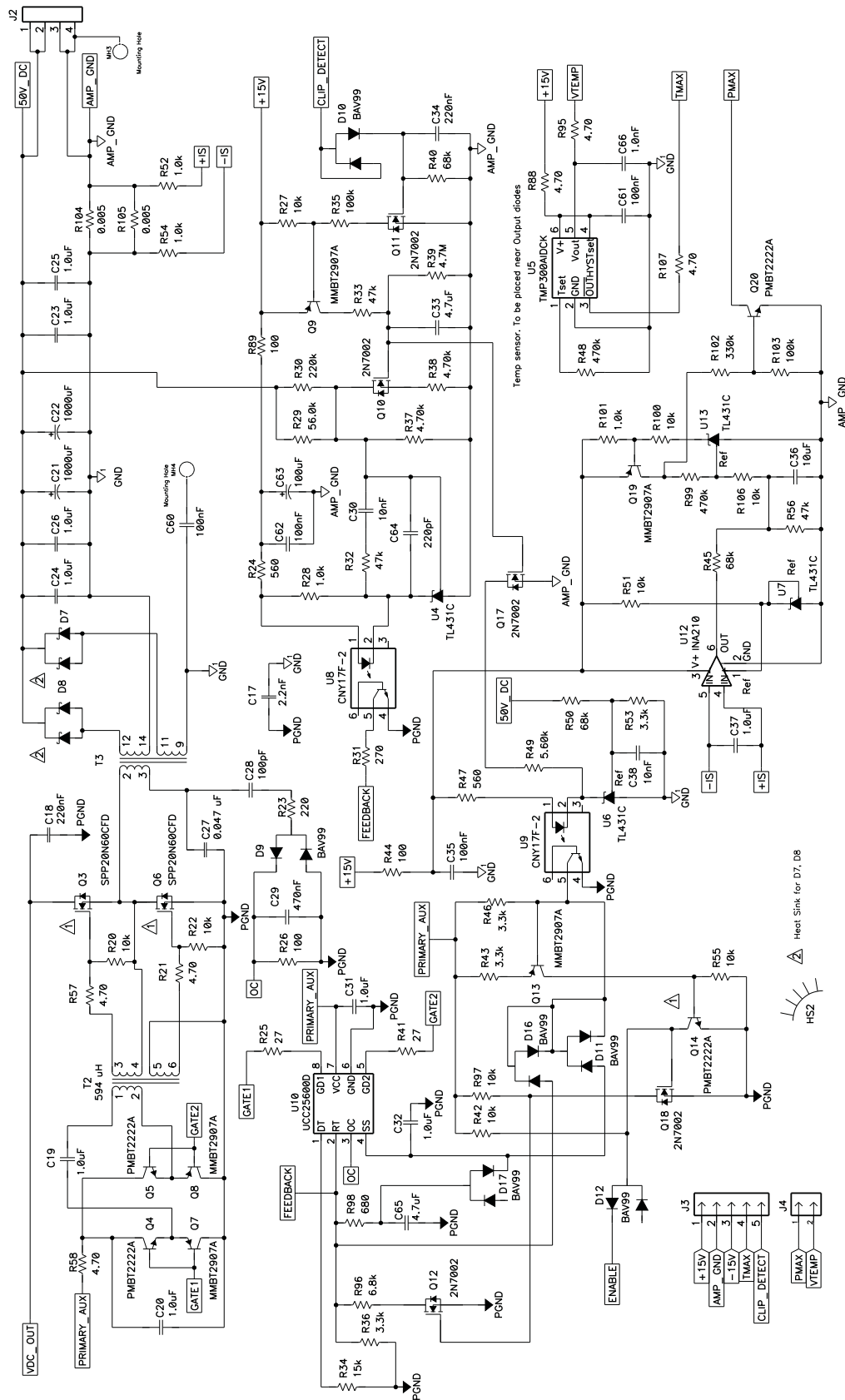

Figure 15. UCC25600, LLC DC/DC Converter

△ No value next to a component means that component is not to be populated

8 Parts List

Table 2. Bill of Materials

Qty	Part Reference	Description	Manufacture	First Mfr P/N
2	C1 C13	Ceramic 470pF / 50V / 10% NP0 0603 Capacitor	BC Components	0603N471K500NT
2	C2 C8	Ceramic 22µF / 16V / 20% X7R 1210 Capacitor	Taiyo Yuden	EMK325BJ226MM-T
2	C3 C9	Electrolytic 470µF / 25V / 20% Aluminium 3.5mm x 8mm FC Series - Low Impedance Capacitor	Panasonic	EEUFC1E471L
8	C4 C10 C19 C20 C31 C32 C37 C57	Ceramic 1µF / 16V / 20% X7R 0805 Capacitor	BC Components	0805B105M160NT
2	C5 C6	Ceramic 4.7nF / 500V / 10% X7R 1206 Capacitor	AVX	12067C472KAT2A
2	C7 C63	Electrolytic 100µF / 25V / 20% Aluminium 2.5mm x 6.3mm FC Series – Low Impedance Capacitor	Panasonic	EEUFC1E101S
2	C11 C56	Ceramic 1µF / 25V / 10% X5R 0805 Capacitor	Panasonic	ECJ-2FB1E105K
9	C12 C35 C52 C53 C54 C58 C60 C61 C62	Ceramic 100nF / 50V / 20% X7R 0603 Capacitor	Vishay	VJ0603Y104MXA
1	C14	Ceramic 47nF / 16V / 20% X7R 0603 Capacitor	BC Components	0603B473M160NT
2	C15 C16	Ceramic 330pF / 50V / 10% NP0 0603 Capacitor	BC Components	0603N101K500NT
1	C17	Ceramic 2.2nF / 250V / 20% Y5U 10mm (W:7mm L:9mm) Disc plate Capacitor	Murata	DE1E3KX222MA4BL01
1	C18	Metal Film 220nF / 630V / 20% Polyester 15mm (W:10mm L:18mm) Capacitor	Vishay	2222 373 63224
2	C21 C22	Electrolytic 1000µF / 63V / 20% Aluminium 7.5mm x 16mm FC Series – Low Impedance Capacitor	Panasonic	EEUFC1J102
4	C23 C24 C25 C26	Ceramic 1µF / 100V / 10% X7R 1210 Capacitor	Murata	GRM32ER72A105KA01L
1	C27	Metal Film 47nF / 1.2kV / 10% Polypropylene Capacitor	Vishay	715P473912MD3
1	C28	Ceramic 100pF / 500V / 5% COG 1206 Capacitor	AVX	12067A101JAT2A
1	C29	Ceramic 470nF / 16V / 20% X7R 0805 Capacitor	BC Components	0805B474M160NT
2	C30 C38	Ceramic 10nF / 100V / 20% X7R 0603 Capacitor	Vishay	VJ0603Y103MXB
2	C33 C65	Ceramic 4.7µF / 6.3V / 20% X5R 0603 Capacitor	Panasonic	ECJ-1V50J475M
1	C34	Ceramic 220nF / 16V / 20% X7R 0603 Capacitor	BC Components	VJ0603Y224MXJ
2	C36 C59	Ceramic 10µF / 6.3V / 10% X5R 0805 Capacitor	Kemet	C0805C106K9PAC
4	C39 C40 C41 C42	Metal Film 330nF / 275V / 20% Polypropylene 15mm (W:9mm L:18mm) Capacitor	Epcos	B32922A2334M
1	C43	Electrolytic 330µF / 450V / 20% Aluminium 10mm x 30mm 85° – Radial (Snap-In) Capacitor	Panasonic	ECOS2WP331DA
6	C44 C45 C46 C47 C48 C49	Ceramic 1nF / 250V / 20% Y5U 5mm (W:5.0mm L:7.2mm) Disc plate Capacitor	Murata	DE2E3KY102MA2BM01
2	C50 C51	Ceramic 22pF / 50V / 10% NP0 0603 Capacitor	BC Components	0603N220K500NT
1	C55	Ceramic 3.3nF / 50V / 10% NP0 0603 Capacitor	BC Components	0603N102K500NT
1	C64	Ceramic 220pF / 50V / 10% NP0 0603 Capacitor	BC Components	0603N221K500NT
1	C66	Ceramic 1nF / 100V / 10% X7R 0603 Capacitor	Murata	GRM188R72A102KA01
2	D1 D3	3A / 100V Schottky Schottky Barrier Rectifier MBR3100T3 Diode (SMC)	ON Semiconductor	MBRS3100T3
1	D2	1A / 600V Ultra Fast Recovery Ultrafast Power Rectifier MURA160T3 Diode (SMA)	ON Semiconductor	MURA160T3
2	D4 D5	250V Small Signal BAS21 Diode (SOP3-DBZ)	Vishay	BAS21-V-GS08
7	D6 D9 D10 D11 D12 D16 D17	250mA / 70V 350mW Small Signal Dual (A-C-CA) BAV99 Diode (SOP3-DBZ)	Vishay	BAV99-V-GS08
2	D7 D8	20A / 200V Schottky Switchmode Power Rectifier MBR20H200CT Diode (TO220FULLPAK)	Farnell	145-3404
1	D14	16A / 600V Ultra Fast Recovery Ultrafast High Voltage Rectifier VF=1.05V trr=35ns STTH16L06C Diode (TO220FULLPAK)	STMicro	STTH16L06CFP
1	D15	8A / 600V Bridge Diode (GBU)	Fairchild	GBU8J
1	F1	Fuse Holder PCB Vertical Mount Fuse Holder	Littelfuse	831
1	HEATSINK1	TIC-HSINK-064_2.00 / Heatsink for 5 x TO-220 package, length 75 mm		TIC-HSINK-064(2.00)

Table 2. Bill of Materials (continued)

Qty	Part Reference	Description	Manufacture	First Mfr P/N
1	HEATSINK2	TIC-HSINK-065_1.00 / Heatsink for 2 × TO-220 package, length 50 mm		TIC-HSINK-065(1.00)
1	J1	3 pins / 1 row / 5.1mm Pitch Vertical Male Pin header Header	On Shore Technology Inc.	ED120/3DS
1	J2	4 pins / 1 row / 3.96mm Pitch Vertical Male Pin header Header	JST	B4P-VH
1	J3	5 pins / 1 row / 2.54mm Pitch Vertical Male Friction lock Pin header Header	Molex	22-27-2051
1	J4	2 pins / 1 row / 2.54mm Pitch Vertical Male Friction lock Pin header Header	Molex	22-27-2021
2	L1 L2	Ferrite / 300mA 25% SMD Ferrite Bead, 120R Ferrite Bead Inductor (0805)	Tyco	BMB2A0120AN4
2	L3 L4	150µH 0.26R Boost Inductor with sense winding	Ole Wolff	OWTR-PQ26/20PC44-3708-NL
2	L5 L6	4mH / Choke Coil Ferrite Inductor	Ole Wolff	OWPFC2225BNP-402
6	Q1 Q7 Q8 Q9 Q13 Q19	800mA / 40V PNP Small signal MMBT2907A Transistor (SOT-23)	Fairchild	MMBT2907A
1	Q2	2A / 600V N-ch Power 4.7R FQPF2N60C MOSFET (TO220FULLPAK)	Fairchild	FQPF2N60C
4	Q3 Q6 Q15 Q16	20A / 500V N-ch Power 0.26R FDPF20N50FT MOSFET (TO220FULLPAK)	Fairchild	FDPF20N50FT
4	Q4 Q5 Q14 Q20	600mA / 40V NPN Small signal PMBT2222 Transistor (SOT-23)	Philips	PMBT2222
5	Q10 Q11 Q12 Q17 Q18	0.115A / 60V N-ch Power 2N7002 MOSFET (SOT-23)	Fairchild	2N7002
5	R1 R2 R4 R18 R19	330k / 250mW / 1% / 1206 Thick Film Resistor	Yageo	RC1206FR-07330KL
2	R3 R30	220k / 100mW / 5% / 0603 Thick Film Resistor	Yageo	RC0603JR-07220KL
12	R5 R7 R15 R16 R21 R57 R58 R60 R81 R88 R95 R107	4.70R / 125mW / 1% / 0805 Thick Film Resistor	Yageo	RC0805FR-074R7L
1	R6	2.20k / 100mW / 1% / 0603 Resistor	Yageo	RC0603FR-072K2L
3	R8 R9 R94	39k / 100mW / 5% / 0603 Resistor	Yageo	RC0603JR-0739KL
6	R10 R14 R28 R52 R54 R101	1.0k / 100mW / 5% / 0603 Resistor	Yageo	RC0603JR-071KL
12	R20 R22 R27 R42 R51 R55 R61 R79 R82 R97 R100 R106	10k / 100mW / 5% / 0603 Resistor	Yageo	RC0603JR-0710KL
1	R11	Resistor, 5.11 kΩ, 100 mW, 5%, 0603	STD	STD
1	R12	27k / 100mW / 5% / 0603 Resistor	Yageo	RC0603JR-0727KL
2	R13 R90	47.0R / 250mW / 1% / 1206 Resistor	Yageo	RC1206FR-0747RL
1	R17	5.60k / 100mW / 1% / 0603 Resistor	Yageo	RC0603FR-075K6L
1	R23	220R / 250mW / 1% / 1206 Resistor	Yageo	RC1206FR-07220RL
2	R24 R47	560R / 100mW / 5% / 0603 Resistor	Yageo	RC0603JR-07560RL
2	R25 R41	27R / 100mW / 5% / 0603 Resistor	Yageo	RC0603JR-0727RL
4	R26 R44 R76 R89	100R / 100mW / 5% / 0603 Resistor	Yageo	RC0603JR-07100RL
1	R29	56.0k / 125mW / 1% / 0805 Resistor	Yageo	RC0805FR-0756KL
1	R31	270R / 100mW / 5% / 0603 Resistor	Yageo	RC0603JR-07270RL
3	R32 R33 R56	47k / 100mW / 5% / 0603 Resistor	Yageo	RC0603JR-0747KL
1	R34	15k / 100mW / 5% / 0603 Resistor	Yageo	RC0603JR-0715KL
4	R35 R72 R75 R103	100k / 100mW / 5% / 0603 Resistor	Yageo	RC0603JR-07100KL
4	R36 R43 R46 R53	3.3k / 100mW / 5% / 0603 Resistor	Yageo	RC0603JR-073K3L
2	R37 R38	4.70k / 100mW / 1% / 0603 Resistor	Yageo	RC0603FR-074K7L
1	R39	4.7M / 100mW / 5% / 0603 Resistor	Yageo	RC0603JR-074M7L
3	R40 R45 R50	68k / 100mW / 5% / 0603 Resistor	Yageo	RC0603JR-0768KL

Table 2. Bill of Materials (continued)

Qty	Part Reference	Description	Manufacture	First Mfr P/N
2	R48 R99	470k / 100mW / 5% / 0603 Resistor	Yageo	RC0603JR-07470KL
1	R49	5.6k / 100mW / 5% / 0603 Resistor	Yageo	RC0603JR-075K6L
3	R59 R104 R105	5mR / 1W / 5% / 2010 Resistor	Welwyn	LRF2010-R005JW
1	R62	215k / 125mW / 1% / 0805 Resistor	Yageo	RC0805FR-07200KL
6	R63 R64 R68 R69 R73 R74	1.00M / 125mW / 1% / 0805 Resistor	Yageo	RC0805FR-071ML
3	R65 R66 R78	33k / 100mW / 5% / 0603 Resistor	Yageo	RC0603JR-0733KL
5	R67 R70 R83 R84 R85	220k / 125mW / 1% / 0805 Resistor	Yageo	RC0805FR-07220KL
1	R71	0k / 125mW / 1% / 0805 Resistor	Yageo	RC0805FR-07820KL
0	R75	Resistor, not populated, 100 mW, 5%, 0603	std	std
1	R77	Resistor, 71.5 kΩ, 100 mW, 5%, 0603	std	std
1	R80	1.8k / 100mW / 5% / 0603 Resistor	Yageo	RC0603JR-071K8L
1	R86	4R7 / 3.1W / 20% / 7.5mm (W:7mm L:15mm) Inrush Current Limiter NTC Resistor	Epcos	B57237S0479M000
1	R87	8000A / 230V 130J (2ms) Transient Voltage Suppressor 230V Zener (SIOV-S20K230)	Epcos	B72220S0231K101
2	R91 R92	15.0k / 125mW / 1% / 0805 Resistor	Yageo	RC0805FR-0715KL
1	R93	180k / 100mW / 5% / 0603 Resistor	Yageo	RC0603JR-07180KL
1	R96	6.8k / 100mW / 5% / 0603 Resistor	Yageo	RC0603JR-076K8L
1	R98	680R / 100mW / 5% / 0603 Resistor	Yageo	RC0603JR-07680RL
1	R102	330k / 100mW / 5% / 0603 Resistor	Yageo	RC0603JR-07330KL
1	TR1	Flyback Transformer	Ole Wolff	OWTR-E20/10/6-3708-NL Rev01
1	TR2	Gatedrive Transformer	Ole Wolff	OWTR-TX13/7.9/6.4-3708-NL Rev01
1	TR3	LLC Transformer	Ole Wolff	OWTR-ETD39P3903-3708-NL Rev 02
1	U10	UCC25600 / 8-Pin High Performance Resonant Mode Controller (SOIC8-D)	Texas Instruments	UCC25600D
1	U11	UCC28061 / Natural Interleaving Transition-Mode PFC Controller, Low noise (SOIC16-D)	Texas Instruments	UCC28061D
1	U12	INA210 / Voltage Output, HS or LS Measurement, CURRENT SHUNT REGULATOR (DCK6)	Texas Instruments	INA210AIDCKT
5	U13 U2 U4 U6 U7	TL431C / Adjustable Precision Shunt Regulator (SOT23-3)	Texas Instruments	TL431CDBZR
1	U1	UCC28600 / 8-Pin Quasi-Resonant Flyback Green-Mode Controller (SOIC8-D)	Texas Instruments	UCC28600D
3	U3 U8 U9	Optocoupler CTR 63 to 125% CNY17-2 Optocoupler (SMD-6)	Vishay	CNY17F-2X009
1	U5	TMP300 / 1.8V, Resistor-Programmable Temperature Switch and Analog Out Temp Sensor (DCK6)	Texas Instruments	TMP300AIDCKR

8.1 Magnetics Supplier

<http://www.owolff.com>

OWPFC2225BNP-402

OWTR-PQ2620PC44-3708-NL

OWTR-E20/10/6-3708-NL Rev01

OWTR-TX13/7.9/6.4-3708-NL Rev01

OWTR-ETD39P3903-3708-NL Rev 02

8.2 Heat-Sink Drawings

8.2.1 HEATSINK1

The heat sink is based on a ready-made extrusion, type MQ75-1 from Aavid Thermalloy available from Farnell no.: 232970 or KS29.2 from Austerlitz electronic available from ELFA no.: 75-624-81

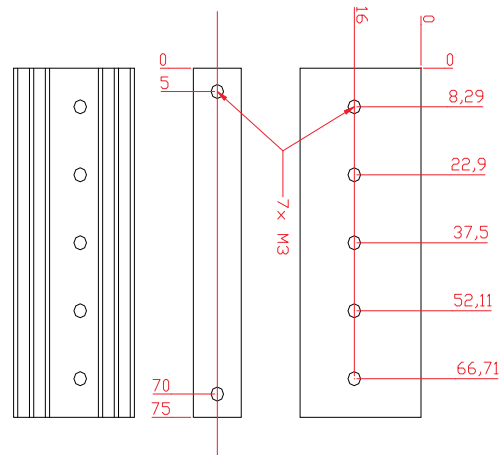
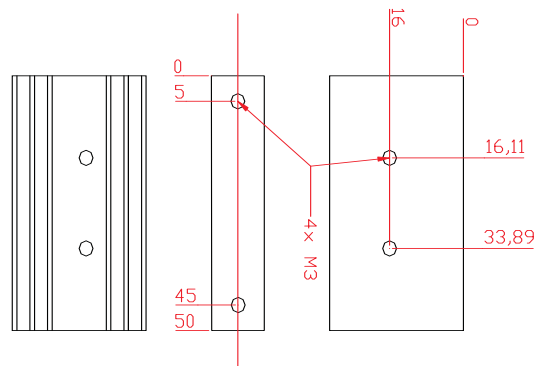

Figure 16. FET Heat-sink

8.2.2 HEATSINK2

The diode heat sink is based on the same ready-made extrusion, but is 50mm-long, type MQ50-1 from Aavid Thermalloy available from Farnell no.: 232968 or KS29.2-50E from Austerlitz electronic available from ELFA no.: 75-623-41



9 PCB Layout

The PCB layout is made on a 1.6mm double sided 70µm Cu FR4 PCB, 110x144mm Gerber files are available as download in the tools folder, or contact the nearest TI representative.

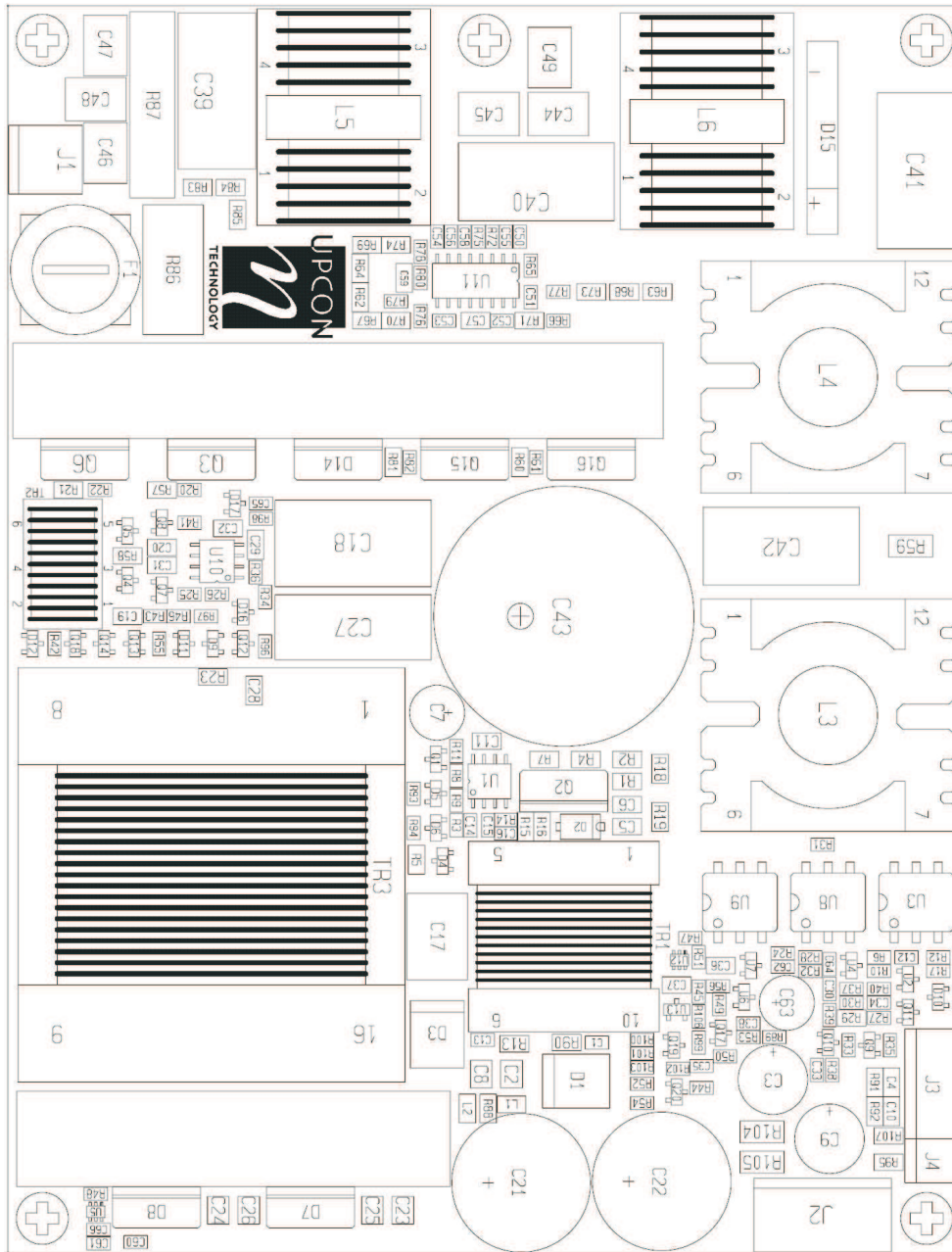

Figure 17. Component Placement

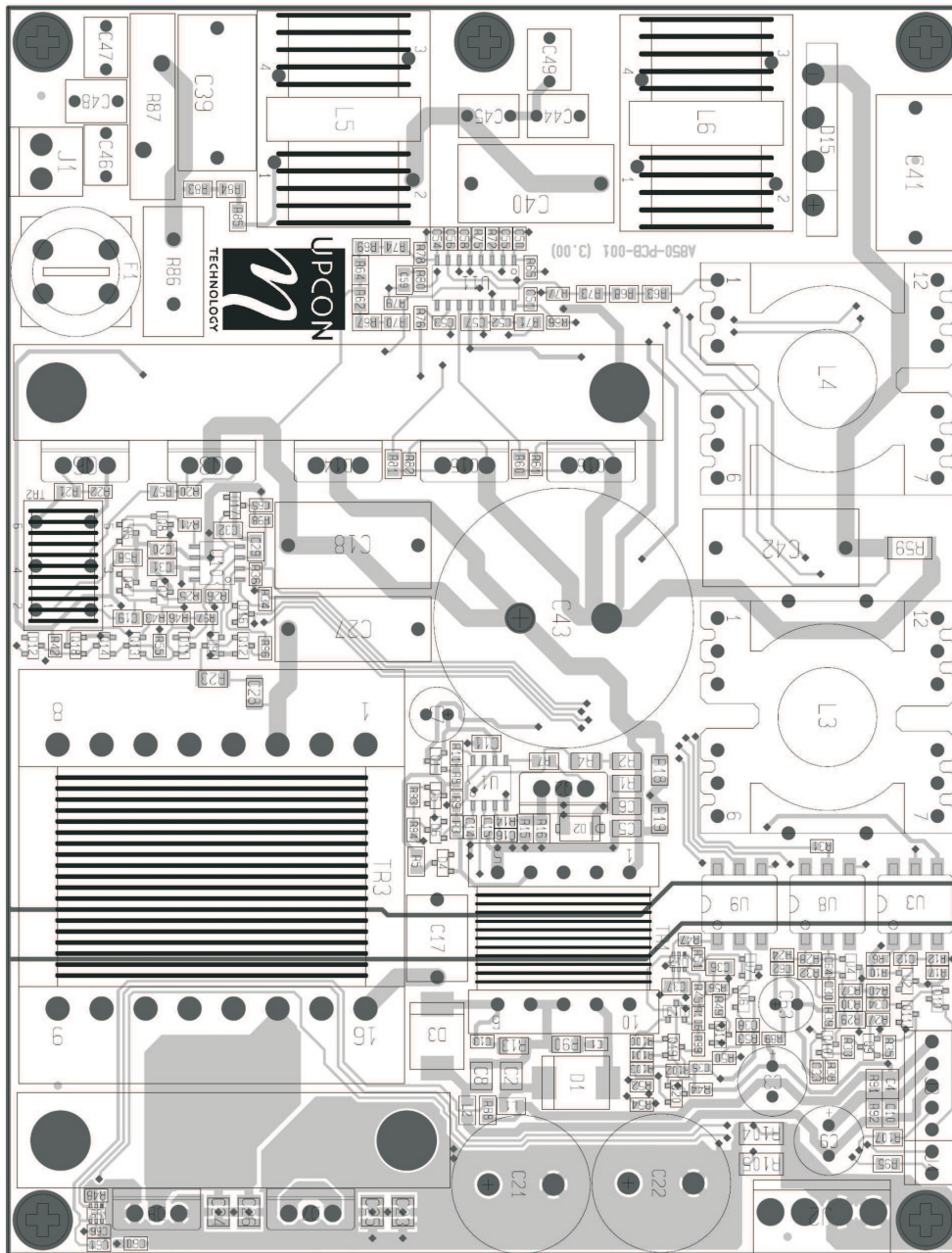

Figure 18. Top Multilayer

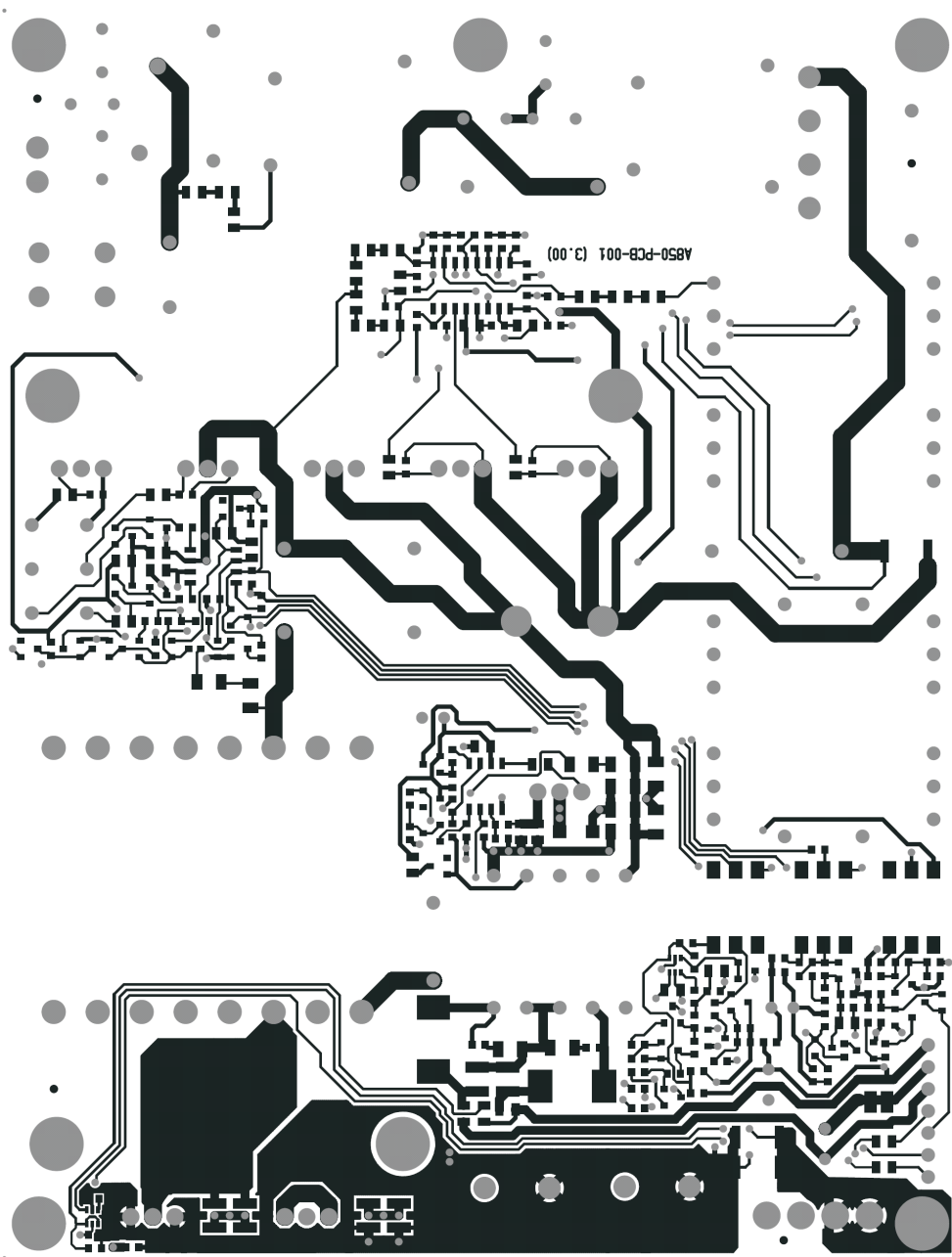

Figure 19. Top Layer

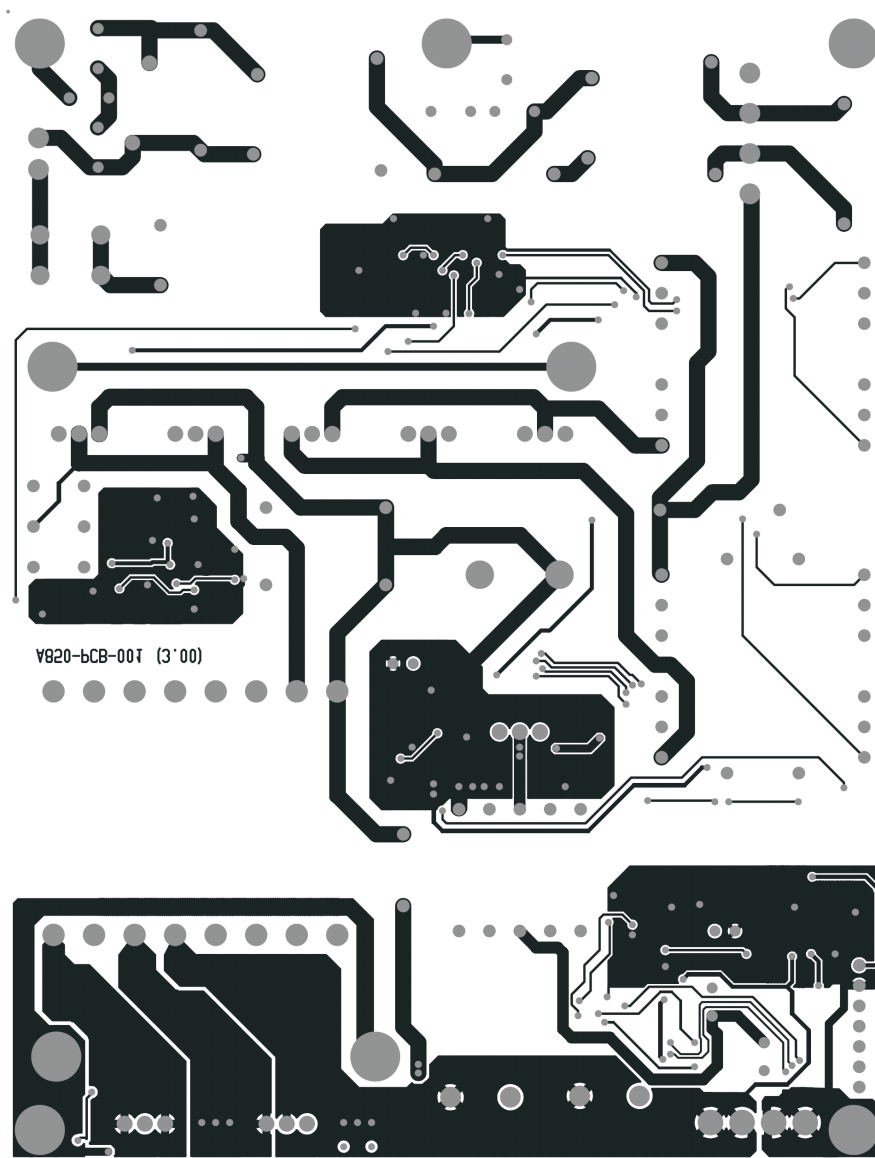

Figure 20. Bottom Layer

10 References

1. *UCC28061 Data sheet*, ([SLUS837](#))
2. *UCC28061EVM 300W Interleaved PFC Pre-Regulator User's Guide*, ([SLUU316](#))
3. *PR883: A 300-W, Universal Input, Isolated PFC Power Supply for LCD TV Applications*, ([SLUU341](#))
4. *UCC25600 Data sheet*, ([SLUS846](#))
5. Bing Lu, Wenduo Liu, Yan Liang, Fred C. Lee, and Jacobus D. van Wyk, *Optimal Design Methodology for LLC Resonant Converter*, IEEE APEC 2006
6. *TAS5630 Datasheet* ([SLES220A](#))

This design is done by an external design house; Upcon Technology. Contact information can be found at: <http://www.upcontechnology.com/>

EVALUATION BOARD/KIT/MODULE (EVM) ADDITIONAL TERMS

Texas Instruments (TI) provides the enclosed Evaluation Board/Kit/Module (EVM) under the following conditions:

The user assumes all responsibility and liability for proper and safe handling of the goods. Further, the user indemnifies TI from all claims arising from the handling or use of the goods.

Should this evaluation board/kit not meet the specifications indicated in the User's Guide, the board/kit may be returned within 30 days from the date of delivery for a full refund. THE FOREGOING LIMITED WARRANTY IS THE EXCLUSIVE WARRANTY MADE BY SELLER TO BUYER AND IS IN LIEU OF ALL OTHER WARRANTIES, EXPRESSED, IMPLIED, OR STATUTORY, INCLUDING ANY WARRANTY OF MERCHANTABILITY OR FITNESS FOR ANY PARTICULAR PURPOSE. EXCEPT TO THE EXTENT OF THE INDEMNITY SET FORTH ABOVE, NEITHER PARTY SHALL BE LIABLE TO THE OTHER FOR ANY INDIRECT, SPECIAL, INCIDENTAL, OR CONSEQUENTIAL DAMAGES.

Please read the User's Guide and, specifically, the Warnings and Restrictions notice in the User's Guide prior to handling the product. This notice contains important safety information about temperatures and voltages. For additional information on TI's environmental and/or safety programs, please visit www.ti.com/esh or contact TI.

No license is granted under any patent right or other intellectual property right of TI covering or relating to any machine, process, or combination in which such TI products or services might be or are used. TI currently deals with a variety of customers for products, and therefore our arrangement with the user is not exclusive. TI assumes no liability for applications assistance, customer product design, software performance, or infringement of patents or services described herein.

REGULATORY COMPLIANCE INFORMATION

As noted in the EVM User's Guide and/or EVM itself, this EVM and/or accompanying hardware may or may not be subject to the Federal Communications Commission (FCC) and Industry Canada (IC) rules.

For EVMs **not** subject to the above rules, this evaluation board/kit/module is intended for use for ENGINEERING DEVELOPMENT, DEMONSTRATION OR EVALUATION PURPOSES ONLY and is not considered by TI to be a finished end product fit for general consumer use. It generates, uses, and can radiate radio frequency energy and has not been tested for compliance with the limits of computing devices pursuant to part 15 of FCC or ICES-003 rules, which are designed to provide reasonable protection against radio frequency interference. Operation of the equipment may cause interference with radio communications, in which case the user at his own expense will be required to take whatever measures may be required to correct this interference.

General Statement for EVMs including a radio

User Power/Frequency Use Obligations: This radio is intended for development/professional use only in legally allocated frequency and power limits. Any use of radio frequencies and/or power availability of this EVM and its development application(s) must comply with local laws governing radio spectrum allocation and power limits for this evaluation module. It is the user's sole responsibility to only operate this radio in legally acceptable frequency space and within legally mandated power limitations. Any exceptions to this are strictly prohibited and unauthorized by Texas Instruments unless user has obtained appropriate experimental/development licenses from local regulatory authorities, which is responsibility of user including its acceptable authorization.

For EVMs annotated as FCC – FEDERAL COMMUNICATIONS COMMISSION Part 15 Compliant

Caution

This device complies with part 15 of the FCC Rules. Operation is subject to the following two conditions: (1) This device may not cause harmful interference, and (2) this device must accept any interference received, including interference that may cause undesired operation.

Changes or modifications not expressly approved by the party responsible for compliance could void the user's authority to operate the equipment.

FCC Interference Statement for Class A EVM devices

This equipment has been tested and found to comply with the limits for a Class A digital device, pursuant to part 15 of the FCC Rules. These limits are designed to provide reasonable protection against harmful interference when the equipment is operated in a commercial environment. This equipment generates, uses, and can radiate radio frequency energy and, if not installed and used in accordance with the instruction manual, may cause harmful interference to radio communications. Operation of this equipment in a residential area is likely to cause harmful interference in which case the user will be required to correct the interference at his own expense.

FCC Interference Statement for Class B EVM devices

This equipment has been tested and found to comply with the limits for a Class B digital device, pursuant to part 15 of the FCC Rules. These limits are designed to provide reasonable protection against harmful interference in a residential installation. This equipment generates, uses and can radiate radio frequency energy and, if not installed and used in accordance with the instructions, may cause harmful interference to radio communications. However, there is no guarantee that interference will not occur in a particular installation. If this equipment does cause harmful interference to radio or television reception, which can be determined by turning the equipment off and on, the user is encouraged to try to correct the interference by one or more of the following measures:

- Reorient or relocate the receiving antenna.
- Increase the separation between the equipment and receiver.
- Connect the equipment into an outlet on a circuit different from that to which the receiver is connected.
- Consult the dealer or an experienced radio/TV technician for help.

For EVMs annotated as IC – INDUSTRY CANADA Compliant

This Class A or B digital apparatus complies with Canadian ICES-003.

Changes or modifications not expressly approved by the party responsible for compliance could void the user's authority to operate the equipment.

Concerning EVMs including radio transmitters

This device complies with Industry Canada licence-exempt RSS standard(s). Operation is subject to the following two conditions: (1) this device may not cause interference, and (2) this device must accept any interference, including interference that may cause undesired operation of the device.

Concerning EVMs including detachable antennas

Under Industry Canada regulations, this radio transmitter may only operate using an antenna of a type and maximum (or lesser) gain approved for the transmitter by Industry Canada. To reduce potential radio interference to other users, the antenna type and its gain should be so chosen that the equivalent isotropically radiated power (e.i.r.p.) is not more than that necessary for successful communication.

This radio transmitter has been approved by Industry Canada to operate with the antenna types listed in the user guide with the maximum permissible gain and required antenna impedance for each antenna type indicated. Antenna types not included in this list, having a gain greater than the maximum gain indicated for that type, are strictly prohibited for use with this device.

Cet appareil numérique de la classe A ou B est conforme à la norme NMB-003 du Canada.

Les changements ou les modifications pas expressément approuvés par la partie responsable de la conformité ont pu vider l'autorité de l'utilisateur pour actionner l'équipement.

Concernant les EVMs avec appareils radio

Le présent appareil est conforme aux CNR d'Industrie Canada applicables aux appareils radio exempts de licence. L'exploitation est autorisée aux deux conditions suivantes : (1) l'appareil ne doit pas produire de brouillage, et (2) l'utilisateur de l'appareil doit accepter tout brouillage radioélectrique subi, même si le brouillage est susceptible d'en compromettre le fonctionnement.

Concernant les EVMs avec antennes détachables

Conformément à la réglementation d'Industrie Canada, le présent émetteur radio peut fonctionner avec une antenne d'un type et d'un gain maximal (ou inférieur) approuvé pour l'émetteur par Industrie Canada. Dans le but de réduire les risques de brouillage radioélectrique à l'intention des autres utilisateurs, il faut choisir le type d'antenne et son gain de sorte que la puissance isotrope rayonnée équivalente (p.i.r.e.) ne dépasse pas l'intensité nécessaire à l'établissement d'une communication satisfaisante.

Le présent émetteur radio a été approuvé par Industrie Canada pour fonctionner avec les types d'antenne énumérés dans le manuel d'usage et ayant un gain admissible maximal et l'impédance requise pour chaque type d'antenne. Les types d'antenne non inclus dans cette liste, ou dont le gain est supérieur au gain maximal indiqué, sont strictement interdits pour l'exploitation de l'émetteur.

【Important Notice for Users of this Product in Japan】

This development kit is NOT certified as Confirming to Technical Regulations of Radio Law of Japan

If you use this product in Japan, you are required by Radio Law of Japan to follow the instructions below with respect to this product:

1. Use this product in a shielded room or any other test facility as defined in the notification #173 issued by Ministry of Internal Affairs and Communications on March 28, 2006, based on Sub-section 1.1 of Article 6 of the Ministry's Rule for Enforcement of Radio Law of Japan,
2. Use this product only after you obtained the license of Test Radio Station as provided in Radio Law of Japan with respect to this product, or
3. Use of this product only after you obtained the Technical Regulations Conformity Certification as provided in Radio Law of Japan with respect to this product. Also, please do not transfer this product, unless you give the same notice above to the transferee. Please note that if you could not follow the instructions above, you will be subject to penalties of Radio Law of Japan.

Texas Instruments Japan Limited
(address) 24-1, Nishi-Shinjuku 6 chome, Shinjuku-ku, Tokyo, Japan

<http://www.tij.co.jp>

【ご使用にあたっての注】

本開発キットは技術基準適合証明を受けておりません。

本製品のご使用に際しては、電波法遵守のため、以下のいずれかの措置を取っていただく必要がありますのでご注意ください。

1. 電波法施行規則第6条第1項第1号に基づく平成18年3月28日総務省告示第173号で定められた電波暗室等の試験設備でご使用いただく。
2. 実験局の免許を取得後ご使用いただく。
3. 技術基準適合証明を取得後ご使用いただく。

なお、本製品は、上記の「ご使用にあたっての注意」を譲渡先、移転先に通知しない限り、譲渡、移転できないものとします。

上記を遵守頂けない場合は、電波法の罰則が適用される可能性があることをご留意ください。

日本テキサス・インスツルメンツ株式会社
東京都新宿区西新宿6丁目24番1号
西新宿三井ビル

<http://www.tij.co.jp>

EVALUATION BOARD/KIT/MODULE (EVM) WARNINGS, RESTRICTIONS AND DISCLAIMERS

For Feasibility Evaluation Only, in Laboratory/Development Environments. Unless otherwise indicated, this EVM is not a finished electrical equipment and not intended for consumer use. It is intended solely for use for preliminary feasibility evaluation in laboratory/development environments by technically qualified electronics experts who are familiar with the dangers and application risks associated with handling electrical mechanical components, systems and subsystems. It should not be used as all or part of a finished end product.

Your Sole Responsibility and Risk. You acknowledge, represent and agree that:

1. You have unique knowledge concerning Federal, State and local regulatory requirements (including but not limited to Food and Drug Administration regulations, if applicable) which relate to your products and which relate to your use (and/or that of your employees, affiliates, contractors or designees) of the EVM for evaluation, testing and other purposes.
2. You have full and exclusive responsibility to assure the safety and compliance of your products with all such laws and other applicable regulatory requirements, and also to assure the safety of any activities to be conducted by you and/or your employees, affiliates, contractors or designees, using the EVM. Further, you are responsible to assure that any interfaces (electronic and/or mechanical) between the EVM and any human body are designed with suitable isolation and means to safely limit accessible leakage currents to minimize the risk of electrical shock hazard.
3. You will employ reasonable safeguards to ensure that your use of the EVM will not result in any property damage, injury or death, even if the EVM should fail to perform as described or expected.
4. You will take care of proper disposal and recycling of the EVM's electronic components and packing materials.

Certain Instructions. It is important to operate this EVM within TI's recommended specifications and environmental considerations per the user guidelines. Exceeding the specified EVM ratings (including but not limited to input and output voltage, current, power, and environmental ranges) may cause property damage, personal injury or death. If there are questions concerning these ratings please contact a TI field representative prior to connecting interface electronics including input power and intended loads. Any loads applied outside of the specified output range may result in unintended and/or inaccurate operation and/or possible permanent damage to the EVM and/or interface electronics. Please consult the EVM User's Guide prior to connecting any load to the EVM output. If there is uncertainty as to the load specification, please contact a TI field representative. During normal operation, some circuit components may have case temperatures greater than 60°C as long as the input and output are maintained at a normal ambient operating temperature. These components include but are not limited to linear regulators, switching transistors, pass transistors, and current sense resistors which can be identified using the EVM schematic located in the EVM User's Guide. When placing measurement probes near these devices during normal operation, please be aware that these devices may be very warm to the touch. As with all electronic evaluation tools, only qualified personnel knowledgeable in electronic measurement and diagnostics normally found in development environments should use these EVMs.

Agreement to Defend, Indemnify and Hold Harmless. You agree to defend, indemnify and hold TI, its licensors and their representatives harmless from and against any and all claims, damages, losses, expenses, costs and liabilities (collectively, "Claims") arising out of or in connection with any use of the EVM that is not in accordance with the terms of the agreement. This obligation shall apply whether Claims arise under law of tort or contract or any other legal theory, and even if the EVM fails to perform as described or expected.

Safety-Critical or Life-Critical Applications. If you intend to evaluate the components for possible use in safety critical applications (such as life support) where a failure of the TI product would reasonably be expected to cause severe personal injury or death, such as devices which are classified as FDA Class III or similar classification, then you must specifically notify TI of such intent and enter into a separate Assurance and Indemnity Agreement.

Mailing Address: Texas Instruments, Post Office Box 655303, Dallas, Texas 75265
Copyright © 2012, Texas Instruments Incorporated

STANDARD TERMS AND CONDITIONS FOR EVALUATION MODULES

1. *Delivery:* TI delivers TI evaluation boards, kits, or modules, including any accompanying demonstration software, components, or documentation (collectively, an "EVM" or "EVMs") to the User ("User") in accordance with the terms and conditions set forth herein. Acceptance of the EVM is expressly subject to the following terms and conditions.
 - 1.1 EVMs are intended solely for product or software developers for use in a research and development setting to facilitate feasibility evaluation, experimentation, or scientific analysis of TI semiconductors products. EVMs have no direct function and are not finished products. EVMs shall not be directly or indirectly assembled as a part or subassembly in any finished product. For clarification, any software or software tools provided with the EVM ("Software") shall not be subject to the terms and conditions set forth herein but rather shall be subject to the applicable terms and conditions that accompany such Software
 - 1.2 EVMs are not intended for consumer or household use. EVMs may not be sold, sublicensed, leased, rented, loaned, assigned, or otherwise distributed for commercial purposes by Users, in whole or in part, or used in any finished product or production system.
2. *Limited Warranty and Related Remedies/Disclaimers:*
 - 2.1 These terms and conditions do not apply to Software. The warranty, if any, for Software is covered in the applicable Software License Agreement.
 - 2.2 TI warrants that the TI EVM will conform to TI's published specifications for ninety (90) days after the date TI delivers such EVM to User. Notwithstanding the foregoing, TI shall not be liable for any defects that are caused by neglect, misuse or mistreatment by an entity other than TI, including improper installation or testing, or for any EVMs that have been altered or modified in any way by an entity other than TI. Moreover, TI shall not be liable for any defects that result from User's design, specifications or instructions for such EVMs. Testing and other quality control techniques are used to the extent TI deems necessary or as mandated by government requirements. TI does not test all parameters of each EVM.
 - 2.3 If any EVM fails to conform to the warranty set forth above, TI's sole liability shall be at its option to repair or replace such EVM, or credit User's account for such EVM. TI's liability under this warranty shall be limited to EVMs that are returned during the warranty period to the address designated by TI and that are determined by TI not to conform to such warranty. If TI elects to repair or replace such EVM, TI shall have a reasonable time to repair such EVM or provide replacements. Repaired EVMs shall be warranted for the remainder of the original warranty period. Replaced EVMs shall be warranted for a new full ninety (90) day warranty period.
3. *Regulatory Notices:*
 - 3.1 *United States*
 - 3.1.1 *Notice applicable to EVMs not FCC-Approved:*

This kit is designed to allow product developers to evaluate electronic components, circuitry, or software associated with the kit to determine whether to incorporate such items in a finished product and software developers to write software applications for use with the end product. This kit is not a finished product and when assembled may not be resold or otherwise marketed unless all required FCC equipment authorizations are first obtained. Operation is subject to the condition that this product not cause harmful interference to licensed radio stations and that this product accept harmful interference. Unless the assembled kit is designed to operate under part 15, part 18 or part 95 of this chapter, the operator of the kit must operate under the authority of an FCC license holder or must secure an experimental authorization under part 5 of this chapter.
 - 3.1.2 *For EVMs annotated as FCC – FEDERAL COMMUNICATIONS COMMISSION Part 15 Compliant:*

CAUTION

This device complies with part 15 of the FCC Rules. Operation is subject to the following two conditions: (1) This device may not cause harmful interference, and (2) this device must accept any interference received, including interference that may cause undesired operation.

Changes or modifications not expressly approved by the party responsible for compliance could void the user's authority to operate the equipment.

FCC Interference Statement for Class A EVM devices

NOTE: This equipment has been tested and found to comply with the limits for a Class A digital device, pursuant to part 15 of the FCC Rules. These limits are designed to provide reasonable protection against harmful interference when the equipment is operated in a commercial environment. This equipment generates, uses, and can radiate radio frequency energy and, if not installed and used in accordance with the instruction manual, may cause harmful interference to radio communications. Operation of this equipment in a residential area is likely to cause harmful interference in which case the user will be required to correct the interference at his own expense.

FCC Interference Statement for Class B EVM devices

NOTE: This equipment has been tested and found to comply with the limits for a Class B digital device, pursuant to part 15 of the FCC Rules. These limits are designed to provide reasonable protection against harmful interference in a residential installation. This equipment generates, uses and can radiate radio frequency energy and, if not installed and used in accordance with the instructions, may cause harmful interference to radio communications. However, there is no guarantee that interference will not occur in a particular installation. If this equipment does cause harmful interference to radio or television reception, which can be determined by turning the equipment off and on, the user is encouraged to try to correct the interference by one or more of the following measures:

- Reorient or relocate the receiving antenna.
- Increase the separation between the equipment and receiver.
- Connect the equipment into an outlet on a circuit different from that to which the receiver is connected.
- Consult the dealer or an experienced radio/TV technician for help.

3.2 Canada

3.2.1 For EVMs issued with an Industry Canada Certificate of Conformance to RSS-210

Concerning EVMs Including Radio Transmitters:

This device complies with Industry Canada license-exempt RSS standard(s). Operation is subject to the following two conditions: (1) this device may not cause interference, and (2) this device must accept any interference, including interference that may cause undesired operation of the device.

Concernant les EVMs avec appareils radio:

Le présent appareil est conforme aux CNR d'Industrie Canada applicables aux appareils radio exempts de licence. L'exploitation est autorisée aux deux conditions suivantes: (1) l'appareil ne doit pas produire de brouillage, et (2) l'utilisateur de l'appareil doit accepter tout brouillage radioélectrique subi, même si le brouillage est susceptible d'en compromettre le fonctionnement.

Concerning EVMs Including Detachable Antennas:

Under Industry Canada regulations, this radio transmitter may only operate using an antenna of a type and maximum (or lesser) gain approved for the transmitter by Industry Canada. To reduce potential radio interference to other users, the antenna type and its gain should be so chosen that the equivalent isotropically radiated power (e.i.r.p.) is not more than that necessary for successful communication. This radio transmitter has been approved by Industry Canada to operate with the antenna types listed in the user guide with the maximum permissible gain and required antenna impedance for each antenna type indicated. Antenna types not included in this list, having a gain greater than the maximum gain indicated for that type, are strictly prohibited for use with this device.

Concernant les EVMs avec antennes détachables

Conformément à la réglementation d'Industrie Canada, le présent émetteur radio peut fonctionner avec une antenne d'un type et d'un gain maximal (ou inférieur) approuvé pour l'émetteur par Industrie Canada. Dans le but de réduire les risques de brouillage radioélectrique à l'intention des autres utilisateurs, il faut choisir le type d'antenne et son gain de sorte que la puissance isotrope rayonnée équivalente (p.i.r.e.) ne dépasse pas l'intensité nécessaire à l'établissement d'une communication satisfaisante. Le présent émetteur radio a été approuvé par Industrie Canada pour fonctionner avec les types d'antenne énumérés dans le manuel d'usage et ayant un gain admissible maximal et l'impédance requise pour chaque type d'antenne. Les types d'antenne non inclus dans cette liste, ou dont le gain est supérieur au gain maximal indiqué, sont strictement interdits pour l'exploitation de l'émetteur.

3.3 Japan

3.3.1 *Notice for EVMs delivered in Japan:* Please see http://www.tij.co.jp/lstds/ti_ja/general/eStore/notice_01.page 日本国内に輸入される評価用キット、ボードについては、次のところをご覧ください。
http://www.tij.co.jp/lstds/ti_ja/general/eStore/notice_01.page

3.3.2 *Notice for Users of EVMs Considered "Radio Frequency Products" in Japan:* EVMs entering Japan may not be certified by TI as conforming to Technical Regulations of Radio Law of Japan.

If User uses EVMs in Japan, not certified to Technical Regulations of Radio Law of Japan, User is required by Radio Law of Japan to follow the instructions below with respect to EVMs:

1. Use EVMs in a shielded room or any other test facility as defined in the notification #173 issued by Ministry of Internal Affairs and Communications on March 28, 2006, based on Sub-section 1.1 of Article 6 of the Ministry's Rule for Enforcement of Radio Law of Japan,
2. Use EVMs only after User obtains the license of Test Radio Station as provided in Radio Law of Japan with respect to EVMs, or
3. Use of EVMs only after User obtains the Technical Regulations Conformity Certification as provided in Radio Law of Japan with respect to EVMs. Also, do not transfer EVMs, unless User gives the same notice above to the transferee. Please note that if User does not follow the instructions above, User will be subject to penalties of Radio Law of Japan.

【無線電波を送信する製品の開発キットをお使いになる際の注意事項】 開発キットの中には技術基準適合証明を受けていないものがあります。技術適合証明を受けていないものご使用に際しては、電波法遵守のため、以下のいずれかの措置を取っていただく必要がありますのでご注意ください。

1. 電波法施行規則第6条第1項第1号に基づく平成18年3月28日総務省告示第173号で定められた電波暗室等の試験設備でご使用いただく。
2. 実験局の免許を取得後ご使用いただく。
3. 技術基準適合証明を取得後ご使用いただく。

なお、本製品は、上記の「ご使用にあたっての注意」を譲渡先、移転先に通知しない限り、譲渡、移転できないものとします。

上記を遵守頂けない場合は、電波法の罰則が適用される可能性があることをご留意ください。日本テキサス・インスツルメンツ株式会社

東京都新宿区西新宿 6 丁目 2 4 番 1 号

西新宿三井ビル

3.3.3 *Notice for EVMs for Power Line Communication:* Please see http://www.tij.co.jp/llds/ti_ja/general/eStore/notice_02.page

電力線搬送波通信についての開発キットをお使いになる際の注意事項については、次のところをご覧ください。http://www.tij.co.jp/llds/ti_ja/general/eStore/notice_02.page

4 *EVM Use Restrictions and Warnings:*

4.1 EVMS ARE NOT FOR USE IN FUNCTIONAL SAFETY AND/OR SAFETY CRITICAL EVALUATIONS, INCLUDING BUT NOT LIMITED TO EVALUATIONS OF LIFE SUPPORT APPLICATIONS.

4.2 User must read and apply the user guide and other available documentation provided by TI regarding the EVM prior to handling or using the EVM, including without limitation any warning or restriction notices. The notices contain important safety information related to, for example, temperatures and voltages.

4.3 *Safety-Related Warnings and Restrictions:*

4.3.1 User shall operate the EVM within TI's recommended specifications and environmental considerations stated in the user guide, other available documentation provided by TI, and any other applicable requirements and employ reasonable and customary safeguards. Exceeding the specified performance ratings and specifications (including but not limited to input and output voltage, current, power, and environmental ranges) for the EVM may cause personal injury or death, or property damage. If there are questions concerning performance ratings and specifications, User should contact a TI field representative prior to connecting interface electronics including input power and intended loads. Any loads applied outside of the specified output range may also result in unintended and/or inaccurate operation and/or possible permanent damage to the EVM and/or interface electronics. Please consult the EVM user guide prior to connecting any load to the EVM output. If there is uncertainty as to the load specification, please contact a TI field representative. During normal operation, even with the inputs and outputs kept within the specified allowable ranges, some circuit components may have elevated case temperatures. These components include but are not limited to linear regulators, switching transistors, pass transistors, current sense resistors, and heat sinks, which can be identified using the information in the associated documentation. When working with the EVM, please be aware that the EVM may become very warm.

4.3.2 EVMs are intended solely for use by technically qualified, professional electronics experts who are familiar with the dangers and application risks associated with handling electrical mechanical components, systems, and subsystems. User assumes all responsibility and liability for proper and safe handling and use of the EVM by User or its employees, affiliates, contractors or designees. User assumes all responsibility and liability to ensure that any interfaces (electronic and/or mechanical) between the EVM and any human body are designed with suitable isolation and means to safely limit accessible leakage currents to minimize the risk of electrical shock hazard. User assumes all responsibility and liability for any improper or unsafe handling or use of the EVM by User or its employees, affiliates, contractors or designees.

4.4 User assumes all responsibility and liability to determine whether the EVM is subject to any applicable international, federal, state, or local laws and regulations related to User's handling and use of the EVM and, if applicable, User assumes all responsibility and liability for compliance in all respects with such laws and regulations. User assumes all responsibility and liability for proper disposal and recycling of the EVM consistent with all applicable international, federal, state, and local requirements.

5. *Accuracy of Information:* To the extent TI provides information on the availability and function of EVMs, TI attempts to be as accurate as possible. However, TI does not warrant the accuracy of EVM descriptions, EVM availability or other information on its websites as accurate, complete, reliable, current, or error-free.

6. *Disclaimers:*
- 6.1 EXCEPT AS SET FORTH ABOVE, EVMS AND ANY WRITTEN DESIGN MATERIALS PROVIDED WITH THE EVM (AND THE DESIGN OF THE EVM ITSELF) ARE PROVIDED "AS IS" AND "WITH ALL FAULTS." TI DISCLAIMS ALL OTHER WARRANTIES, EXPRESS OR IMPLIED, REGARDING SUCH ITEMS, INCLUDING BUT NOT LIMITED TO ANY IMPLIED WARRANTIES OF MERCHANTABILITY OR FITNESS FOR A PARTICULAR PURPOSE OR NON-INFRINGEMENT OF ANY THIRD PARTY PATENTS, COPYRIGHTS, TRADE SECRETS OR OTHER INTELLECTUAL PROPERTY RIGHTS.
- 6.2 EXCEPT FOR THE LIMITED RIGHT TO USE THE EVM SET FORTH HEREIN, NOTHING IN THESE TERMS AND CONDITIONS SHALL BE CONSTRUED AS GRANTING OR CONFERRING ANY RIGHTS BY LICENSE, PATENT, OR ANY OTHER INDUSTRIAL OR INTELLECTUAL PROPERTY RIGHT OF TI, ITS SUPPLIERS/LICENSORS OR ANY OTHER THIRD PARTY, TO USE THE EVM IN ANY FINISHED END-USER OR READY-TO-USE FINAL PRODUCT, OR FOR ANY INVENTION, DISCOVERY OR IMPROVEMENT MADE, CONCEIVED OR ACQUIRED PRIOR TO OR AFTER DELIVERY OF THE EVM.
7. *USER'S INDEMNITY OBLIGATIONS AND REPRESENTATIONS.* USER WILL DEFEND, INDEMNIFY AND HOLD TI, ITS LICENSORS AND THEIR REPRESENTATIVES HARMLESS FROM AND AGAINST ANY AND ALL CLAIMS, DAMAGES, LOSSES, EXPENSES, COSTS AND LIABILITIES (COLLECTIVELY, "CLAIMS") ARISING OUT OF OR IN CONNECTION WITH ANY HANDLING OR USE OF THE EVM THAT IS NOT IN ACCORDANCE WITH THESE TERMS AND CONDITIONS. THIS OBLIGATION SHALL APPLY WHETHER CLAIMS ARISE UNDER STATUTE, REGULATION, OR THE LAW OF TORT, CONTRACT OR ANY OTHER LEGAL THEORY, AND EVEN IF THE EVM FAILS TO PERFORM AS DESCRIBED OR EXPECTED.
8. *Limitations on Damages and Liability:*
- 8.1 *General Limitations.* IN NO EVENT SHALL TI BE LIABLE FOR ANY SPECIAL, COLLATERAL, INDIRECT, PUNITIVE, INCIDENTAL, CONSEQUENTIAL, OR EXEMPLARY DAMAGES IN CONNECTION WITH OR ARISING OUT OF THESE TERMS AND CONDITIONS OR THE USE OF THE EVMS PROVIDED HEREUNDER, REGARDLESS OF WHETHER TI HAS BEEN ADVISED OF THE POSSIBILITY OF SUCH DAMAGES. EXCLUDED DAMAGES INCLUDE, BUT ARE NOT LIMITED TO, COST OF REMOVAL OR REINSTALLATION, ANCILLARY COSTS TO THE PROCUREMENT OF SUBSTITUTE GOODS OR SERVICES, RETESTING, OUTSIDE COMPUTER TIME, LABOR COSTS, LOSS OF GOODWILL, LOSS OF PROFITS, LOSS OF SAVINGS, LOSS OF USE, LOSS OF DATA, OR BUSINESS INTERRUPTION. NO CLAIM, SUIT OR ACTION SHALL BE BROUGHT AGAINST TI MORE THAN ONE YEAR AFTER THE RELATED CAUSE OF ACTION HAS OCCURRED.
- 8.2 *Specific Limitations.* IN NO EVENT SHALL TI'S AGGREGATE LIABILITY FROM ANY WARRANTY OR OTHER OBLIGATION ARISING OUT OF OR IN CONNECTION WITH THESE TERMS AND CONDITIONS, OR ANY USE OF ANY TI EVM PROVIDED HEREUNDER, EXCEED THE TOTAL AMOUNT PAID TO TI FOR THE PARTICULAR UNITS SOLD UNDER THESE TERMS AND CONDITIONS WITH RESPECT TO WHICH LOSSES OR DAMAGES ARE CLAIMED. THE EXISTENCE OF MORE THAN ONE CLAIM AGAINST THE PARTICULAR UNITS SOLD TO USER UNDER THESE TERMS AND CONDITIONS SHALL NOT ENLARGE OR EXTEND THIS LIMIT.
9. *Return Policy.* Except as otherwise provided, TI does not offer any refunds, returns, or exchanges. Furthermore, no return of EVM(s) will be accepted if the package has been opened and no return of the EVM(s) will be accepted if they are damaged or otherwise not in a resalable condition. If User feels it has been incorrectly charged for the EVM(s) it ordered or that delivery violates the applicable order, User should contact TI. All refunds will be made in full within thirty (30) working days from the return of the components(s), excluding any postage or packaging costs.
10. *Governing Law:* These terms and conditions shall be governed by and interpreted in accordance with the laws of the State of Texas, without reference to conflict-of-laws principles. User agrees that non-exclusive jurisdiction for any dispute arising out of or relating to these terms and conditions lies within courts located in the State of Texas and consents to venue in Dallas County, Texas. Notwithstanding the foregoing, any judgment may be enforced in any United States or foreign court, and TI may seek injunctive relief in any United States or foreign court.

Mailing Address: Texas Instruments, Post Office Box 655303, Dallas, Texas 75265
Copyright © 2015, Texas Instruments Incorporated

IMPORTANT NOTICE

Texas Instruments Incorporated and its subsidiaries (TI) reserve the right to make corrections, enhancements, improvements and other changes to its semiconductor products and services per JESD46, latest issue, and to discontinue any product or service per JESD48, latest issue. Buyers should obtain the latest relevant information before placing orders and should verify that such information is current and complete. All semiconductor products (also referred to herein as "components") are sold subject to TI's terms and conditions of sale supplied at the time of order acknowledgment.

TI warrants performance of its components to the specifications applicable at the time of sale, in accordance with the warranty in TI's terms and conditions of sale of semiconductor products. Testing and other quality control techniques are used to the extent TI deems necessary to support this warranty. Except where mandated by applicable law, testing of all parameters of each component is not necessarily performed.

TI assumes no liability for applications assistance or the design of Buyers' products. Buyers are responsible for their products and applications using TI components. To minimize the risks associated with Buyers' products and applications, Buyers should provide adequate design and operating safeguards.

TI does not warrant or represent that any license, either express or implied, is granted under any patent right, copyright, mask work right, or other intellectual property right relating to any combination, machine, or process in which TI components or services are used. Information published by TI regarding third-party products or services does not constitute a license to use such products or services or a warranty or endorsement thereof. Use of such information may require a license from a third party under the patents or other intellectual property of the third party, or a license from TI under the patents or other intellectual property of TI.

Reproduction of significant portions of TI information in TI data books or data sheets is permissible only if reproduction is without alteration and is accompanied by all associated warranties, conditions, limitations, and notices. TI is not responsible or liable for such altered documentation. Information of third parties may be subject to additional restrictions.

Resale of TI components or services with statements different from or beyond the parameters stated by TI for that component or service voids all express and any implied warranties for the associated TI component or service and is an unfair and deceptive business practice. TI is not responsible or liable for any such statements.

Buyer acknowledges and agrees that it is solely responsible for compliance with all legal, regulatory and safety-related requirements concerning its products, and any use of TI components in its applications, notwithstanding any applications-related information or support that may be provided by TI. Buyer represents and agrees that it has all the necessary expertise to create and implement safeguards which anticipate dangerous consequences of failures, monitor failures and their consequences, lessen the likelihood of failures that might cause harm and take appropriate remedial actions. Buyer will fully indemnify TI and its representatives against any damages arising out of the use of any TI components in safety-critical applications.

In some cases, TI components may be promoted specifically to facilitate safety-related applications. With such components, TI's goal is to help enable customers to design and create their own end-product solutions that meet applicable functional safety standards and requirements. Nonetheless, such components are subject to these terms.

No TI components are authorized for use in FDA Class III (or similar life-critical medical equipment) unless authorized officers of the parties have executed a special agreement specifically governing such use.

Only those TI components which TI has specifically designated as military grade or "enhanced plastic" are designed and intended for use in military/aerospace applications or environments. Buyer acknowledges and agrees that any military or aerospace use of TI components which have **not** been so designated is solely at the Buyer's risk, and that Buyer is solely responsible for compliance with all legal and regulatory requirements in connection with such use.

TI has specifically designated certain components as meeting ISO/TS16949 requirements, mainly for automotive use. In any case of use of non-designated products, TI will not be responsible for any failure to meet ISO/TS16949.

Products

Audio	www.ti.com/audio
Amplifiers	amplifier.ti.com
Data Converters	dataconverter.ti.com
DLP® Products	www.dlp.com
DSP	dsp.ti.com
Clocks and Timers	www.ti.com/clocks
Interface	interface.ti.com
Logic	logic.ti.com
Power Mgmt	power.ti.com
Microcontrollers	microcontroller.ti.com
RFID	www.ti-rfid.com
OMAP Applications Processors	www.ti.com/omap
Wireless Connectivity	www.ti.com/wirelessconnectivity

Applications

Automotive and Transportation	www.ti.com/automotive
Communications and Telecom	www.ti.com/communications
Computers and Peripherals	www.ti.com/computers
Consumer Electronics	www.ti.com/consumer-apps
Energy and Lighting	www.ti.com/energy
Industrial	www.ti.com/industrial
Medical	www.ti.com/medical
Security	www.ti.com/security
Space, Avionics and Defense	www.ti.com/space-avionics-defense
Video and Imaging	www.ti.com/video

TI E2E Community

e2e.ti.com