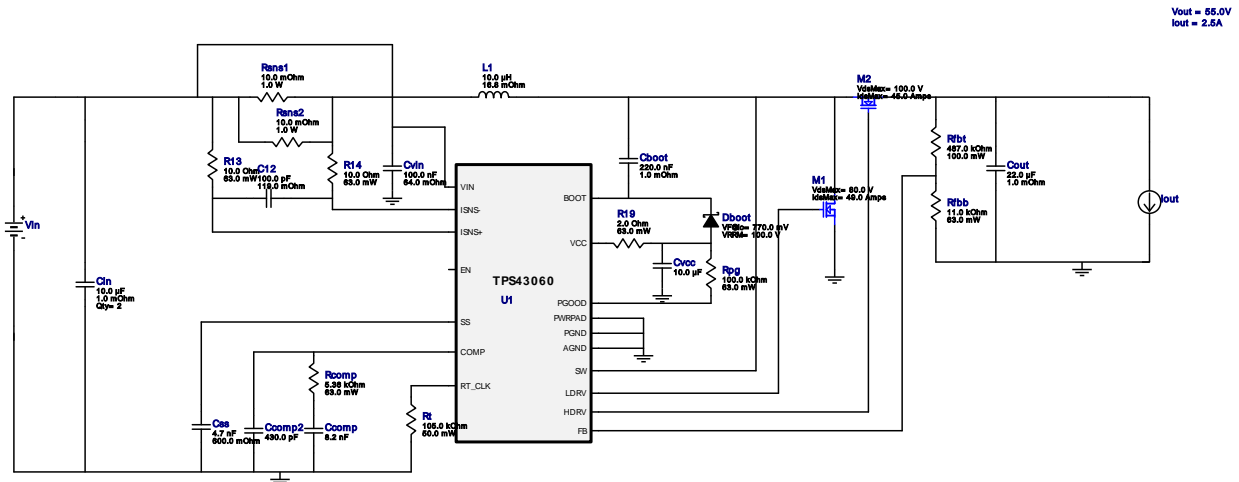

**WEBENCH® Design Report**

 Design : 25 TPS43060RTER  
 TPS43060RTER 20V-30V to 55.00V @ 2A

1. The pulse skip mode in the device has not been modeled. Efficiency and operational parameters of the model in pulse skip mode is not valid.

**Electrical BOM**

| Name   | Manufacturer | Part Number                            | Properties   | Qty | Price  | Footprint                   |
|--------|--------------|--|--|-----|--------|-----------------------------|
| C12    | AVX          | 06035A101JAT2A<br>Series= C0G/NP0      | Cap= 100.0 pF<br>ESR= 119.0 mOhm<br>VDC= 50.0 V<br>IRMS= 0.0 A | 1   | \$0.01 | 0603 5 mm <sup>2</sup>      |
| Cboot  | Kemet        | C0603C224Z4VACTU<br>Series= Y5V        | Cap= 220.0 nF<br>ESR= 1.0 mOhm<br>VDC= 16.0 V<br>IRMS= 0.0 A   | 1   | \$0.01 | 0603 5 mm <sup>2</sup>      |
| Ccomp  | TDK          | C2012C0G1H822K060AA<br>Series= C0G/NP0 | Cap= 8.2 nF<br>VDC= 50.0 V<br>IRMS= 0.0 A                      | 1   | \$0.05 | 0805 7 mm <sup>2</sup>      |
| Ccomp2 | MuRata       | GRM1555C1H431GA01D<br>Series= C0G/NP0  | Cap= 430.0 pF<br>VDC= 50.0 V<br>IRMS= 0.0 A                    | 1   | \$0.03 | 0402 3 mm <sup>2</sup>      |
| Cin    | MuRata       | GRM32ER71H106MA12<br>Series= X7R       | Cap= 10.0 uF<br>ESR= 1.0 mOhm<br>VDC= 50.0 V<br>IRMS= 0.0 A    | 2   | \$0.33 | 1210_270 15 mm <sup>2</sup> |
| Cout   | TDK          | CKG57NX7S2A226M500JH<br>Series= X7S    | Cap= 22.0 uF<br>ESR= 1.0 mOhm<br>VDC= 100.0 V<br>IRMS= 0.0 A   | 1   | \$2.36 | CKG57N 56 mm <sup>2</sup>   |
| Css    | MuRata       | GRM188R71E472KA01D<br>Series= X7R      | Cap= 4.7 nF<br>ESR= 600.0 mOhm<br>VDC= 25.0 V<br>IRMS= 0.0 A   | 1   | \$0.01 | 0603 5 mm <sup>2</sup>      |
| Cvcc   | Taiyo Yuden  | EMK107BBJ106MA-T<br>Series= X5R        | Cap= 10.0 uF<br>VDC= 16.0 V<br>IRMS= 0.0 A                     | 1   | \$0.07 | 0603 5 mm <sup>2</sup>      |
| Cvin   | Kemet        | C0805C104M5RACTU<br>Series= X7R        | Cap= 100.0 nF<br>ESR= 64.0 mOhm<br>VDC= 50.0 V<br>IRMS= 1.64 A | 1   | \$0.01 | 0805 7 mm <sup>2</sup>      |

| Name  | Manufacturer          | Part Number                          | Properties  | Qty | Price  | Footprint   |
|-------|-----------------------|--------------------------------------|---|-----|--------|---|
| Dboot | Diodes Inc.           | DFLS1100-7                           | VF@Io= 770.0 mV<br>VRRM= 100.0 V                      | 1   | \$0.14 | <br>PowerDI123 13 mm <sup>2</sup>    |
| L1    | Bourns                | SRP1270-100M                         | L= 10.0 µH<br>16.8 mOhm                               | 1   | \$0.72 | <br>SRP1270 246 mm <sup>2</sup>      |
| M1    | Infineon Technologies | BSC117N08NS5ATMA1                    | VdsMax= 80.0 V<br>IdsMax= 49.0 Amps                   | 1   | \$0.52 | <br>PG-TDSON-8 55 mm <sup>2</sup>    |
| M2    | Infineon Technologies | BSC196N10NSGATMA1                    | VdsMax= 100.0 V<br>IdsMax= 45.0 Amps                  | 1   | \$0.44 | <br>PG-TDSON-8 55 mm <sup>2</sup>    |
| R13   | Vishay-Dale           | CRCW040210R0FKED<br>Series= CRCW..e3 | Res= 10.0 Ohm<br>Power= 63.0 mW<br>Tolerance= 1.0%    | 1   | \$0.01 | <br>0402 3 mm <sup>2</sup>           |
| R14   | Vishay-Dale           | CRCW040210R0FKED<br>Series= CRCW..e3 | Res= 10.0 Ohm<br>Power= 63.0 mW<br>Tolerance= 1.0%    | 1   | \$0.01 | <br>0402 3 mm <sup>2</sup>           |
| R19   | Vishay-Dale           | CRCW04022R00FKED<br>Series= CRCW..e3 | Res= 2.0 Ohm<br>Power= 63.0 mW<br>Tolerance= 1.0%     | 1   | \$0.01 | <br>0402 3 mm <sup>2</sup>           |
| Rcomp | Vishay-Dale           | CRCW04025K36FKED<br>Series= CRCW..e3 | Res= 5.36 kOhm<br>Power= 63.0 mW<br>Tolerance= 1.0%   | 1   | \$0.01 | <br>0402 3 mm <sup>2</sup>           |
| Rfbb  | Vishay-Dale           | CRCW040211K0FKED<br>Series= CRCW..e3 | Res= 11.0 kOhm<br>Power= 63.0 mW<br>Tolerance= 1.0%   | 1   | \$0.01 | <br>0402 3 mm <sup>2</sup>         |
| Rfbt  | Vishay-Dale           | CRCW0603487KFKEA<br>Series= CRCW..e3 | Res= 487.0 kOhm<br>Power= 100.0 mW<br>Tolerance= 1.0% | 1   | \$0.01 | <br>0603 5 mm <sup>2</sup>         |
| Rpg   | Vishay-Dale           | CRCW0402100KFKED<br>Series= CRCW..e3 | Res= 100.0 kOhm<br>Power= 63.0 mW<br>Tolerance= 1.0%  | 1   | \$0.01 | <br>0402 3 mm <sup>2</sup>         |
| Rsns1 | Vishay-Dale           | WSLP1206R0100FEA<br>Series= WSL      | Res= 10.0 mOhm<br>Power= 1.0 W<br>Tolerance= 1.0%     | 1   | \$0.18 | <br>1206 11 mm <sup>2</sup>        |
| Rsns2 | Vishay-Dale           | WSLP1206R0100FEA<br>Series= WSL      | Res= 10.0 mOhm<br>Power= 1.0 W<br>Tolerance= 1.0%     | 1   | \$0.18 | <br>1206 11 mm <sup>2</sup>        |
| Rt    | Yageo                 | RC0201FR-07105KL<br>Series= ?        | Res= 105.0 kOhm<br>Power= 50.0 mW<br>Tolerance= 1.0%  | 1   | \$0.01 | <br>0201 2 mm <sup>2</sup>         |
| U1    | Texas Instruments     | TPS43060RTER                         | Switcher  | 1   | \$1.25 | <br>S-PVQFN-N16 17 mm <sup>2</sup> |

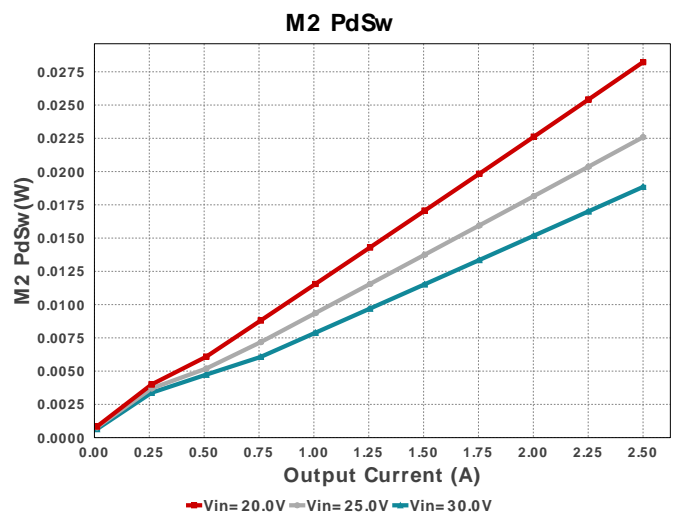
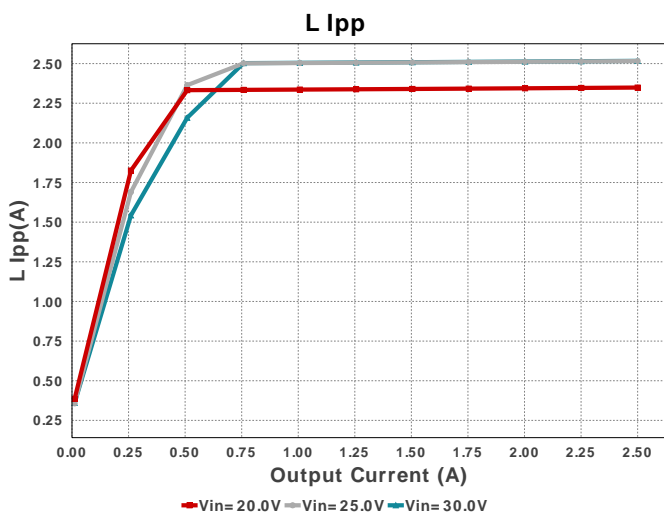
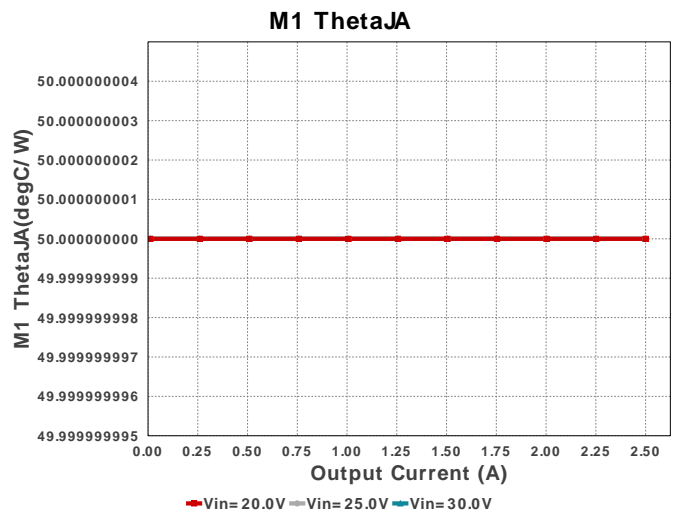
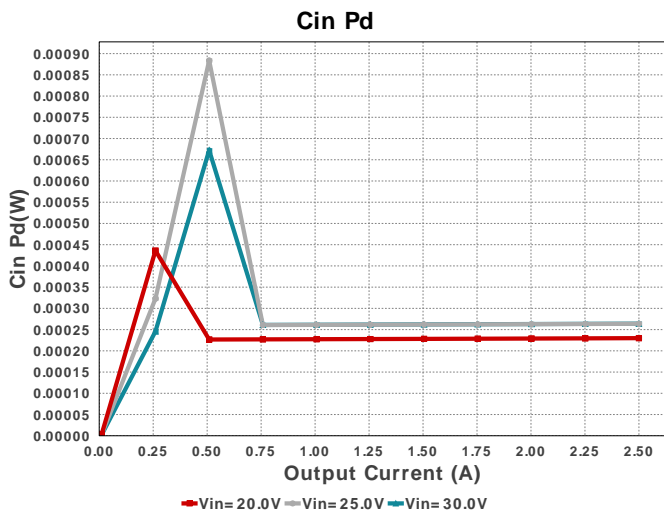
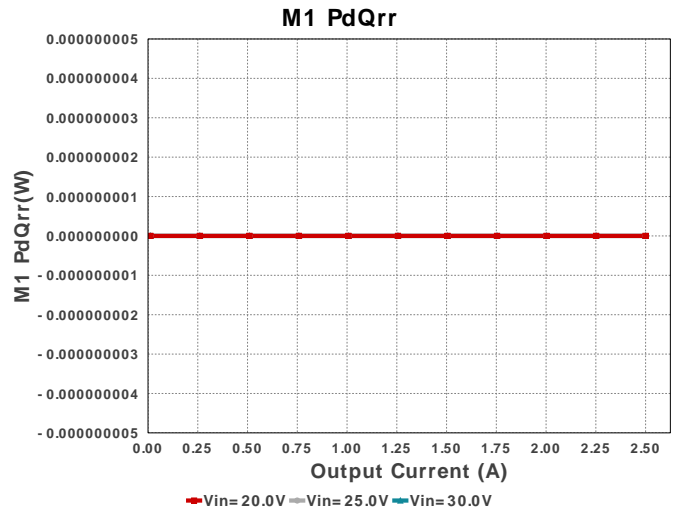
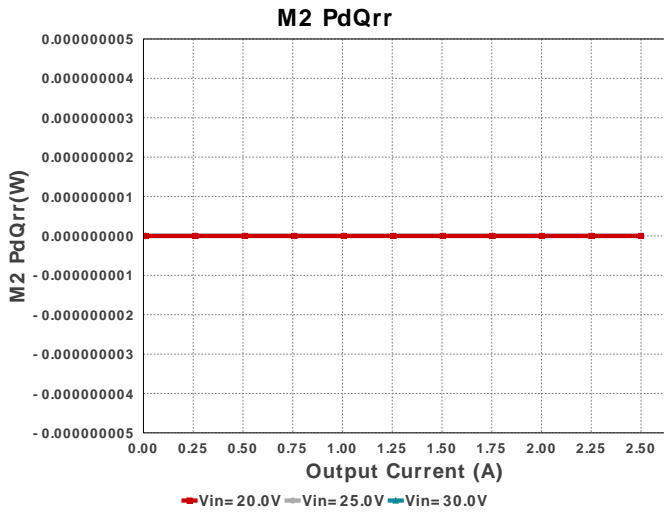

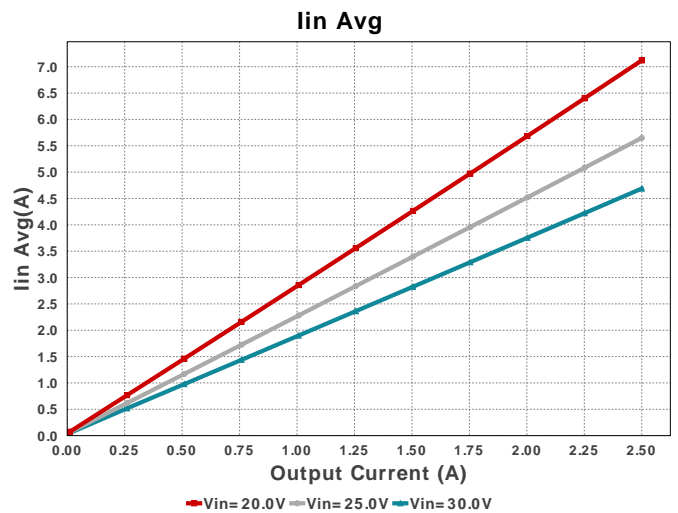
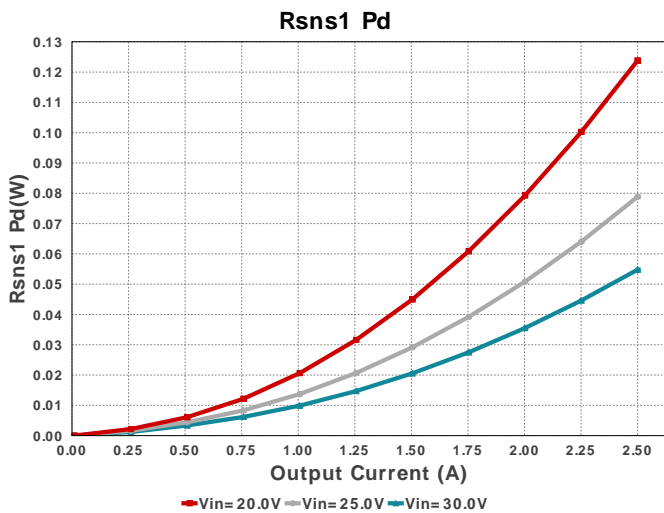
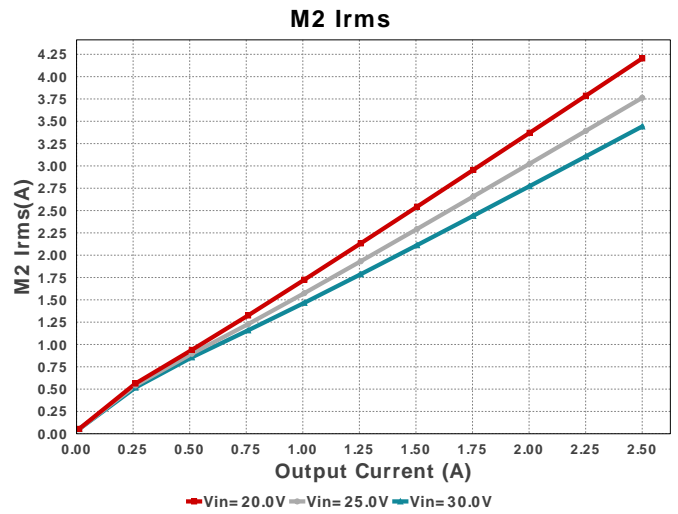
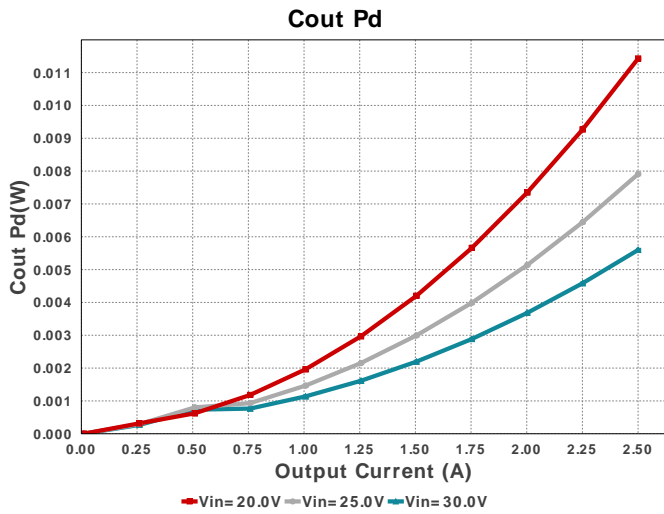
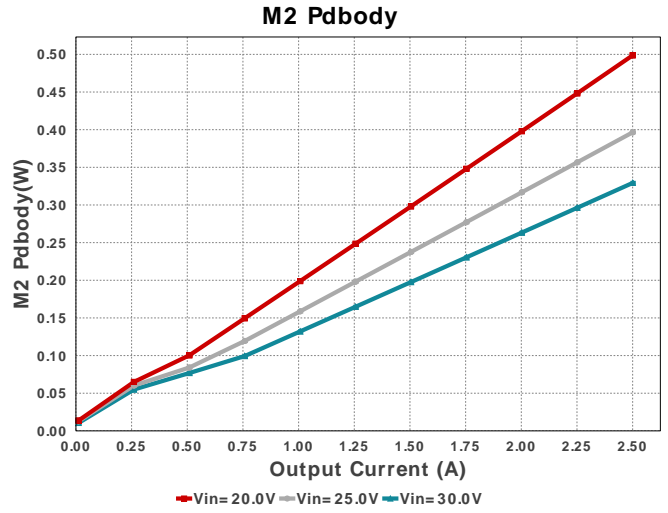
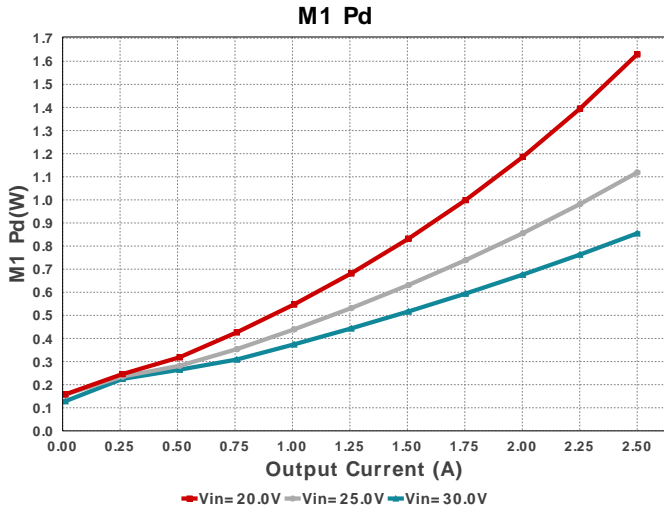

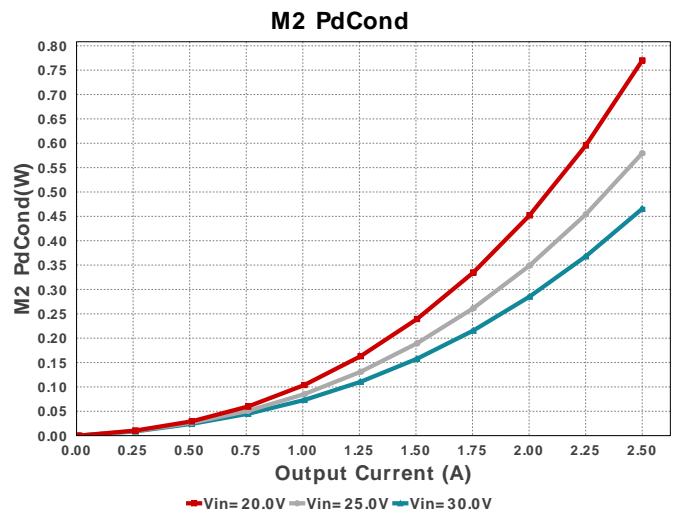
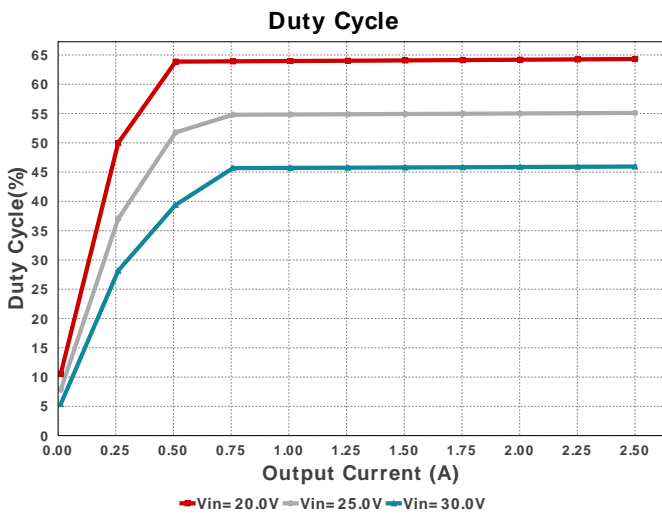
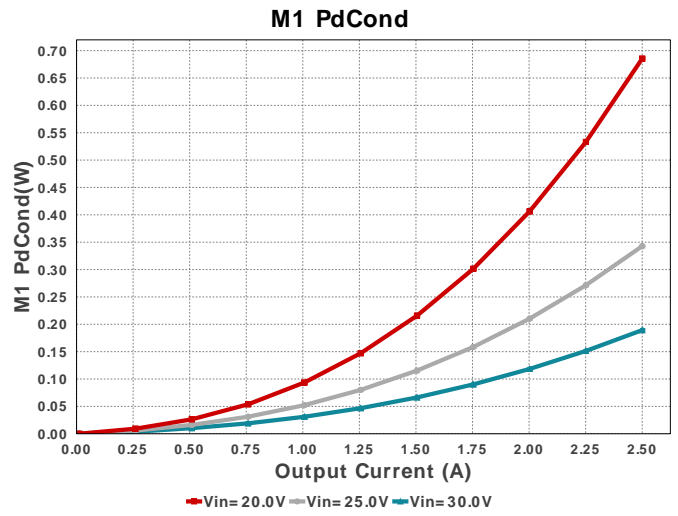
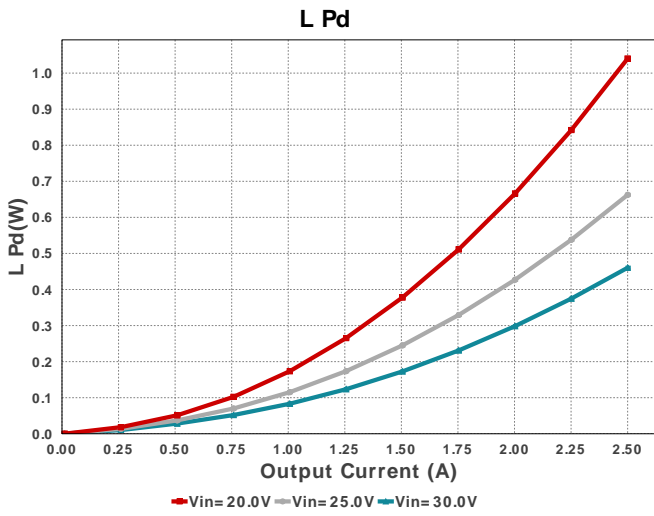
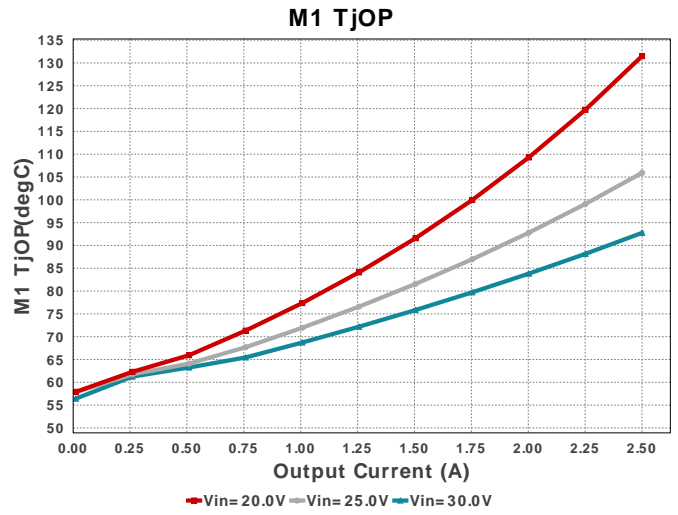
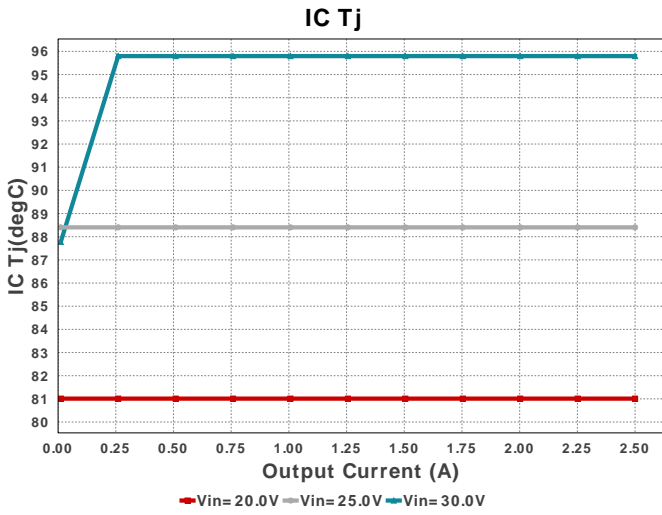

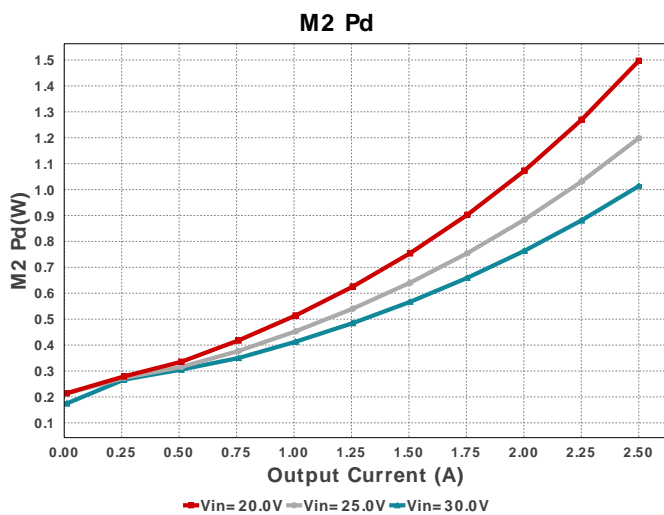
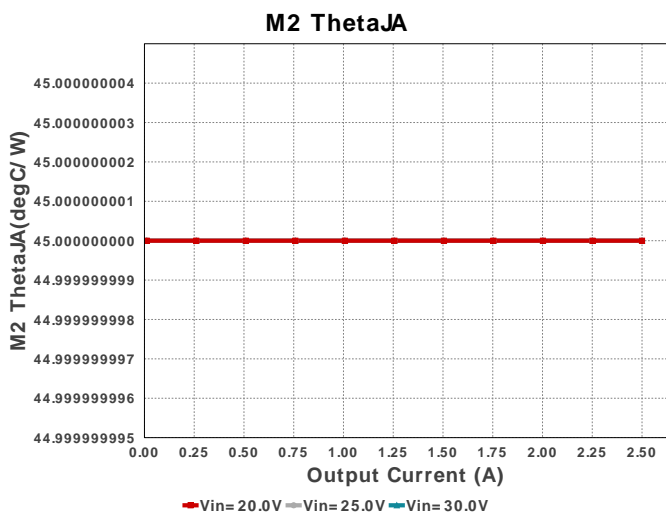
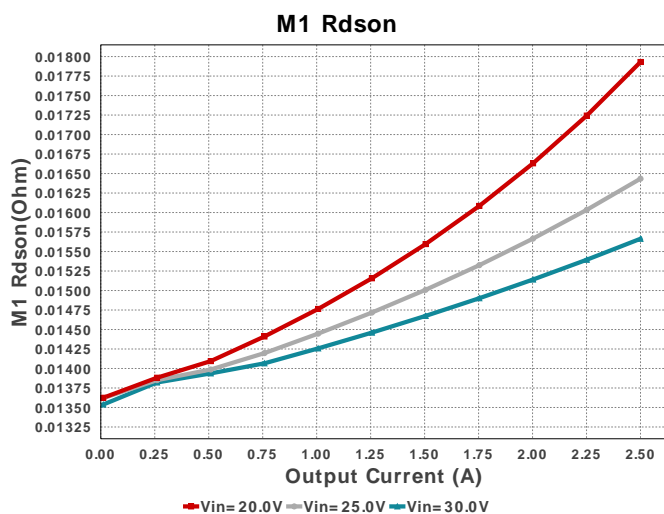
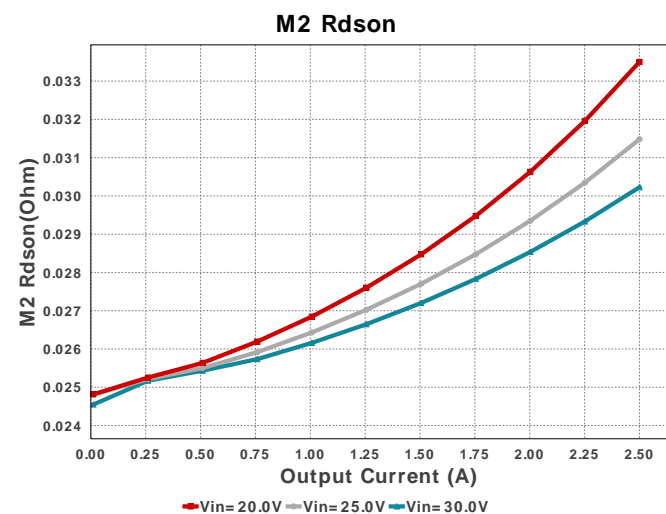
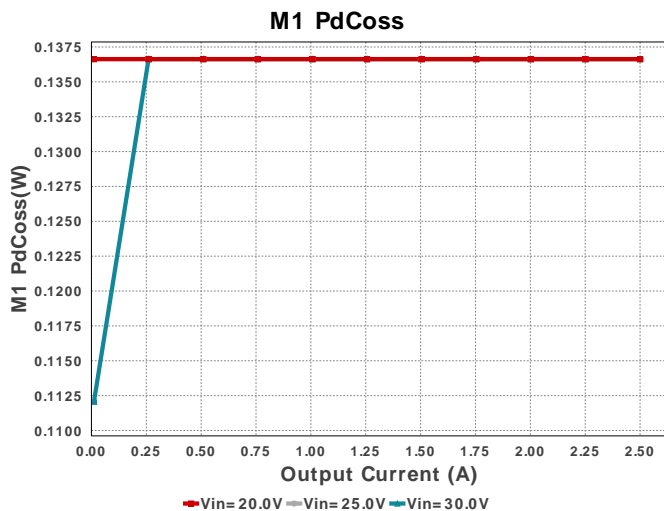
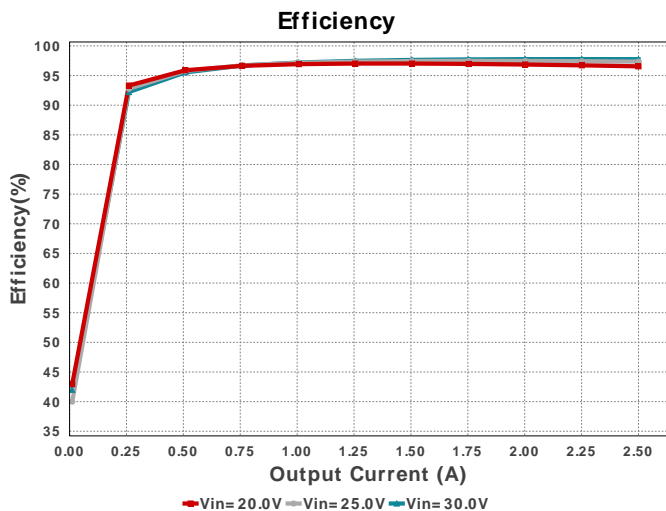

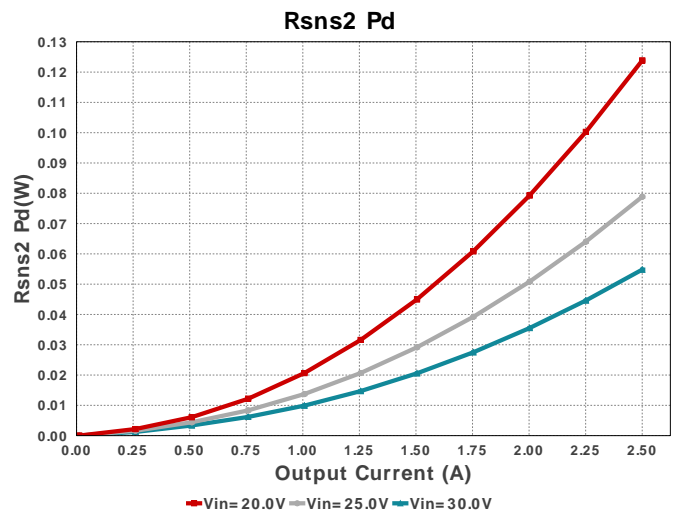
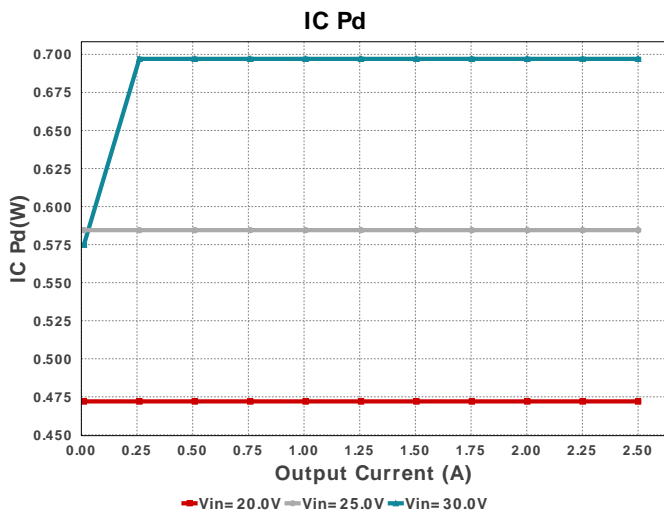
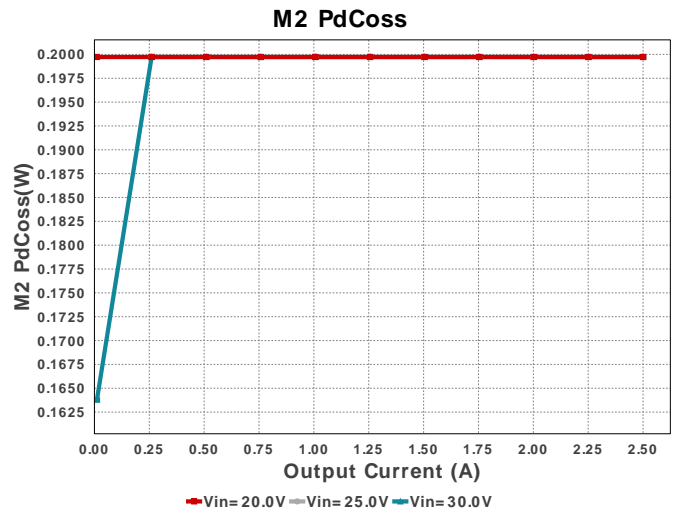
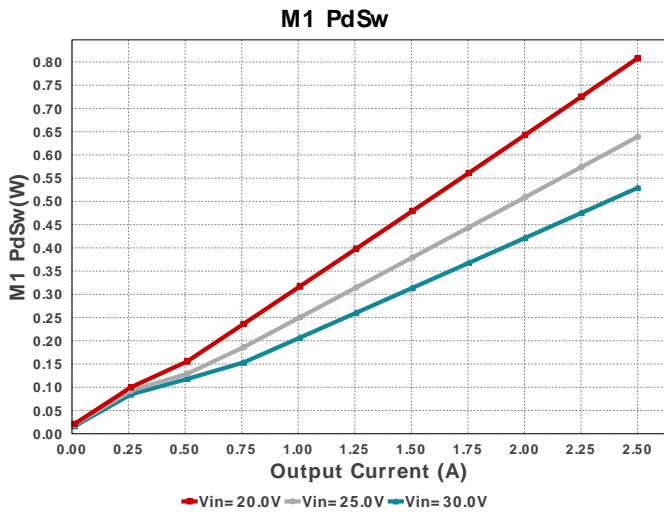
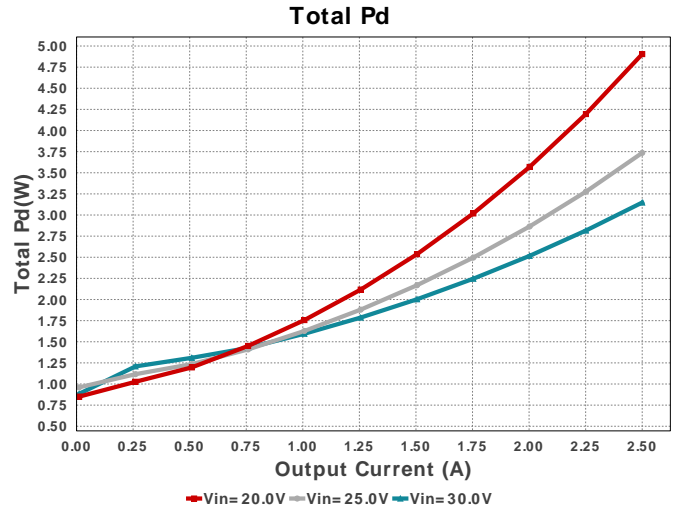
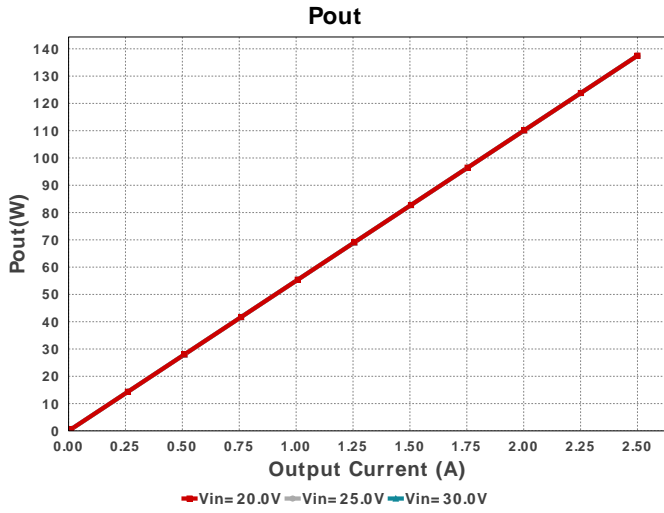

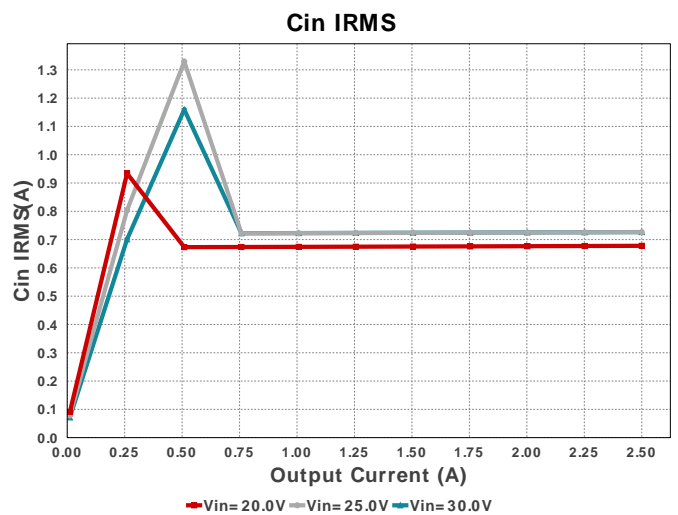
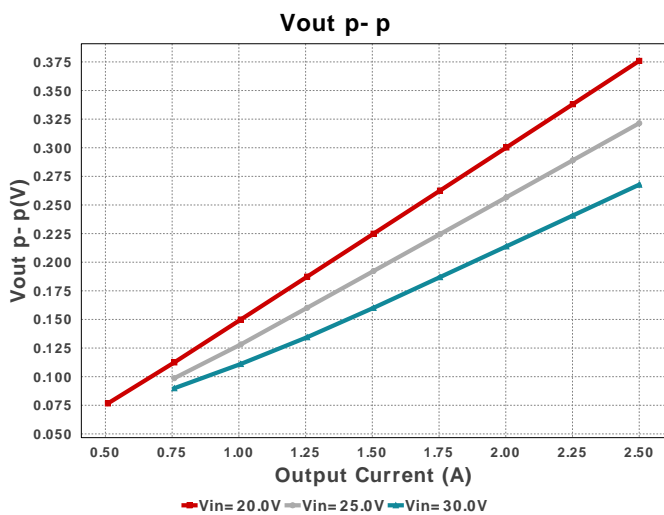
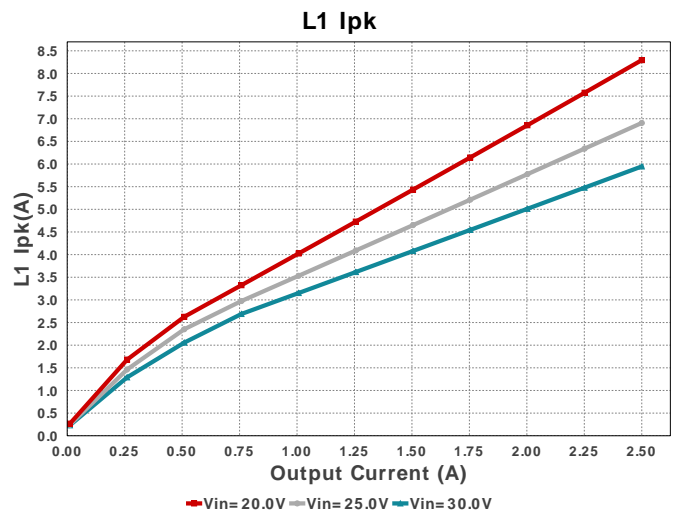
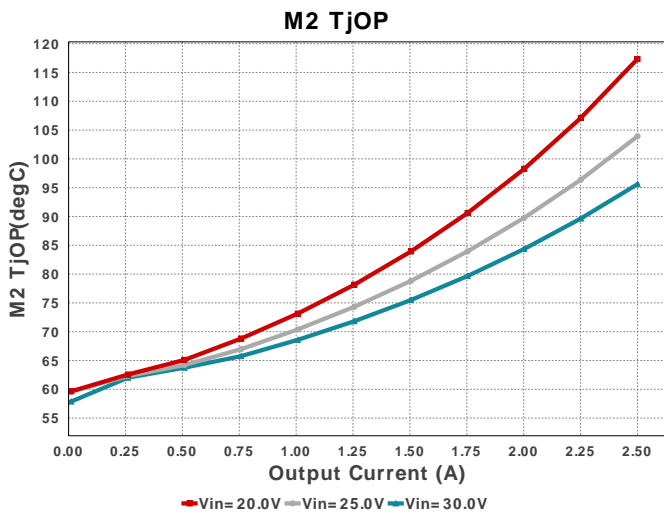
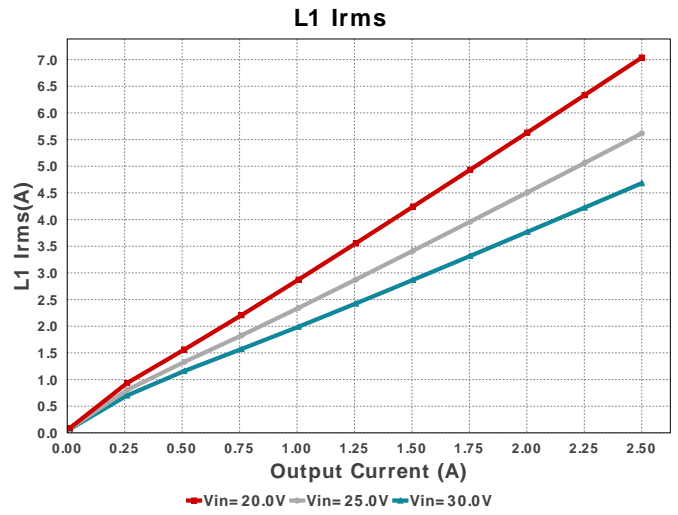
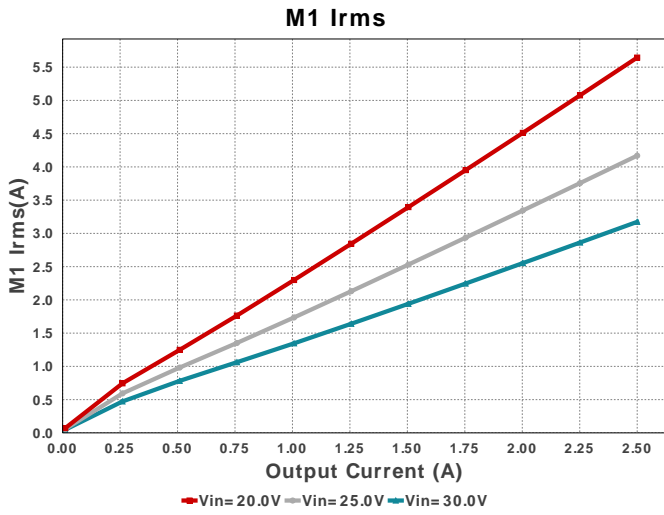



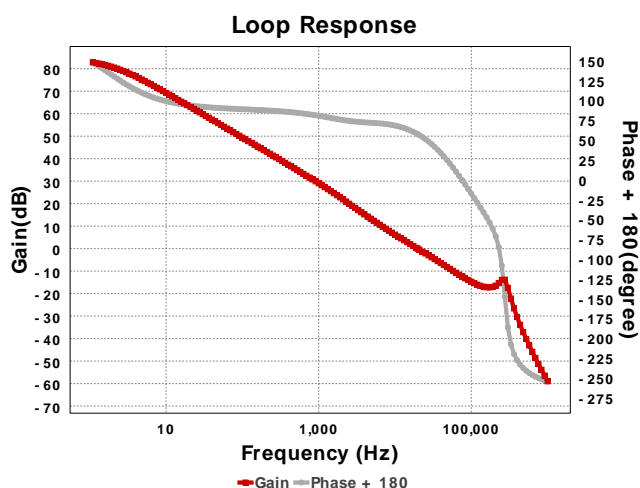

## Operating Values

| #   | Name       | Value          | Category           | Description                                   |
|-----|------------|----------------|--------------------|---|
| 1.  | Cin IRMS   | 678.039 mA     | Capacitor          | Input capacitor RMS ripple current            |
| 2.  | Cin Pd     | 229.87 $\mu$ W | Capacitor          | Input capacitor power dissipation             |
| 3.  | Cout Pd    | 11.426 mW      | Capacitor          | Output capacitor power dissipation            |
| 4.  | IC Pd      | 472.0 mW       | IC                 | IC power dissipation                          |
| 5.  | IC Tj      | 81.01 degC     | IC                 | IC junction temperature                       |
| 6.  | ICThetaJA  | 65.7 degC/W    | IC                 | IC junction-to-ambient thermal resistance     |
| 7.  | Iin Avg    | 7.12 A         | IC                 | Average input current                         |
| 8.  | L Ipp      | 2.349 A        | Inductor           | Peak-to-peak inductor ripple current          |
| 9.  | L Pd       | 1.04 W         | Inductor           | Inductor power dissipation                    |
| 10. | L1 Ipk     | 8.295 A        | Inductor           | Inductor peak current                         |
| 11. | L1 Irms    | 7.038 A        | Inductor           | Inductor ripple current                       |
| 12. | M1 Irms    | 5.644 A        | Mosfet             | MOSFET RMS ripple current                     |
| 13. | M1 Pd      | 1.63 W         | Mosfet             | MOSFET power dissipation                      |
| 14. | M1 PdCond  | 685.42 mW      | Mosfet             | M1 MOSFET conduction losses                   |
| 15. | M1 PdCoss  | 136.63 mW      | Mosfet             | M1 MOSFET Coss Losses                         |
| 16. | M1 PdQrr   | 0.0 W          | Mosfet             | M1 MOSFET switching losses                    |
| 17. | M1 PdSw    | 808.04 mW      | Mosfet             | M1 MOSFET switching losses                    |
| 18. | M1 Rdson   | 17.931 mOhm    | Mosfet             | Drain-Source On-resistance                    |
| 19. | M1 ThetaJA | 50.0 degC/W    | Mosfet             | MOSFET junction-to-ambient thermal resistance |
| 20. | M1 TjOP    | 131.5 degC     | Mosfet             | M1 MOSFET junction temperature                |
| 21. | M2 Irms    | 4.204 A        | Mosfet             | MOSFET RMS ripple current                     |
| 22. | M2 Pd      | 1.496 W        | Mosfet             | MOSFET power dissipation                      |
| 23. | M2 PdCond  | 769.83 mW      | Mosfet             | M2 MOSFET conduction losses                   |
| 24. | M2 PdCoss  | 199.73 mW      | Mosfet             | M2 MOSFET Coss Losses                         |
| 25. | M2 PdSw    | 28.229 mW      | Mosfet             | M2 MOSFET switching losses                    |
| 26. | M2 Pdbody  | 498.7 mW       | Mosfet             | Power dissipation through lower FET           |
| 27. | M2 Rdson   | 33.5 mOhm      | Mosfet             | Drain-Source On-resistance                    |
| 28. | M2 ThetaJA | 45.0 degC/W    | Mosfet             | MOSFET junction-to-ambient thermal resistance |
| 29. | M2 TjOP    | 117.34 degC    | Mosfet             | MOSFET junction temperature                   |
| 30. | Cin Pd     | 229.87 $\mu$ W | Power              | Input capacitor power dissipation             |
| 31. | Cout Pd    | 11.426 mW      | Power              | Output capacitor power dissipation            |
| 32. | IC Pd      | 472.0 mW       | Power              | IC power dissipation                          |
| 33. | L Pd       | 1.04 W         | Power              | Inductor power dissipation                    |
| 34. | M1 Pd      | 1.63 W         | Power              | MOSFET power dissipation                      |
| 35. | M1 PdCond  | 685.42 mW      | Power              | M1 MOSFET conduction losses                   |
| 36. | M1 PdCoss  | 136.63 mW      | Power              | M1 MOSFET Coss Losses                         |
| 37. | M1 PdQrr   | 0.0 W          | Power              | M1 MOSFET switching losses                    |
| 38. | M1 PdSw    | 808.04 mW      | Power              | M1 MOSFET switching losses                    |
| 39. | M2 Pd      | 1.496 W        | Power              | MOSFET power dissipation                      |
| 40. | M2 PdCond  | 769.83 mW      | Power              | M2 MOSFET conduction losses                   |
| 41. | M2 PdCoss  | 199.73 mW      | Power              | M2 MOSFET Coss Losses                         |
| 42. | M2 PdQrr   | 0.0 W          | Power              | Synchronous Boost High Side Reverse Recovery  |
| 43. | M2 PdSw    | 28.229 mW      | Power              | M2 MOSFET switching losses                    |
| 44. | M2 Pdbody  | 498.7 mW       | Power              | Power dissipation through lower FET           |
| 45. | Rsns1 Pd   | 123.83 mW      | Power              | Rsns1 Power Dissipation                       |
| 46. | Rsns2 Pd   | 123.83 mW      | Power              | Rsns2 Power Dissipation                       |
| 47. | Total Pd   | 4.904 W        | Power              | Total Power Dissipation                       |
| 48. | Rsns1 Pd   | 123.83 mW      | Resistor           | Rsns1 Power Dissipation                       |
| 49. | Rsns2 Pd   | 123.83 mW      | Resistor           | Rsns2 Power Dissipation                       |
| 50. | BOM Count  | 25             | System Information | Total Design BOM count                        |

| #   | Name           | Value                 | Category           | Description  |
|-----|----------------|-----------------------|--------------------|--|
| 51. | Cross Freq     | 13.776 kHz            | System Information | Bode plot crossover frequency  |
| 52. | Duty Cycle     | 64.312 %              | System Information | Duty cycle   |
| 53. | Efficiency     | 96.556 %              | System Information | Steady state efficiency  |
| 54. | FootPrint      | 554.0 mm <sup>2</sup> | System Information | Total Foot Print Area of BOM components  |
| 55. | Frequency      | 547.619 kHz           | System Information | Switching frequency  |
| 56. | Gain Marg      | -10.292 dB            | System Information | Bode Plot Gain Margin  |
| 57. | Iout           | 2.5 A                 | System Information | Iout operating point   |
| 58. | Low Freq Gain  | 80.795 dB             | System Information | Gain at 1Hz  |
| 59. | Mode           | CCM                   | System Information | Conduction Mode  |
| 60. | Phase Marg     | 55.57 deg             | System Information | Bode Plot Phase Margin   |
| 61. | Pout           | 137.5 W               | System Information | Total output power   |
| 62. | Total BOM      | \$6.72                | System Information | Total BOM Cost   |
| 63. | Vin            | 20.0 V                | System Information | Vin operating point  |
| 64. | Vout           | 55.0 V                | System Information | Operational Output Voltage   |
| 65. | Vout Actual    | 55.233 V              | System Information | Vout Actual calculated based on selected voltage divider resistors                         |
| 66. | Vout Tolerance | 4.065 %               | System Information | Vout Tolerance based on IC Tolerance (no load) and voltage divider resistors if applicable |
| 67. | Vout p-p       | 375.907 mV            | System Information | Peak-to-peak output ripple voltage   |

## Design Inputs

| Name    | Value    | Description            |
|---------|----------|------------------------|
| Iout    | 2.5      | Maximum Output Current |
| VinMax  | 30.0     | Maximum input voltage  |
| VinMin  | 20.0     | Minimum input voltage  |
| Vout    | 55.0     | Output Voltage         |
| base_pn | TPS43060 | Base Product Number    |
| source  | DC       | Input Source Type      |
| Ta      | 50.0     | Ambient temperature    |

## WEBENCH® Assembly

### Component Testing

Some published data on components in datasheets such as Capacitor ESR and Inductor DC resistance is based on conservative values that will guarantee that the components always exceed the specification. For design purposes it is usually better to work with typical values. Since this data is not always available it is a good practice to measure the Capacitance and ESR values of  $C_{in}$  and  $C_{out}$ , and the inductance and DC resistance of L1 before assembly of the board. Any large discrepancies in values should be electrically simulated in WEBENCH to check for instabilities and thermally simulated in WebTHERM to make sure critical temperatures are not exceeded.

### Soldering Component to Board

If board assembly is done in house it is best to tack down one terminal of a component on the board then solder the other terminal. For surface mount parts with large tabs, such as the DPAK, the tab on the back of the package should be pre-tinned with solder, then tacked into place by one of the pins. To solder the tab down to the board place the iron down on the board while resting against the tab, heating both surfaces simultaneously. Apply light pressure to the top of the plastic case until the solder flows around the part and the part is flush with the PCB. If the solder is not flowing around the board you may need a higher wattage iron (generally 25W to 30W is enough).

### Initial Startup of Circuit

It is best to initially power up the board by setting the input supply voltage to the lowest operating input voltage 20.0V and set the input supply's current limit to zero. With the input supply off connect up the input supply to  $V_{in}$  and GND. Connect a digital volt meter and a load if needed to set the minimum load of the design from  $V_{out}$  and GND. Turn on the input supply and slowly turn up the current limit on the input supply. If the voltage starts to rise on the input supply continue increasing the input supply current limit while watching the output voltage. If the current increases on the input supply, but the voltage remains near zero, then there may be a short or a component misplaced on the board. Power down the board and visually inspect for solder bridges and recheck the diode and capacitor polarities. Once the power supply circuit is operational then more extensive testing may include full load testing, transient load and line tests to compare with simulation results.

### Load Testing

The setup is the same as the initial startup, except that an additional digital voltmeter is connected between  $V_{in}$  and GND, a load is connected between  $V_{out}$  and GND and a current meter is connected in series between  $V_{out}$  and the load. The load must be able to handle at least rated output power + 50% ( 7.5 watts for this design). Ideally the load is supplied in the form of a variable load test unit. It can also be done in the form of suitably large power resistors. When using an oscilloscope to measure waveforms on the prototype board, the ground leads of the oscilloscope probes should be as short as possible and the area of the loop formed by the ground lead should be kept to a minimum. This will help reduce ground lead inductance and eliminate EMI noise that is not actually present in the circuit.

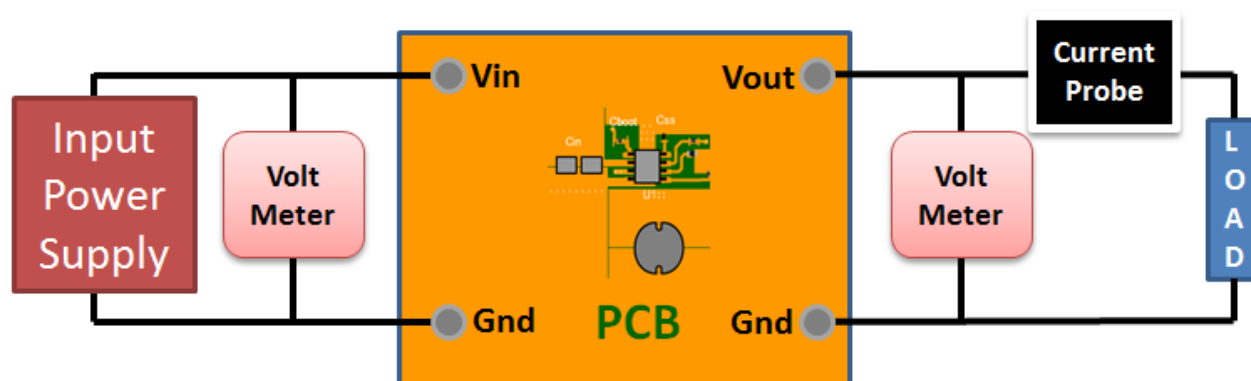

### Design Assistance

1. Feature Highlights: Low Quiescent Current Boost Controller, Wide  $V_{in}$  Range 4.5V to 38V  $V_{in}$ , 58V  $V_{out}$ , 7.5V Gate Drive optimized for standard MOSFET Thresholds Thermal Shutdown
2. Master key : E092C2B2C1AE31CE[v1]
3. **TPS43060** Product Folder : <http://www.ti.com/product/TPS43060> : contains the data sheet and other resources.

**Important Notice and Disclaimer**

TI provides technical and reliability data (including datasheets), design resources (including reference designs), application or other design advice, web tools, safety information, and other resources AS IS and with all faults, and disclaims all warranties. These resources are intended for skilled developers designing with TI products. You are solely responsible for (1) selecting the appropriate TI products for your application, (2) designing, validating and testing your application, and (3) ensuring your application meets applicable standards, and any other safety, security, or other requirements.

These resources are subject to change without notice. TI grants you permission to use these resources only for development of an application that uses the TI products described in the resource. Other reproduction and display of these resources is prohibited. No license is granted to any other TI intellectual property right or to any third party intellectual property right. TI disclaims responsibility for, and you will fully indemnify TI and its representatives against, any claims, damages, costs, losses, and liabilities arising out of your use of these resources.

Providing these resources does not expand or otherwise alter TI's applicable Terms of Sale or other applicable terms available either on ti.com or provided in conjunction with TI products.