

Ideal Diode Controller (RPP/OVP/UVP/Inrush/Batt Monitor)

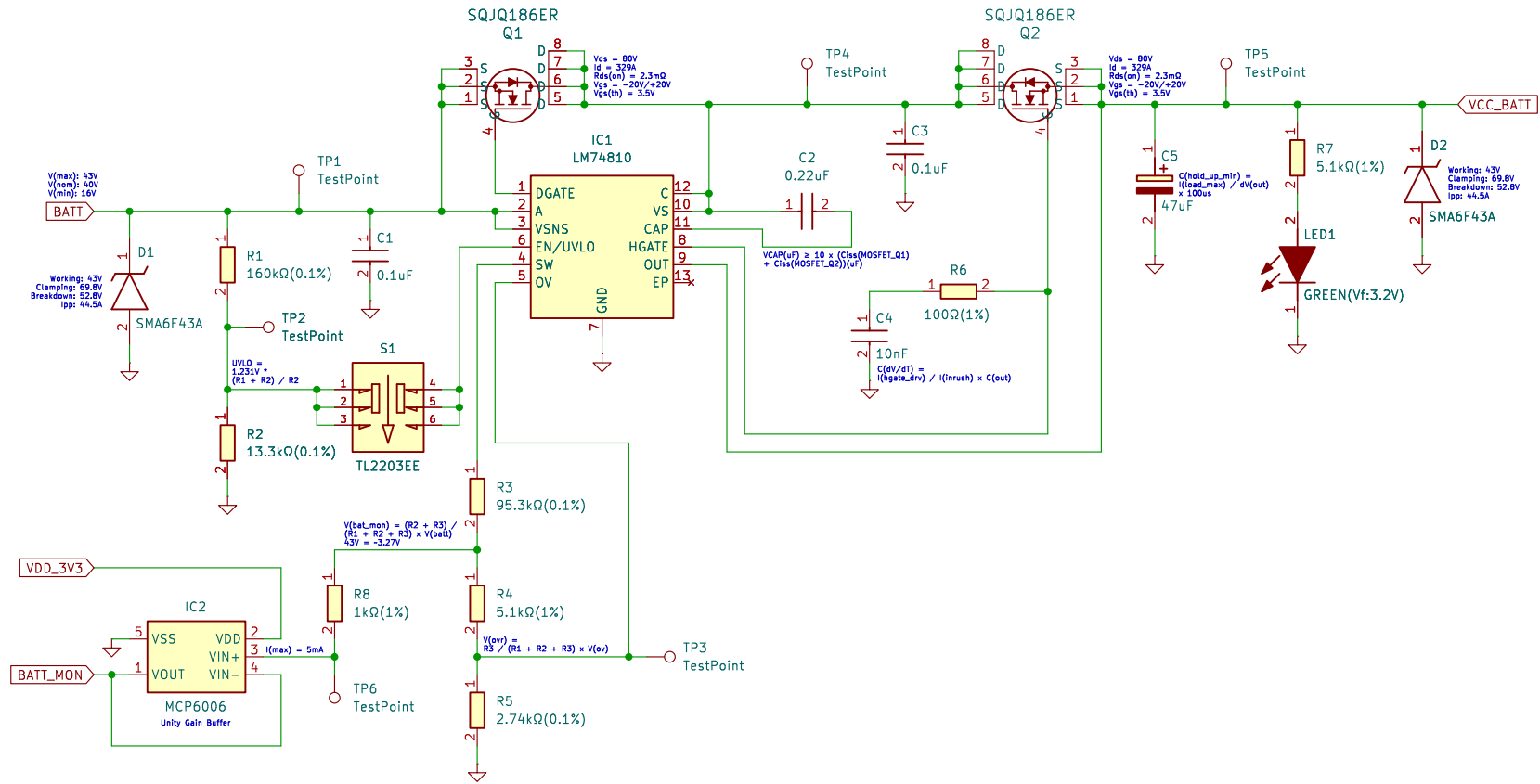

VIN(max): 43V, VIN(min): 16V
I(max): 40A

Sheet: /Ideal_Diode_Controller/
File: ideal_diode_controller.kicad_sch

Title: Ideal Diode Controller

Size: A4 Date: 01/10/2024
KiCad E.D.A. 8.0.4

Rev: 0
Id: 2/10