

UCC28740 DESIGN CALCULATOR

TI Literature Number: SLUC487B

Disclaimer

This product is designed as an aid for customers of Texas Instruments. No warranties, either of fitness for any particular purpose, are claimed by Texas Instruments or the author. The software is provided to its quality and performance is with the customer's discretion.

UCC28740 CONSTANT-VOLTAGE, CONSTANT-CURRENT MODE

CLEAR ALL USER INPUT CELLS BEFORE START
ALL GREEN CELLS ARE USER INPUTS

WHERE APPLICABLE, A RECOMMENDED VALUE IS GIVEN THAT WILL BE THE BEST CHOICE FOR THE BEST INTEREST OF THE USER TO USE A VALUE AS CLOSE AS POSSIBLE TO THE RECOMMENDED VALUE. FOR MORE ACCURATE RESULTS, THE USER MUST ENTER THE ACTUAL VALUE USED.

DESIGN REQUIREMENTS

INPUT SPECIFICATIONS

Input Voltage Type, AC or DC:	AC	
Minimum Input Voltage, $V_{\text{INPUTmin}} =$	85	VAC
Maximum Input Voltage, $V_{\text{INPUTmax}} =$	265	VAC
Nominal Input Voltage, $V_{\text{INPUTnom}} =$	220	VAC
Minimum Line Frequency, $f_{\text{LINEmin}} =$	47	Hz
Minimum Input Voltage for Start-Up, $V_{\text{INPUTrun}} =$	80	VAC

OUTPUT SPECIFICATIONS

Regulated Output Voltage, Constant Voltage Mode, $V_{\text{OUT CV}} =$	80	VDC
Full Load Rated Output Current, $I_{\text{OUT}} =$	0.6	A
Target Constant Current Mode Output Load Threshold, $I_{\text{OCC}} =$	0.7	A
Target Minimum Output Voltage During Constant Current Regulation, $V_{\text{OUT CC}} =$	78	VDC
Allowable Output Voltage Drop During Load-Step Transient in Constant Voltage Mode, $V_{\text{OUT}\Delta} =$	5	V
Maximum Peak to Peak Output Voltage Ripple, $V_{\text{RIPPLE}} =$	30	mV

Maximum Desired Switching Frequency, User must input value not greater than 100 kHz, $f_{max} =$	100	kHz
Output Over Voltage Protection, $V_{OUT_OVP} =$	85	V
Required Positive Load Step Transient Current, $I_{TRAN} =$	0.7	A
Maximum Allowable Response Time to Load Step Transient, $t_{RESP} =$	20	ms
Target Maximum Stand By Power Dissipation, $P_{SBtarget} =$	50	mW

COMPONENT SELECTION USER INPUT

COMPONENT	PARAMETER	
Input Capacitor, C_{BULK}		
Desired Minimum Valley Voltage, $V_{BULKvalley_desired} =$	100	V
Recommended Input Bulk Capacitance, $C_{BULK} =$	256.01	μ F
Actual Input Bulk Capacitance, C_{BULK} , Used =	256.00	μ F
Output Rectifier, D_{OUT}		
Forward Voltage Drop of Output Rectifier, $V_F =$	1.38	V
Output Inductor, L_{OUT}		
DCR of Output Inductor, DCR_{Lout} , if used =	0	m Ω

Flyback Transformer, Primary to Secondary Turns Ratio

Ideal Primary to Secondary Turns Ratio, $N_{PSideal} =$	1.373	
Actual Primary to Secondary Turns Ratio Used, $N_{PS} =$	1.373	Enter Actual N_{PS} of Transformer Used
Current Sense Resistor, R_{CS}		
Recommended Current Sense Resistor, $R_{CS} =$	0.302	Ω
Actual Current Sense Resistor Used, $R_{CS} =$	0.282	Ω
Flyback Transformer, T		
Recommended Primary Inductance Value, $L_P =$	192.488	μ H

Actual Primary Inductance Used, $L_p =$	192.500	μH
Recommended Primary to Auxillary Turns Ratio, $N_{PA} =$	12.178	Suggested N_p
Actual Primary to Auxiliary Turns Ratio, $N_{PA} =$	10.000	Enter Actual N_{PA} of Transformer Used
MOSFET Switch, Q		
Required Drain to Soure Voltage Rating , $V_{DS\text{rated}} =$	632.452	V
MOSFET Rated Drain to Source Voltage, $V_{DS} =$	700	V
Output Capacitance of Selected MOSFET, $C_{OSS} =$	100	pF
Drain to Source On-Resistance of Selected MOSFET, $R_{DSon} =$	0.45	Ω
MOSFET Fall Time, $t_f =$	12	ns
MOSFET Turn Off Delay Time, $t_{Doff} =$	39	ns
MOSFET Total Gate Charge, $Q_g =$	14	nC

Output Capacitor, C_{OUT}		
Recommended Minimum Output Capacitance, $C_{OUT} =$	680.000	μF
Actual Minimum Output Capacitance, $C_{OUT} =$	680.000	μF
Recommended Maximum ESR, $ESR_{Cout} =$	7.971	m Ω
Actual ESR of C_{OUT} Used, $ESR_{Cout} =$	50.000	m Ω
Bridge Rectifier, D_{BRIDGE}		
Forward Voltage Drop, $V_{F_BRIDGE} =$	1	V
Auxiliary Winding Rectifier, D_{AUX}		
Auxiliary Rectifier Forward Voltage Drop, $V_{FA} =$	0.8	V
Input Line Voltage Turn On Resistor, R_{VS1}		
Recommended Value for R_{VS1} , $R_{VS1} =$	40.200	k Ω
Actual Value for R_{VS1} , $R_{VS1} =$	40.000	k Ω
Output Over Voltage Resistor, R_{VS2}		
Recommended Value for R_{VS2} , $R_{VS2} =$	26.100	k Ω
Actual Value for R_{VS2} , $R_{VS2} =$	26.000	k Ω
Line Compensation Resistor, R_{LC}		
Recommended Value for R_{LC} , $R_{LC} =$	1.330	k Ω
Actual Value for R_{LC} , $R_{LC} =$	1.300	k Ω
Loop Compensation Components, R_{FB1}, R_{FB2}, R_{TL}, R_{OPT}, C_{FB}, C_{EXT}, R_{FB3}, R_{FB4}, C_Z		

Reference Voltage of Shunt Regulator, i.e. TL431, $V_{REF431} =$	80	V
Maximum Reference Input Current of Shunt Regulator, $I_{REF431} =$	110	μ A
Recommended Value for $R_{FB2}, R_{FB2} =$	51.1	k Ω
Actual Value for $R_{FB2}, R_{FB2} =$	51	k Ω
Recommended Value for $R_{FB1}, R_{FB1} =$	Err:502	k Ω
Actual Value for $R_{FB1}, R_{FB1} =$	9.5	k Ω
Minimum Current Transfer Ratio of Selected Opto-Coupler, $CTR_{min} =$	50	%
Response Fall Time of Opto-Coupler, $t_{f_{opto}} =$	18	μ s
R_L of Specified Opto-Coupler Fall Time, $R_{L_{opto}} =$	100	Ω
Cut-Off Frequency of Opto-Coupler, $f_{c_{opto}} =$	80	kHz
Input Forward Voltage of Opto-Coupler, $V_{F_{opto}} =$	1.2	V
Recommended External Capacitor Across Opto-Coupler Output, $C_{EXT} =$	0	μ F
Actual Value for C_{EXT} Used , $C_{EXT} =$	0	μ F
Recommended Capacitor on Opto_Coupler Emitter, $C_{FB} =$	0.047	μ F
Actual Value for C_{FB} Used, $C_{FB} =$	0.047	μ F
Recommended Value For $R_{FB4}, R_{FB4} =$	22	k Ω
Actual Value for R_{FB4} Used	22	k Ω
Recommended Value for Shunt Regulator Bias Resistor, $R_{TL} =$	1.5	k Ω
Actual Value of Shunt Regulator Bias Resistor Used, $R_{TL} =$	1.5	k Ω
Recommended Value for Compensation Capacitor, $C_Z =$	22000	pF
Actual Value of Compensation Capacitor Used, $C_Z =$	22000	pF

ATOR TOOL

expressed or implied, with respect to this software or its use. This software is licensed solely on an "as is" basis. The entire risk as to the accuracy of the results is borne by the user.

FEEDBACK DESIGN CALCULATOR

STARTING A NEW DESIGN

INPUTS

ENTER THE VALUES TO MEET THE GIVEN SPECIFICATION. IT IS IN THE SUGGESTED RECOMMENDED VALUE. FOR THE FREQUENCY, ENTERED IN THE APPROPRIATE CELL.

Choose either AC or DC

For universal line enter 47 Hz

UTS

COMMENT

Used to determine the required input bulk capacitor at minimum line, full load. For DC input, use $V_{INPUTrun}$

Using a value less than recommended will result in a minimum valley voltage less than desired, requiring a larger power stage to accommodate the higher currents due to the lower input rail. Using a value larger than recommended will result in a higher input rail and lower currents on the power stage but higher peak current in the input capacitor itself.

Enter actual input bulk capacitor used

Enter V_F at full load

Enter 0 if no secondary LC filter used

Recommended N_{PS}

Recommended R_{CS}

Enter Actual R_{CS} Used

A

Recommended C_{OUT}
Enter Actual C_{OUT} Used
Recommended ESR
Enter Actual ESR of C_{OUT} Used
At I_{INPEAK} Not Applicable for DC input
Recommended R_{VS1}
Enter Actual R_{VS1} Used
Recommended R_{VS2}
Enter Actual R_{VS2} Used
Recommended R_{LC}
Enter Actual R_{LC} Used

Enter Nominal V_{REF} Used
Enter Reference Pin Input Current
Recommended R_{FB2}
Enter Actual R_{FB2} Used
Recommended R_{FB1}
Enter Actual R_{FB1} Used
Enter CTR_{min}
Enter Opto-Coupler t_f
Enter R_L from Opto-Coupler t_f spec
Enter Opto-Coupler Cut-Off Frequency
Enter Maximum V_F of Opto-Coupler
Recommended C_{EXT}
Enter Actual C_{EXT} Used
Recommended C_{FB}
Enter Actual C_{FB} Used
Recommended R_{FB4}
Enter Actual R_{FB4} Used
Recommended R_{TL}
Enter Actual R_{TL} Used
Recommended C_Z
Enter Actual C_Z Used

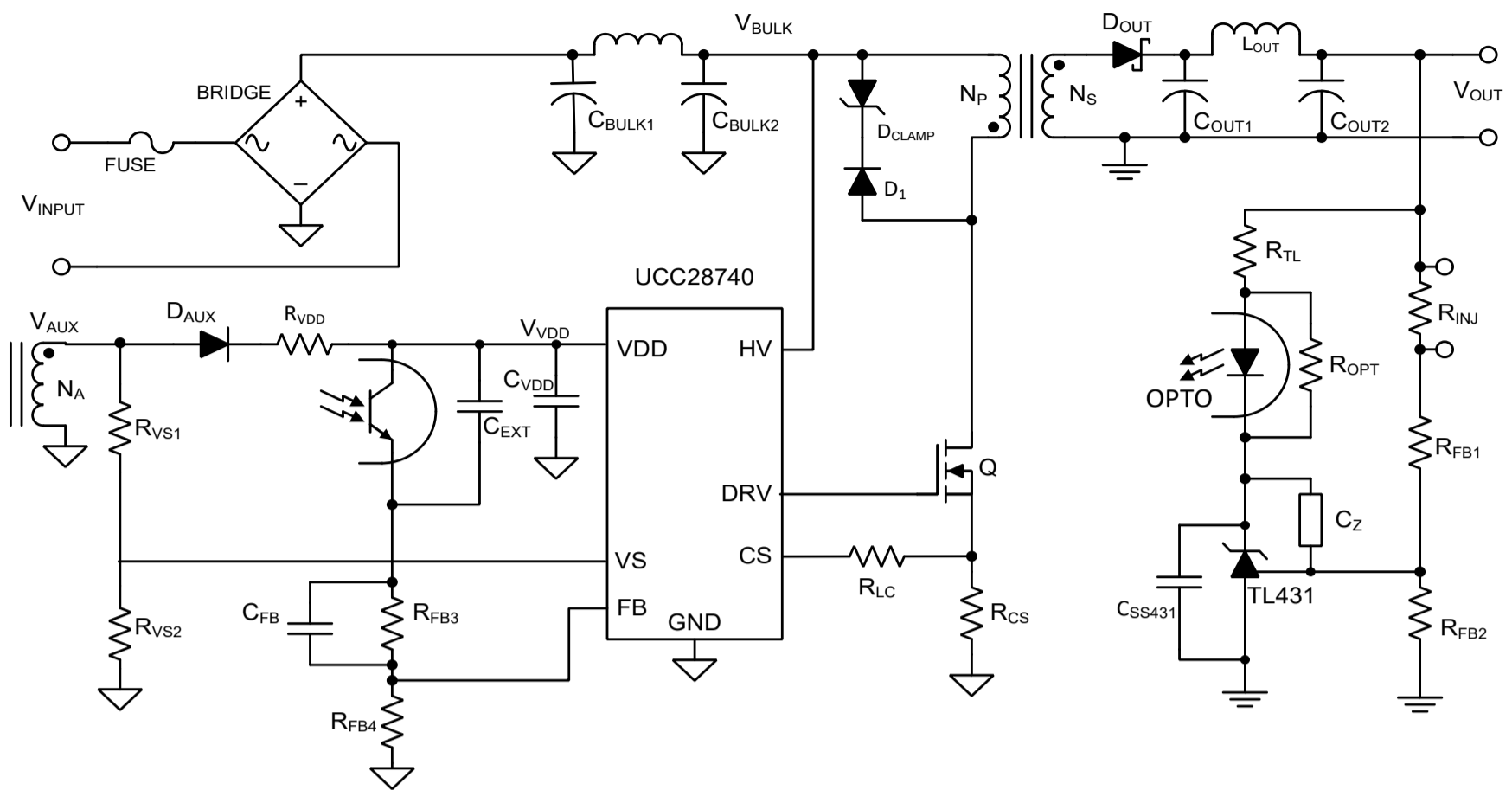

RECOMMENDED BILL OF MATERIALS

Reference Designator	Description/Comments
BRIDGE RECTIFIER	Minimum DC Blocking Voltage: 400 V
	Minimum Current Rating: 1.318 A
	Power Dissipation: 2998.697 mW
$C_{BULKtotal} = C_{BULK1} + C_{BULK2}$	Type: Aluminum Electrolytic
	Value: 256 μ F Total Capacitance
	Minimum Voltage Rating: 400 V
	Minimum Ripple Current Rating: 1499.349 mA
C_{EXT}	Type: Ceramic
	Value: 0 μ F $\pm 10\%$
	Minimum Voltage Rating: 50 V
C_{FB}	Type: Ceramic
	Value: 0.047 μ F $\pm 10\%$
	Minimum Voltage Rating: 10 V
$C_{OUTtotal} = C_{OUT1} + C_{OUT2}$	Type: Aluminum Electrolytic
	Minimum Value: 680 μ F Total Capacitance
	Minimum Voltage Rating: 80.000 V
	Minimum Ripple Current Rating: 1.205 A
	Maximum ESR Rating: 7.971 m Ω
C_{SS431}	Type: Ceramic
	Value: 1 μ F $\pm 10\%$
	Minimum Voltage Rating: 10 V
C_{VDD}	Type: Ceramic
	Minimum Value: 22 μ F $\pm 10\%$
	Voltage Rating: 50 V
C_Z	Type: Ceramic
	Value: 22000 pF $\pm 10\%$
	Voltage Rating: 10 V
D_{AUX}	Type: Switching
	Minimum Required Blocking Voltage: 58.834 V
	Minimum Rated Current: 250 mA

D_{CLAMP}	Type:	Transient Voltage Suppressor	
	Voltage:	178.499 V	
	Power Rating:	600.000 W	
D_{OUT}	Type:	Schottky	
	Minimum Blocking Voltage Rating:	487.961 V	
	Minimum Average Current Rating:	1.417 A	
	Power Dissipation:	1.104 W	
D₁	Type:	Ultra Fast	
	Voltage Rating:	1000 V	
	Current Rating:	1 A	
FUSE	Type:	Slow Blow	
	Minimum Voltage Rating:	265 VAC	
	Minimum Peak Current Rating:	4.306 A	
OPTO-COUPLER	CTR _{min} :	50 %	
Q	Minimum V _{DS} Voltage Rating:	700 V	
	Minimum Continuous Current Rating:	11.543 A	
	Minimum Repetitive Peak Current Rating:	29.014 A	
	Power Dissipation:	1.567 W	
R_{CS}	Value:	0.282 Ω	±1%
	Power Dissipation:	335.406 mW	
	Type:	Low Inductance	
R_{FB1}	Value:	9.5 kΩ	±1%
	Power Rating:	1/10 W	
R_{FB2}	Value:	51 kΩ	±1%
	Power Rating:	1/10 W	
R_{FB3}	Value:	100 kΩ	±1%
	Power Rating:	1/10 W	
R_{FB4}	Value:	22 kΩ	±1%
	Power Rating:	1/10 W	
R_{INJ}	Value:	20 Ω	±1%
	Power Rating:	1/10 W	
R_{LC}	Value:	1.3 kΩ	±1%
	Power Rating:	1/10 W	
R_{OPT}	Value:	1 kΩ	±1%
	Power Rating:	1/10 W	
R_{TL}	Value:	1.5 kΩ	±1%
	Power Rating:	1/10 W	
R_{VDD}	Value:	2 to 50 Ω	As Needed for Voltage Spike Smoothing
	Power Rating:	1/10 to 1/2 W	
R_{VS1}	Value:	40 kΩ	±1%
	Power Rating:	1/10 W	
R_{VS2}	Value:	26 kΩ	±1%
	Power Rating:	1/10 W	
SHUNT REGULATOR	Voltage Reference:	80 V	
TRANSFORMER	Primary Inductance:	192.5 μH	
	Primary to Secondary Turns Ratio:	1.373	N _{PS}
	Primary to Auxiliary Turns Ratio:	10.000	N _{PA}
	Peak Primary Current:	2.741 A	

Primary RMS Current:	1.091 A
Peak Secondary Current:	3.764 A
Secondary RMS Current:	1.417 A
Maximum Switching Frequency:	89.995 kHz

UCC28740 DESIGN CALCULATIONS

The Values Entered by the User on the DESIGN INPUT Page are Used in the Design Calculations

INPUT				
Input Voltage Type	AC or DC:	AC	User Input Values From Design Input Page	
Minimum Input Voltage	$V_{INPUTmin} =$	85 VAC		
Maximum Input Voltage	$V_{INPUTmax} =$	265 VAC		
Nominal Input Voltage	$V_{INPUTnom} =$	220 VAC		
Minimum Line Frequency	$f_{LINEmin} =$	47 Hz		
Minimum Input Voltage for Start-Up	$V_{INPUTrun} =$	80 VAC		
Minimum Peak Bulk Input Voltage	$V_{BULKmin} =$	120.208 V	User Input Values From Design Input Page	
Maximum Peak Bulk Input Voltage	$V_{BULKmax} =$	374.767 V		
Nominal Peak Bulk Input Voltage	$V_{BULKnom} =$	311.127 V		
Turn-On Peak Bulk Input Voltage	$V_{BULKstartUp} =$	113.137 V		
Line Cycle Period	$t_{LINE} =$	21.277 ms		
OUTPUT				
Regulated Output Voltage, Constant Voltage Mode	$V_{OUT_CV} =$	80 V		
Full Load Rated Output Current	$I_{OUT} =$	0.6 A		
Target Constant Current Mode Output Load Threshold	$I_{OCC_target} =$	0.7 A		
Target Minimum Output Voltage During Constant Current Regulation	$V_{OUT_CC} =$	78 V		
Allowable Output Voltage Drop During Load-Step Transient in Constant Voltage Mode	$V_{OUT\Delta} =$	5 V		
Maximum Peak to Peak Output Voltage Ripple	$V_{RIPPLE} =$	30 mV		
Required Positive Load Step Transient Current	$I_{TRAN} =$	0.7 A		
Maximum Allowable Response Time to Load Step Transient	$t_{RESP} =$	20 ms		
Output Over Voltage Protection	$V_{OUT_OVP} =$	85 V		
Maximum Stand By Power Dissipation	$P_{SBtarget} =$	50 mW		
Estimated Efficiency	$\eta =$	0.850		
Output Power	$P_{OUT} =$	56.000 W		
Estimated Input Power	$P_{IN} =$	65.882 W		

COMPONENT PARAMETER CALCULATIONS

INPUT CAPACITOR, C_{BULK}			
Recommended Input Bulk Capacitance	$C_{BULKrecommended} =$	256.01 μ F	User Input
Actual Input Bulk Capacitance	$C_{BULKactual} =$	256.000 μ F	
Input Capacitor Value Used in Calculations	$C_{BULK} =$	256.000 μ F	
Minimum Valley Voltage on Input Bulk Capacitors	$V_{BULKvalley} =$	99.999 V	
Minimum Input Capacitor Ripple Current Rating	$I_{CINripple} =$	1499.349 mA	
Minimum Input Capacitor Voltage Rating	$V_{Cin} =$	400 V	

INPUT FUSE			
Voltage Rating	$V_{FUSE} =$	265 VAC	
Peak Input Current	$I_{INpeak} =$	4.306 A	

BRIDGE RECTIFIER			
Voltage Rating	$V_{BRIDGE_minrating} =$	400.000 V	User Input
Current Rating	$I_{BRIDGE_minrating} =$	1.318 A	
Forward Voltage Drop	$V_{F_BRIDGE} =$	1.000 V	
Full Load Power Dissipation of Bridge Rectifier	$P_{BRIDGE} =$	2998.697 mW	

TRANSFORMER TURNS-RATIO, N_{PS}			
Demagnetizing Duty Cycle	$D_{DEMAG_CC} =$	0.425	Device Parameter
Amplitude Modulation Control Ratio	$K_{AMnom} =$	4	Device Parameter
Maximum Desired Switching Frequency	$f_{max_target} =$	100.000 kHz	User Input
Desired Switching Period	$t_{SW_target} =$	10.000 μ s	
Resonant Frequency During DCM Dead Time	$f_{RES} =$	0.500 MHz	
Time to First Resonant Valley	$t_{RES} =$	1.000 μ s	

Estimated Maximum Duty Cycle	$D_{max_target} =$	0.475	
Ideal Primary to Secondary Turns Ratio	$N_{PSideal} =$	1.3734	Ideal N_{PS}
Actual Primary to Secondary Turns Ratio	$N_{PSactual} =$	1.373	User Input
Primary to Secondary Turns Ratio Used in Calculations	$N_{PS} =$	1.373	
Actual Flyback Voltage	$V_{FLYBACK} =$	111.735V	
Allowable Leakage Inductance Voltage Spike	$V_{LEAKAGE} =$	213.499V	
Estimated Maximum On-Time	$t_{ONestimated} =$	4.749 μ s	
Estimated Transformer Efficiency	$\eta_{XFMR} =$	0.9	

CURRENT SENSE RESISTOR, R_{CS} , PEAK PRIMARY CURRENT, I_{PP}			
Constant Current Regulation Factor, Minimum	$V_{CCR_min} =$	318mV	Device Parameter
Constant Current Regulation Factor, Nominal	$V_{CCR_nom} =$	330mV	Device Parameter
Constant Current Regulation Factor, Maximum	$V_{CCR_max} =$	343mV	Device Parameter
Initial estimate for L_p	$L_{p_estimate} =$	219.921 μ H	
Recommended Current Sense Resistor Value	$R_{CSrecommended} =$	0.302 Ω	
Actual Current Sense Resistor Used	$R_{CSactual} =$	0.282 Ω	User Input
Current Sense Resistor Value Used in Calculation	$R_{CS} =$	0.282 Ω	
Power Dissipation of R_{CS}	$P_{Rcs} =$	335.406mW	
Maximum Current Sense Threshold Voltage, Minimum	$V_{CSTmax_min} =$	738mV	Device Parameter
Maximum Current Sense Threshold Voltage, Nominal	$V_{CSTmax_nom} =$	773mV	Device Parameter
Maximum Current Sense Threshold Voltage, Maximum	$V_{CSTmax_max} =$	810mV	Device Parameter
Peak Primary Current, Minimum, Full Load	$I_{PPmin} =$	2.617A	
Peak Primary Current, Nominal, Full Load	$I_{PPnom} =$	2.741A	
Peak Primary Current, Maximum, Full Load	$I_{PPmax} =$	2.872A	
Actual Output Current During Constant Current Mode	$I_{OCC_actual} =$	0.800A	
Peak Primary Current During Light Load, FM Mode	$I_{PP_FM} =$	0.685A	
Worst Case Peak Primary Current	$I_{PP_WC} =$	2.901A	Assumes -1% R_{CS} and V_{CSTmax_max}
Maximum Output Current During Constant Current Mode	$I_{OCCmax} =$	0.847A	Worst Case Estimate

TRANSFORMER PRIMARY INDUCTANCE, L_p			
Calculated L_p to meet f_{max_target} with chosen R_{CS}	$L_{Pcalc} =$	192.488 μ H	
Recommended Primary Inductance to meet t_{CSLEB} with chosen R_{CS}	$L_{Precommended} =$	192.488 μ H	Ideal L_p
Actual Primary Inductance	$L_{Pactual} =$	192.500 μ H	User Input
Primary Inductance Used in Calculations	$L_p =$	192.500 μ H	
Actual Maximum Nominal Switching Frequency	$f_{max} =$	89.995kHz	
Actual Switching Period	$t_{SWactual} =$	11.112 μ s	
Actual Maximum On-Time	$t_{ONmax} =$	5.277 μ s	
Maximum Duty Cycle	$D_{MAX} =$	0.475	
Demagnetization Time	$t_{DEMAG} =$	4.723 μ s	
Primary RMS Current	$I_{PRI_RMS} =$	1.091A	
Secondary Peak Current	$I_{SPmax} =$	3.764A	
Secondary RMS Current	$I_{SEC_RMS} =$	1.417A	
VDD Under Voltage Lock Out (UVLO) Voltage, Maximum	$VDD_{OFF_max} =$	8.150V	Device Parameter
VDD Under Voltage Lock Out (UVLO) Voltage, Minimum	$VDD_{OFF_min} =$	7.350V	Device Parameter
Recommended Auxiliary to Secondary Turns Ratio	$N_{ASrecommended} =$	0.113	
Recommended Primary to Auxiliary Turns Ratio	$N_{PArecommended} =$	12.178	
Actual Primary to Auxiliary Turns Ratio	$N_{PAactual} =$	10.000	User Input
Primary to Auxiliary Turns Ratio Used in Calculations	$N_{PA} =$	10.000	
Nominal VDD Voltage	VDD =	10.373V	
Actual Auxiliary to Secondary Turns Ratio	$N_{AS} =$	0.137	
Minimum On-Time, t_{CSLEB}	$t_{ONmin(limit)} =$	280.000ns	
Actual Minimum On-Time	$t_{ONmin(actual)} =$	351.998ns	
Minimum Demagnetizing Time	$t_{DEMAGmin} =$	1.181 μ s	
Minimum Output Voltage During Constant Current Mode	$V_{OUT_ccmin} =$	57.979V	

MOSFET, Q			
Required Drain to Source Voltage Rating, $V_{DSrated} =$	$V_{DSmin_rating} =$	632.452V	
MOSFET Rated Drain to Source Voltage	$V_{DS} =$	700.000V	

Output Capacitance of Selected MOSFET	$C_{OSS} =$	100	pF	User Input Values From Design Input Page
Drain to Source On-Resistance of Selected MOSFET	$R_{DSon} =$	0.450	Ω	
MOSFET Fall Time	$t_f =$	12.000	ns	
MOSFET Turn Off Delay Time	$t_{doff} =$	39	ns	
MOSFET Total Gate Charge	$Q_g =$	14.000	nC	
Actual Resonant Frequency During DCM Dead Time	$f_{RES_actual} =$	0.811	MHz	
Actual Estimated Time to First Resonant Valley	$t_{RES_actual} =$	0.616	μ s	
Valley Switching Achieved?	YES or NO	YES		
MOSFET V_{DS} Derating	$V_{DSderated} =$	0.904		
MOSFET Continuous Current Rating	$I_{DRAIN} =$	11.543	A	
MOSFET Pulsed Current Rating	$I_{PULSED} =$	29.014	A	
Estimated MOSFET Conduction Losses	$P_{FETconduction} =$	0.535	W	
Estimated MOSFET Switching Losses	$P_{FETswitching} =$	1.031	W	
Total Estimated MOSFET Power Loss	$P_{FET} =$	1.567	W	
Recommended Clamping Voltage on Drain	$V_{DRAINclamp} =$	178.499	V	

OUTPUT DIODE, D_{OUT}				
Forward Voltage Drop of Output Rectifier, $V_F =$	$V_F =$	1.380	V	User Input
Minimum Required Blocking Voltage Rating	$V_{DOUT_blocking} =$	487.961	V	
Required Minimum Average Rectified Output Current	$I_{Dout} =$	1.417	A	
Power Dissipation of D_{OUT}	$P_{Dout} =$	1.104	W	

AUXILIARY WINDING DIODE, D_{AUX}				
Auxiliary Rectifier Forward Voltage Drop	$V_{FA} =$	0.800	V	User Input
Minimum Required Blocking Voltage Rating	$V_{DBIAS_blocking} =$	58.834	V	

OUTPUT INDUCTOR, L_{OUT}				
DCR of Output Inductor	$DCR_{Lout} =$	0	m Ω	User Input

OUTPUT CAPACITOR, C_{OUT}				
Minimum Required C_{OUT} Without Opto-Coupled FeedBack	$C_{OUT_no_opto} =$	2800.000	μ F	The importance of using opto feedback should be noted here!
Recommended Minimum Required Output Capacitor With Opto-Coupled FeedBack	$C_{OUTrecommended} =$	680.000	μ F	
Actual Output Capacitance Used	$C_{OUTactual} =$	680.000	μ F	User Input
C_{OUT} Used in Calculations	$C_{OUT} =$	680.000	μ F	
Required Minimum Ripple Current Rating	$I_{COUTrms} =$	1.205	A	
Recommended Maximum ESR	$ESR_{Coutrecommended} =$	7.971	m Ω	
Actual ESR of C_{OUT} Used	$ESR_{Coutactual} =$	50.000	m Ω	User Input
ESR Used in Calculations	$ESR_{Cout} =$	50.000	m Ω	
Resultant Output Voltage Peak to Peak Ripple	$V_{OUTripple} =$	188.281	mV	

VOLTAGE SENSE DIVIDER, R_{VS1} R_{VS2}				
VS Line Sense Run Current, Minimum	$I_{VSLrun_min} =$	190	μ A	Device Parameter
VS Line Sense Run Current, Nominal	$I_{VSLrun_nom} =$	225	μ A	Device Parameter
VS Line Sense Run Current, Maximum	$I_{VSLrun_max} =$	275	μ A	Device Parameter
VS Line Sense Stop Current, Minimum	$I_{VSLstop_min} =$	70	μ A	Device Parameter
VS Line Sense Stop Current, Nominal	$I_{VSLstop_nom} =$	80	μ A	Device Parameter
VS Line Sense Stop Current, Maximum	$I_{VSLstop_max} =$	100	μ A	Device Parameter
Recommended Resistor Value for Minimum Start Up Line Voltage	$R_{VS1recommended} =$	40.200	k Ω	
Actual Resistor Value Used for Minimum Start Up Line Voltage	$R_{VS1actual} =$	40	k Ω	User Input
R_{VS1} Value Used in Calculations	$R_{VS1} =$	40	k Ω	
Resultant Turn On Voltage, Minimum	$V_{TURNONmin} =$	53.740	VAC	
Resultant Turn On Voltage, Nominal	$V_{TURNONnom} =$	63.640	VAC	
Resultant Turn On Voltage, Maximum	$V_{TURNONmax} =$	77.782	VAC	
Resultant Input Brown Out Voltage, Minimum	$V_{BROWNOUTmin} =$	34.089	VAC	
Resultant Input Brown Out Voltage, Nominal	$V_{BROWNOUTnom} =$	36.917	VAC	
Resultant Input Brown Out Voltage, Maximum	$V_{BROWNOUTmax} =$	42.574	VAC	
Internal VS Over Voltage Threshold, Minimum	$V_{OVmin} =$	4.52	V	Device Parameter
Internal VS Over Voltage Threshold, Nominal	$V_{OVnom} =$	4.600	V	Device Parameter
Internal VS Over Voltage Threshold, Maximum	$V_{OVmax} =$	4.710	V	Device Parameter
Recommended Resistor Value for Desired Output Over Voltage Limit	$R_{recommended} =$	26	100k Ω	

Recommended Resistor Value for Desired Output Over Voltage Limit	$R_{VS2\text{recommended}}$	26.000kΩ	User Input
Actual Resistor Value Used for Desired Output Over Voltage Limit	$R_{VS2\text{actual}} =$	26.000kΩ	User Input
R_{VS2} Used in Calculations	$R_{VS2} =$	26.000kΩ	
Resultant Output Over Voltage Threshold, Minimum	$V_{\text{OUT_OVPmin}} =$	84.948V	
Resultant Output Over Voltage Threshold, Nominal	$V_{\text{OUT_OVPnom}} =$	86.427V	Actual Output Over Voltage
Resultant Output Over Voltage Threshold, Maximum	$V_{\text{OUT_OVPmax}} =$	88.461V	

LINE COMPENSATION, R_{LC}			
Line Compensation Current Ratio, Nominal	$K_{LC\text{nom}} =$	25 A/A	Device Parameter
Total Estimated Current Sense Delay	$t_{\text{DELAY}} =$	89 ns	
Recommended Resistor Value for Line Compensation	$R_{LC\text{recommended}} =$	1.330kΩ	
Actual Resistor Value Used for Line Compensation	$R_{LC\text{actual}} =$	1.300kΩ	User Input
R_{LC} Used in Calculations	$R_{LC} =$	1.300kΩ	
Result of R_{LC} selection	Output Constant Current will have minimal deviation over input line voltage range.		

VDD CAPACITOR, C_{VDD}			
Device Supply Current During Run Mode, Maximum	$I_{\text{RUNmax}} =$	2.65 mA	Device Parameter
VDD _{ON} Voltage, Maximum	$V_{\text{DDONmax}} =$	23 V	Device Parameter
VDD _{OFF} Voltage, Maximum	$V_{\text{DDOFFmax}} =$	8.15 V	Device Parameter
Estimated Minimum Switching Frequency at No-Load	$f_{\text{SWmin}} =$	0.885 kHz	
Estimated Over Voltage Charge Duration	$t_{\text{OV}} =$	20.000 ms	
Minimum VDD Capacitor for Start UP	$C_{\text{VDD1}} =$	22.000 μF	
Minimum VDD Capacitor for Load Transient	$C_{\text{VDD2}} =$	15.000 μF	
Minimum VDD Capacitor for Target Ripple on VDD	$C_{\text{VDD3}} =$	3.300 μF	
Recommended Capacitor on VDD	$C_{\text{VDDrecommended}} =$	22.000 μF	

OPTO-COUPLED FEEDBACK			
Reference Voltage of TL431 Shunt Regulator	$V_{\text{REF431}} =$	80 V	User Input
Shunt Regulator Reference Input Current, Maximum	$I_{\text{REF431}} =$	110 μA	User Input
Recommended Bottom Resistor Value for Output Voltage Set Point	$R_{\text{FB2recommended}} =$	51.1 kΩ	
Actual Bottom Resistor Value Used for Output Voltage Set Point	$R_{\text{FB2actual}} =$	51 kΩ	User Input
R_{FB2} Used in Calculations	$R_{\text{FB2}} =$	51 kΩ	
Recommended Top Resistor Value for Output Voltage Set Point	$R_{\text{FB1recommended}} =$	Err:502 kΩ	
Actual Top Resistor Value Used for Output Voltage Set Point	$R_{\text{FB1actual}} =$	9.5 kΩ	User Input
R_{FB1} Used in Calculations	$R_{\text{FB1}} =$	9.52 kΩ	
Noise Injection Resistor For Loop Analysis	$R_{\text{NI}} =$	20 Ω	May be changed by User here
Resultant Nominal Constant Voltage Output Voltage	$V_{\text{OUT_CV}} =$	94.933 V	
Minimum Current Transfer Ratio of Selected Opto-Coupler	$\text{CTR}_{\text{min}} =$	50 %	User Input
Response Fall Time of Opto-Coupler	$t_{\text{f_opto}} =$	3 μs	User Input
R_{L} of Specified Opto-Coupler Fall Time	$R_{\text{L_opto}} =$	100 Ω	User Input
Cut-Off Frequency of Opto-Coupler	$f_{\text{c_opto}} =$	80 kHz	User Input
Input Forward Voltage of Opto-Coupler	$V_{\text{F_opto}} =$	1.4 V	User Input
Equivalent Opto-Coupler Output Capacitance	$C_{\text{OPTO}} =$	4.775 nF	
Equivalent Internal UCC28740 Dynamic Resistance	$R_{\text{EQU}} =$	40 kΩ	
Recommended Value for External Capacitor on Opto-Coupler	$C_{\text{EXTrecommended}} =$	0 μF	
Actual Value of External Capacitor on Opto-Coupler Used	$C_{\text{EXTactual}} =$	0 μF	User Input
C_{EXT} Used in Calculations	$C_{\text{EXT}} =$	0 μF	
Recommended C_{FB}	$C_{\text{FBrecommended}} =$	0.047 μF	
Actual C_{FB} Used	$C_{\text{FBactual}} =$	0.047 μF	User Input
C_{FB} Used in Calculations	$C_{\text{FB}} =$	0.047	
Recommended Value For R_{FB4}	$R_{\text{FB4recommended}} =$	22 kΩ	
Actual Value for R_{FB4} Used	$R_{\text{FB4actual}} =$	22 kΩ	User Input
R_{FB4} Used in Calculations	$R_{\text{FB4}} =$	22 kΩ	
Opto-Coupler Emitter Current to FB Pin Current Gain	$G_{\text{FB1}} =$	0.355	
FB Pin Current to Control Law Voltage Gain, Full Load	$G_{\text{FB2}} =$	-192 kΩ	
Control Law Voltage to Power Stage Modulation Gain, FM Mode	$K_{\text{FM}} =$	50.4 kHz/V	
Power Stage Modulation (FM) to Average Current Gain	$G_{\text{P4}} =$	7.778 μC	

Recommended Value for Shunt Regulator Bias Resistor	$R_{TL\text{recommended}} =$	1.5 k Ω	
Actual Value of Shunt Regulator Bias Resistor Used	$R_{TL\text{actual}} =$	1.5 k Ω	User Input
R_{TL} Used in Calculations	$R_{TL} =$	1.5 k Ω	
Recommended Value for Compensation Capacitor	$C_{z\text{recommended}} =$	22000 pF	
Actual Value Used C_z	$C_{z\text{actual}} =$	22000 pF	User Input
C_z Used in Calculations	$C_z =$	22000 pF	

