

# MCU

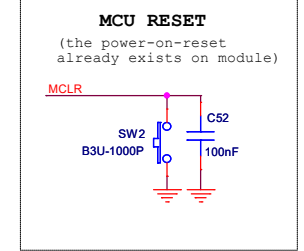

HFINTOSC:1-64MHz internal oscillator  
LFINTOSC:32 kHz internal oscillator

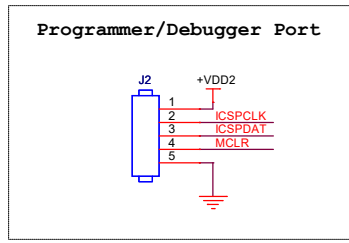

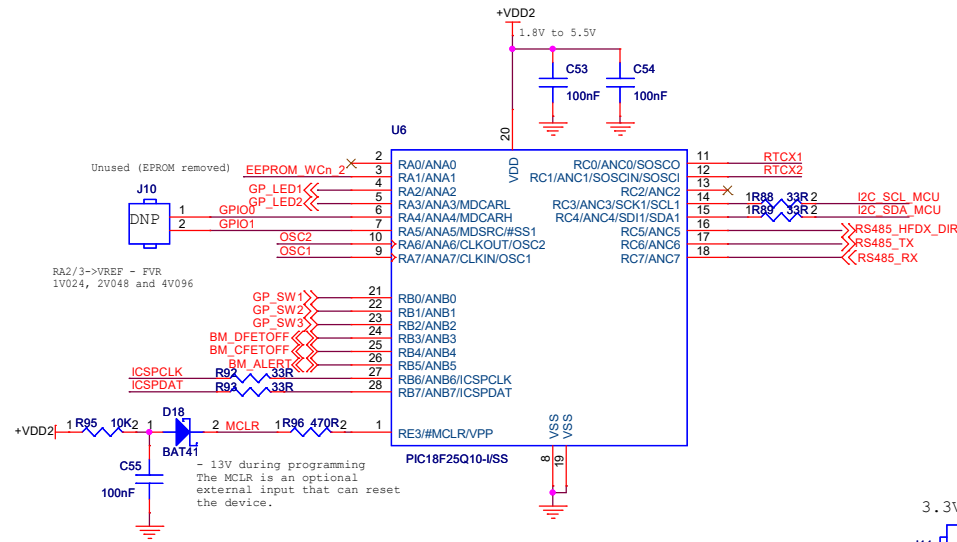
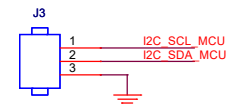
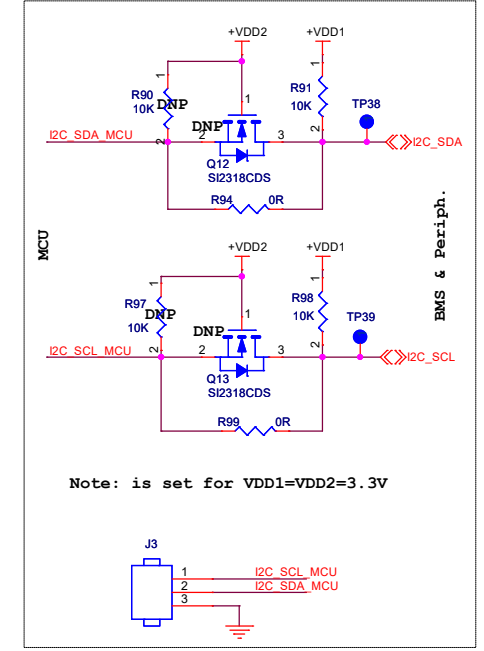
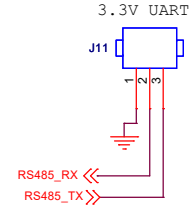
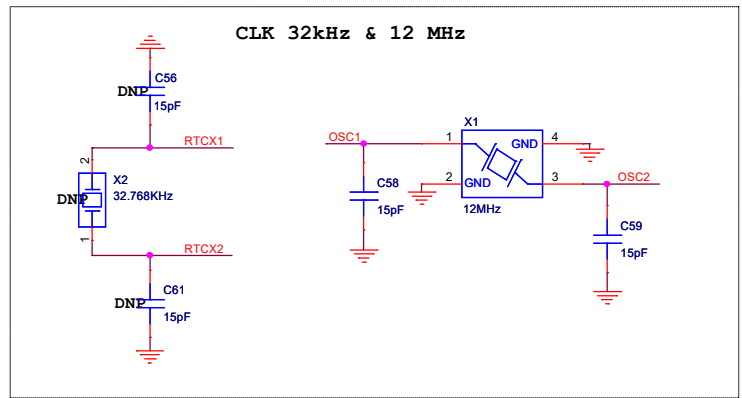

# BMS

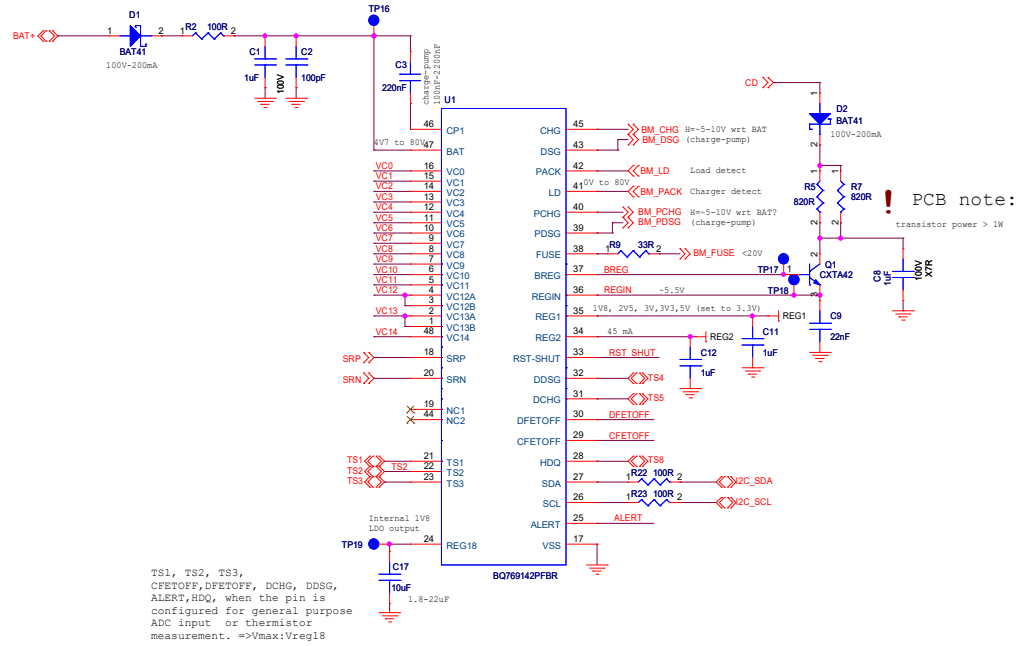
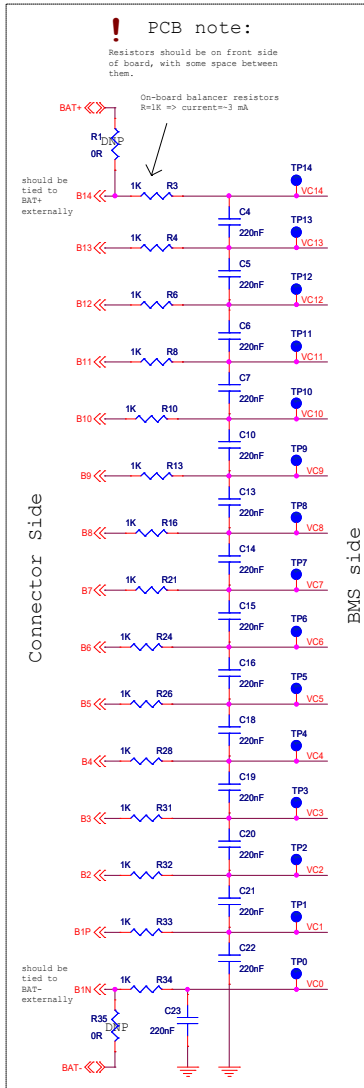

PCB note:  
transistor power > 1W

