

To TI Support:

Below please find the “schematic” and PCB layout you requested. Unfortunately, this design was performed more than 20 years ago, and the schematic entry and PCB layout were both performed using tools that are now lost to the ages. As a result, the full schematic is no longer available. Likewise, for the PCB artwork, a print of the resulting Gerber data is all that remains.

I’ve drawn the portion of the “schematic” most pertinent to the current discussion by “pencil in” the values for the various components using the block diagram from your datasheet. This portion of the design was ostensibly copied from your example in the data sheet, followed by a DPDT to select output polarity and a resettable fuse for short circuit protection. This portion occupies the upper half of the attached PCB drawing.

The remainder of the design (not shown here), occupying the lower half of the board, consists of a digital portion to communicate with the module remotely, to set the output voltage (by adjusting the value of R1) and control the polarity select relay. That section is completely optically isolated from the regulator section, so hopefully is not pertinent to this discussion. If you do need it, I can reproduce the full schematic, but that will take some time. If it helps to visualize things, I’ve also included photos of an assembled board. I apologize for the incompleteness of what I’m able to provide.

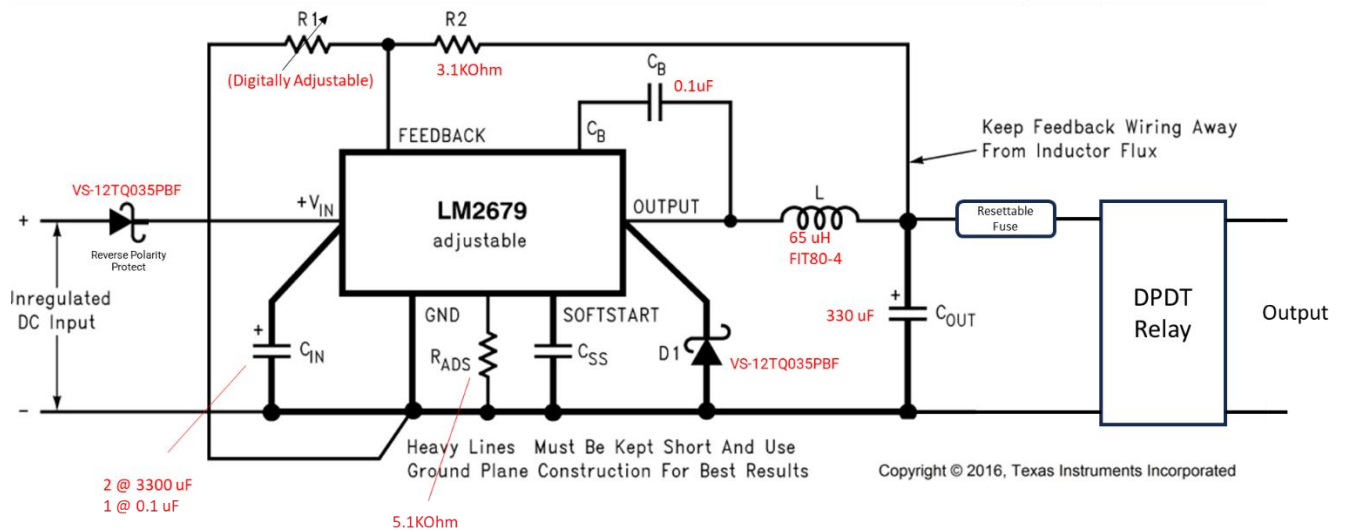

Component Side:

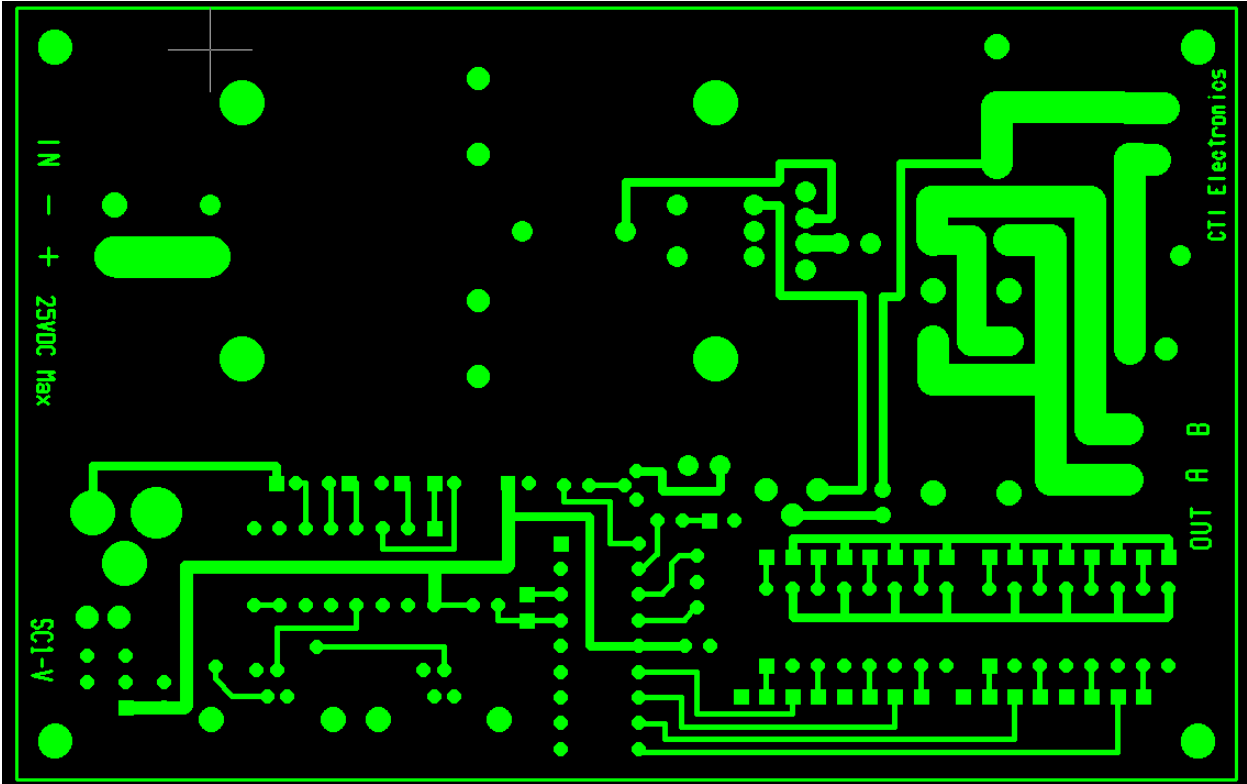

Solder Side:

