

MCU, LED, AGX, 电源接口, 电机预充+控制, 小功率DCDC, 大功率DCDC, 充电端口, 法拉电容充电, PWM, CAN隔离电源, 温度监测

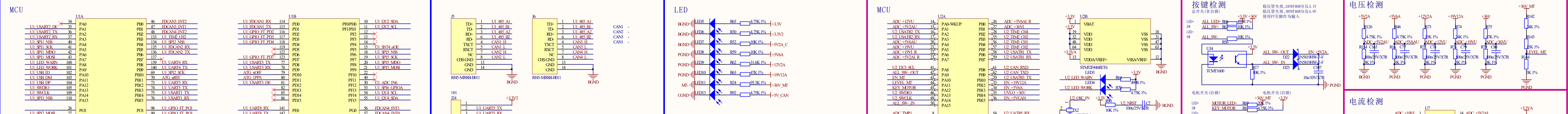

MCU, LED, AGX, 电源接口, 电机预充+控制, 小功率DCDC, 大功率DCDC, 充电端口, 法拉电容充电, PWM, CAN隔离电源, 温度监测

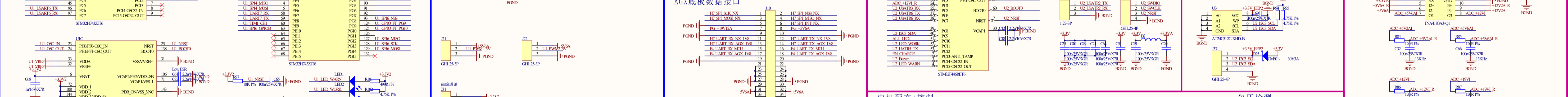

MCU, LED, AGX, 电源接口, 电机预充+控制, 小功率DCDC, 大功率DCDC, 充电端口, 法拉电容充电, PWM, CAN隔离电源, 温度监测

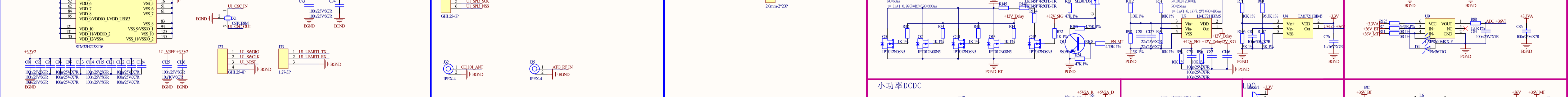

MCU, LED, AGX, 电源接口, 电机预充+控制, 小功率DCDC, 大功率DCDC, 充电端口, 法拉电容充电, PWM, CAN隔离电源, 温度监测

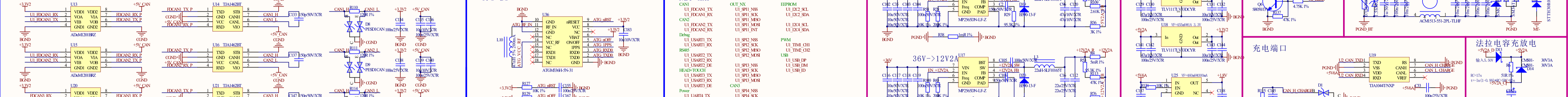

MCU, LED, AGX, 电源接口, 电机预充+控制, 小功率DCDC, 大功率DCDC, 充电端口, 法拉电容充电, PWM, CAN隔离电源, 温度监测

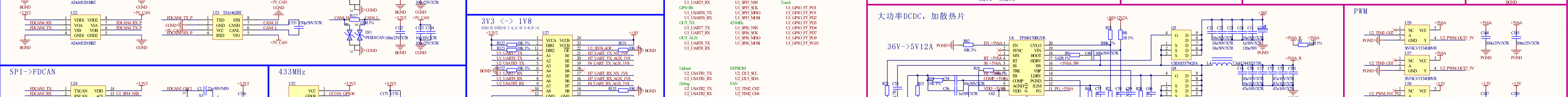

MCU, LED, AGX, 电源接口, 电机预充+控制, 小功率DCDC, 大功率DCDC, 充电端口, 法拉电容充电, PWM, CAN隔离电源, 温度监测



MCU, LED, AGX, 电源接口, 电机预充+控制, 小功率DCDC, 大功率DCDC, 充电端口, 法拉电容充电, PWM, CAN隔离电源, 温度监测

