

Multi-function Pins for External Communication

- CFETOFF / SPI_CS
- HDQ / SPI_MOSI
- SDA / SPI_MISO
- SCL / SPI_SCLK
- ALERT / HDQ

Pull-up / pull-down selection

uController interface type selection

External I2C Connection

External SPI Connections / HDQ

Cell Simulator - Populate shunts to use cell simulator if not connecting a battery.

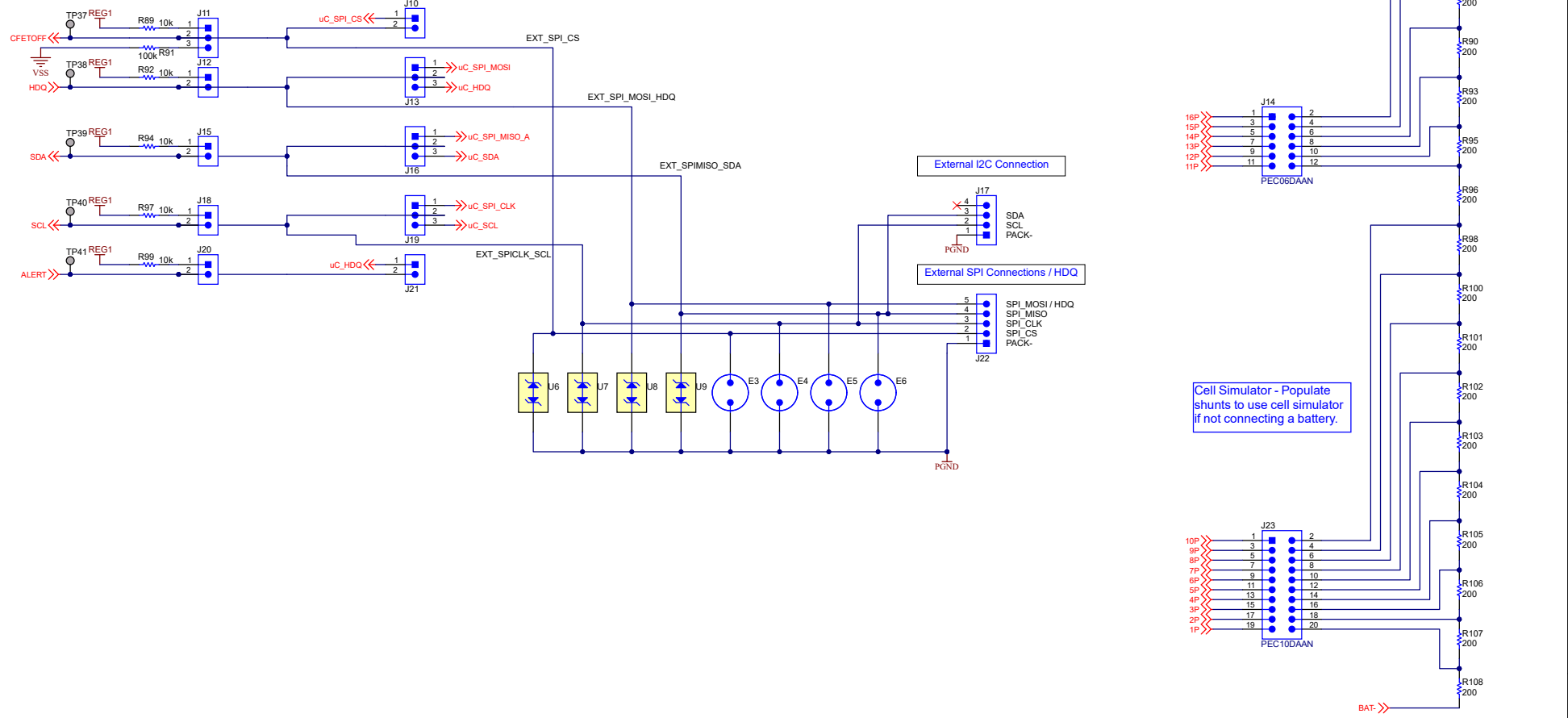

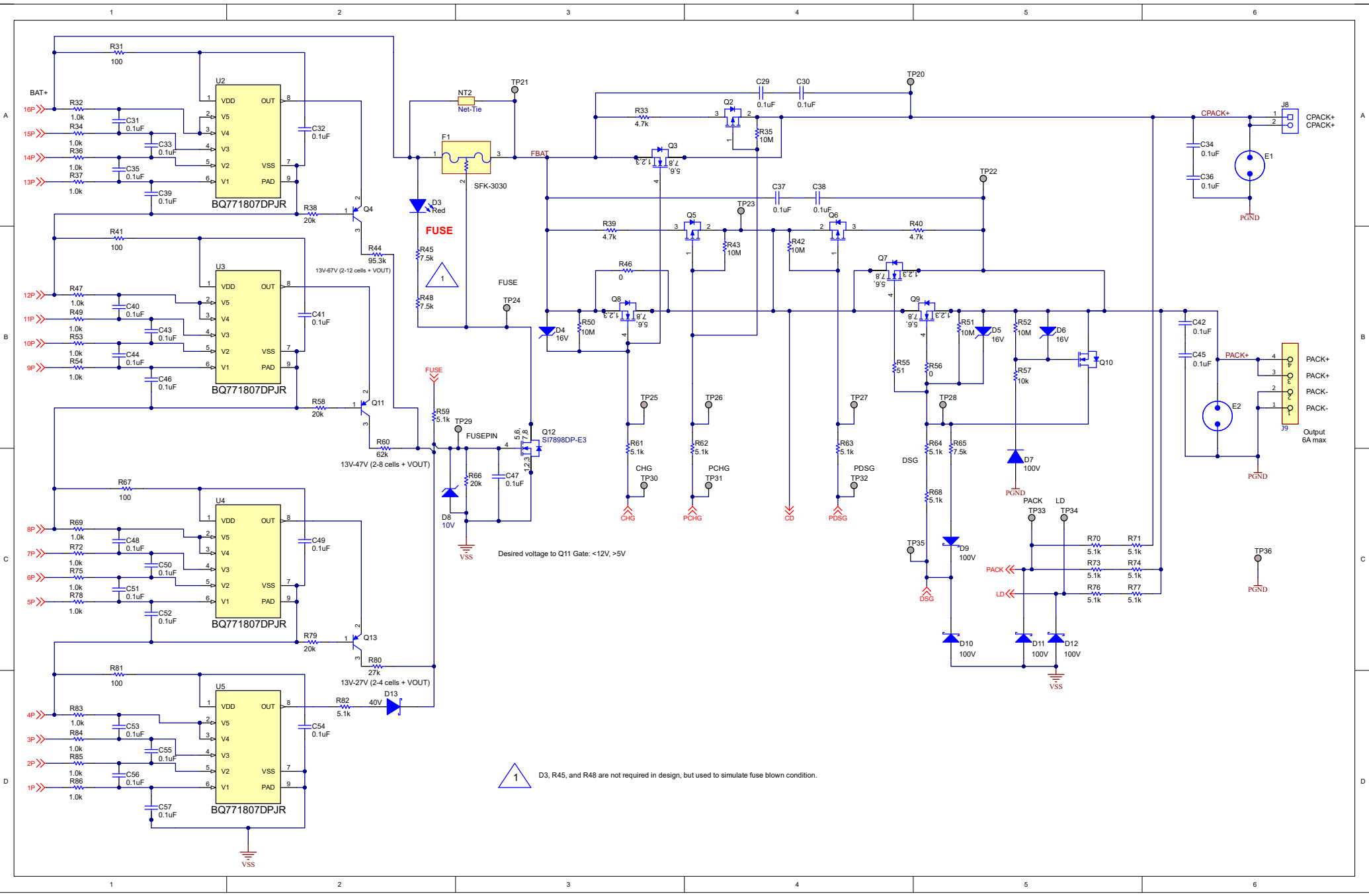

1 D3, R45, and R48 are not required in design, but used to simulate fuse blown condition.

