

BATTERY CHARGING CIRCUIT

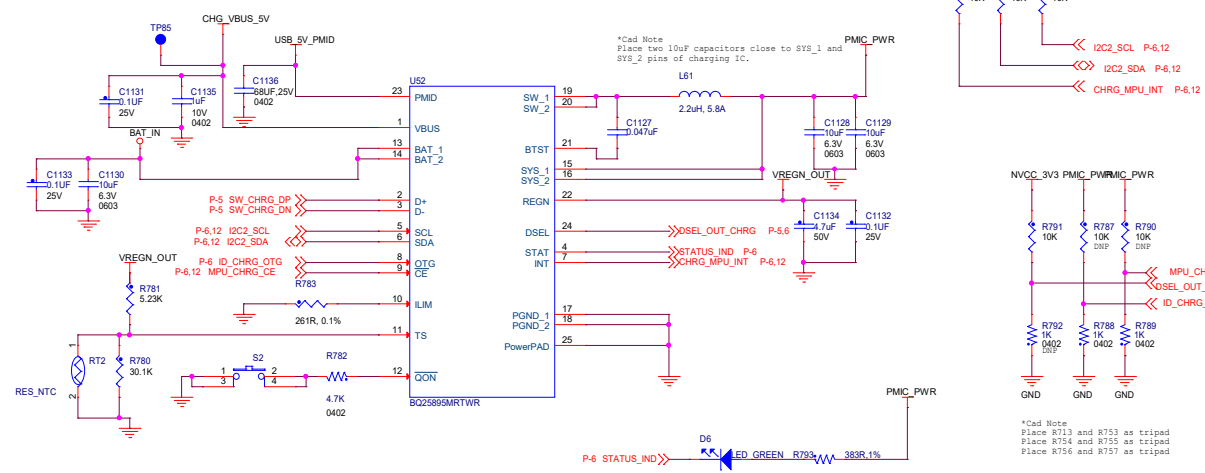

USB HOST AND OTG POWER

