

OUTPUT CONNECTOR WILL HAVE:
ETHERNET - 2 PAIRS
USB OTG - WITH 2 CC LINES, ID LINE?
5V USB BIDIRECTIONAL POWER
28V POWER INPUT
1 CONTACT CLOSURE INPUT - PULLUP TO 3.3V INTERNAL, CONNECTOR TO GPIO INTERRUPT ON ESP32
USB MUST BE ABLE TO CONNECT TO USB-C, USB-A, BE A HOST AND BE A DEVICE

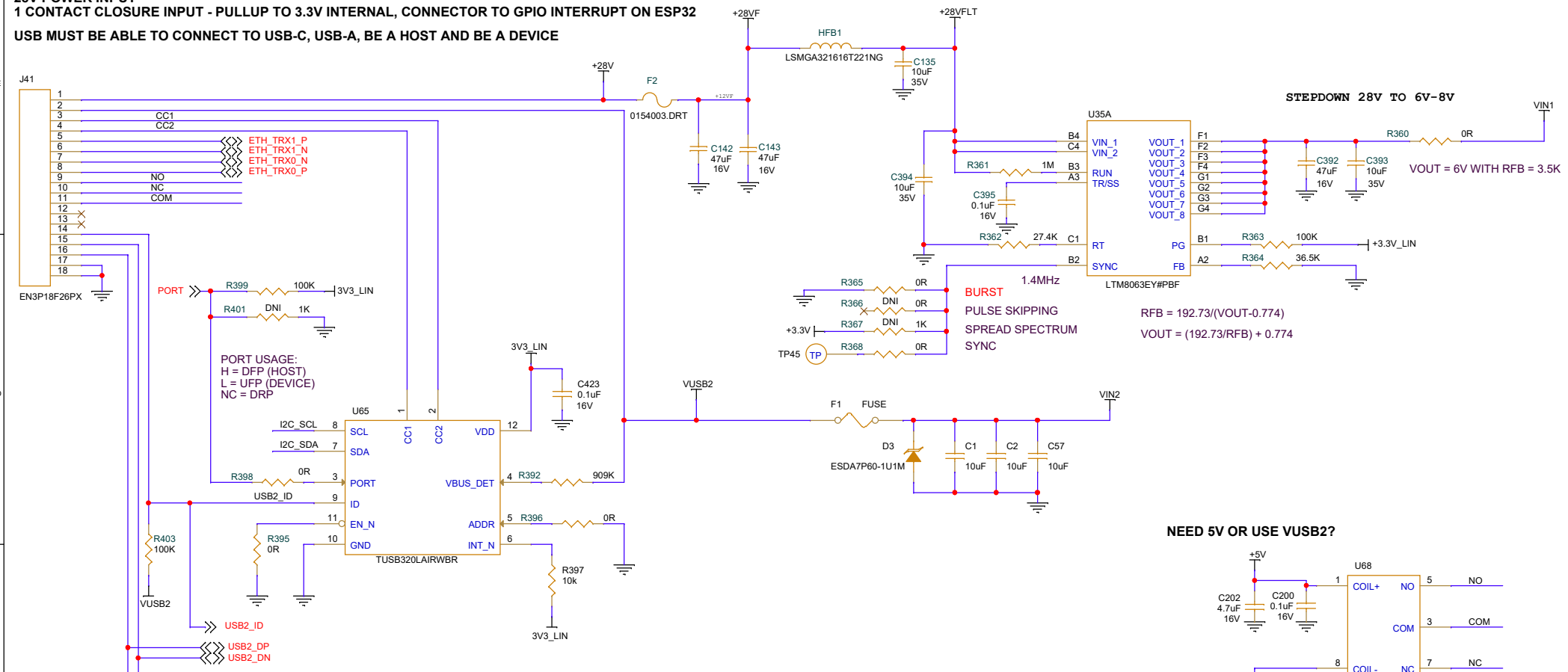

DROPOUT VOLTAGE = 200mV TYP @500ma
Iq = 20uA@0ma, 100uA@500ma

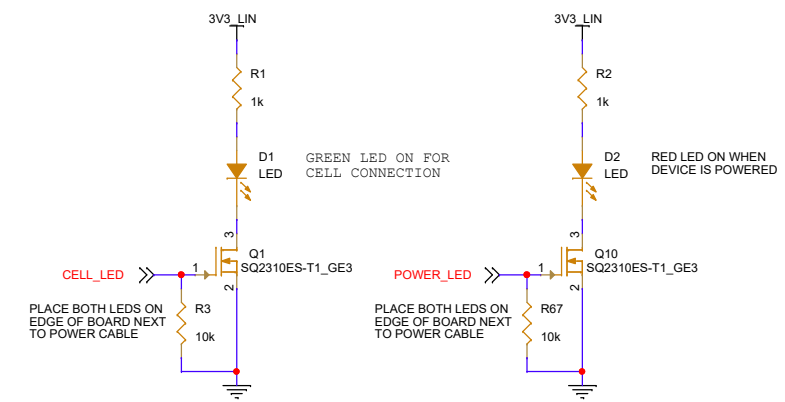
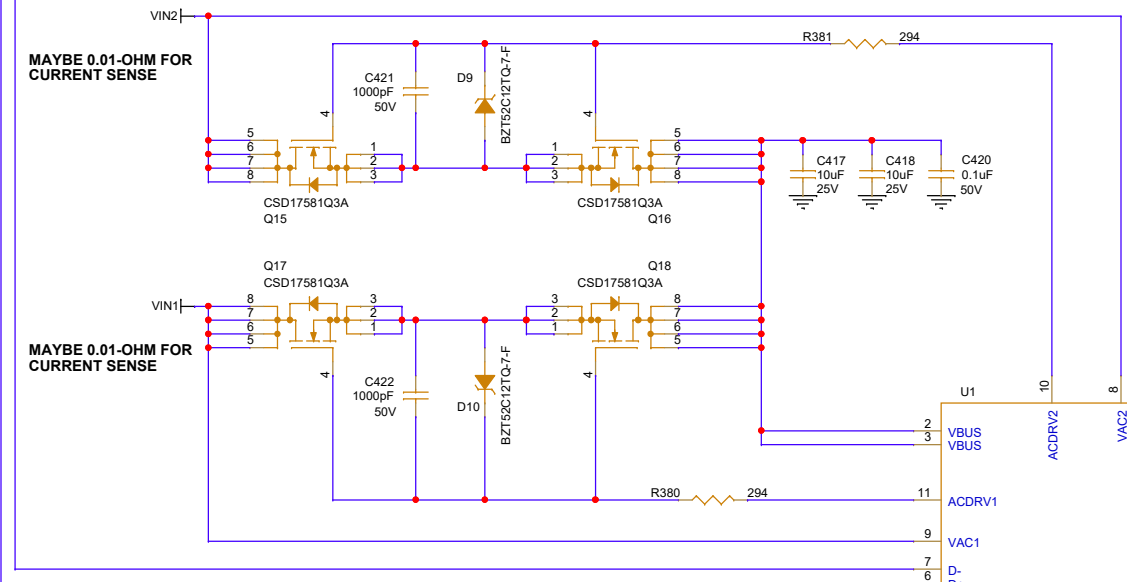
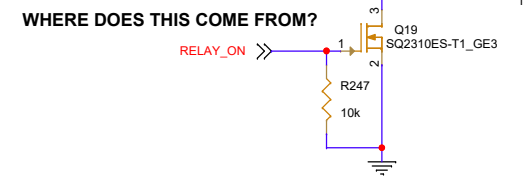
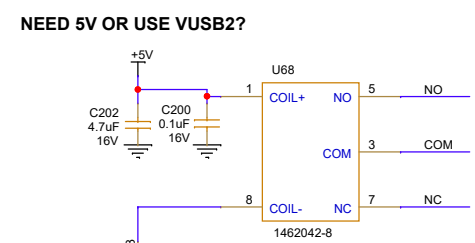
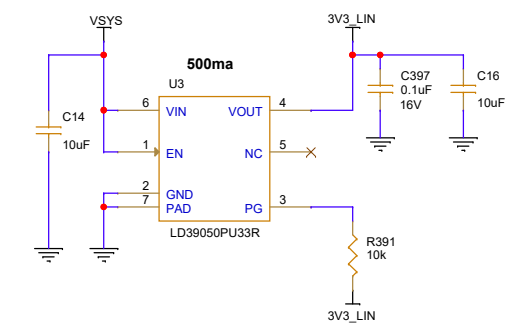

GOES TO DART AS WELL

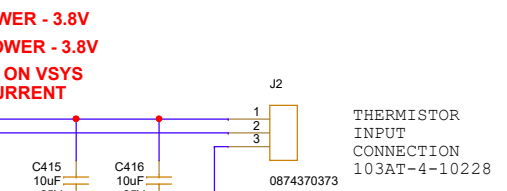
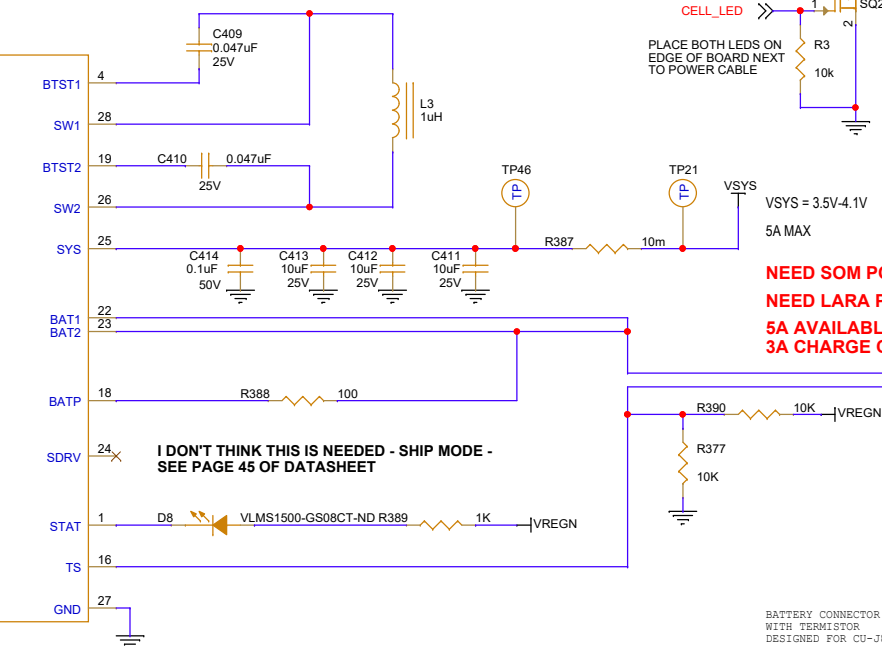
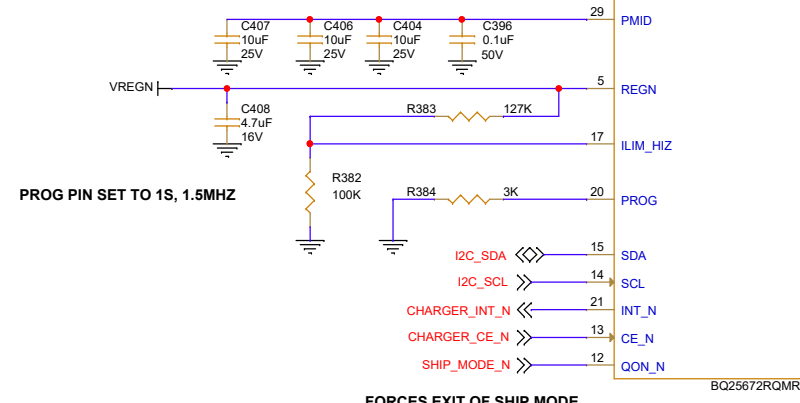

Title		02 - INPUT CONDITIONING	
Size	C	Document Number	<Doc>
Date:	Wednesday, January 03, 2024	Sheet	2 of 11
Rev	6		

BATTERY CONNECTOR FOR BAT WITH THERMISTOR. DESIGNED FOR CU-3890-V1 FROM BATTERYSPACE.COM