

## WEBENCH<sup>®</sup> Transformer Report

Design : 7 UC3845N  
UC3845N 85V-265V to 15.00V @ 4A

#	Name	Value
1.	Core Part Number	150-1680
2.	Core Manufacturer	Würth Elektronik
3.	Coil Former Part Number	070-5080
4.	Coil Former Manufacturer	Würth Elektronik

### Transformer Electrical Diagram

#### Primary

Turns	29.0
AWG	26.0
Layers	2.0
Strands	2.0
Insulation Type	Heavy Insulated Magnet Wire

#### Auxiliary

Turns	8.0
AWG	28.0
Layers	1.0
Strands	4.0
Insulation Type	Heavy Insulated Magnet Wire

#### Secondary

Turns	10.0
AWG	26.0
Layers	1.0
Strands	2.0
Insulation Type	Triple Insulated

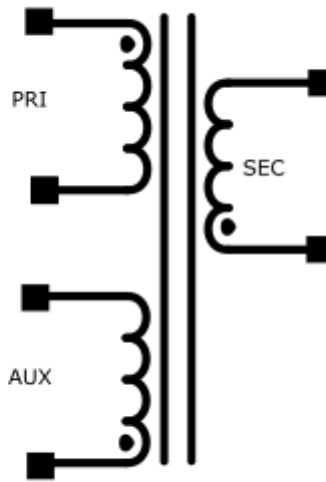

### Transformer Construction Diagram

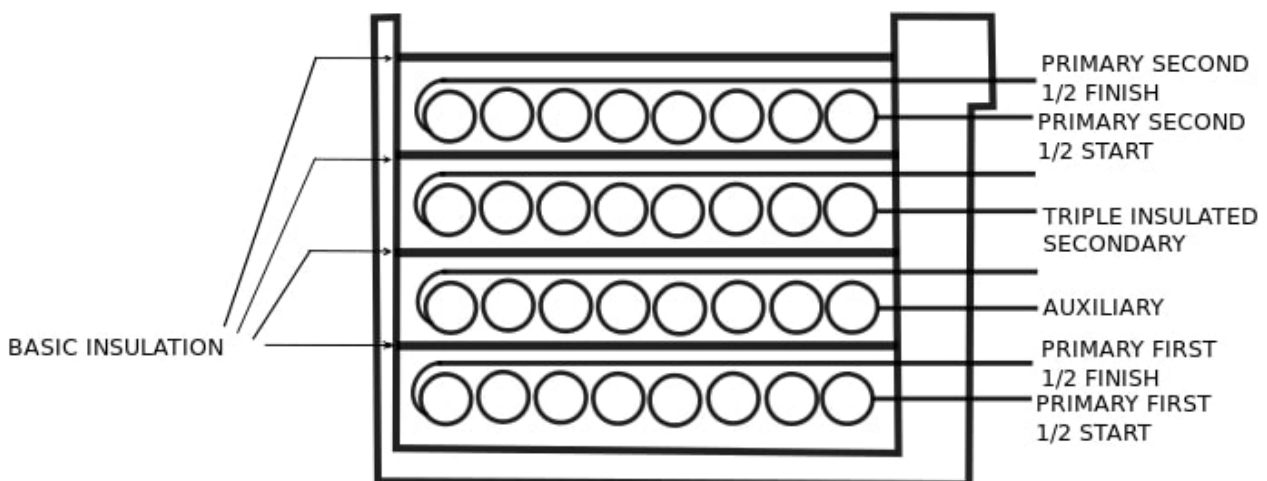

### Winding Instruction

Winding	AWG	Turns	Winding Orientation
Primary First 1/2.0	26.0	15	Clockwise
Auxiliary	28.0	8.0	Counter Clockwise
Triple Insulated Secondary	26.0	10.0	Counter Clockwise
Primary Second 1/2.0	26.0	14	Clockwise

## Transformer Parameters

#	Name	Value
1.	Lpri	1.37E-4H
2.	Inductance Factor(AI)	163.0nH
3.	Npri	29.0
4.	Nsec	10.0
5.	Naux	8.0
6.	Core Type	EE25/13/11
7.	Core Material	TP4A
8.	Bmax	0.20T
9.	Switching Frequency	99.31kHz
10.	DMax	0.36
11.	Ipk(Primary)	3.27A
12.	Irms(Primary)	1.24A
13.	Ipk(Secondary)	9.49A
14.	Irms(Secondary)	4.81A

## Design Assistance

1. **UC3845** Product Folder : <http://www.ti.com/product/UC3845> : contains the data sheet and other resources.

### Important Notice and Disclaimer

TI provides technical and reliability data (including datasheets), design resources (including reference designs), application or other design advice, web tools, safety information, and other resources AS IS and with all faults, and disclaims all warranties. These resources are intended for skilled developers designing with TI products. You are solely responsible for (1) selecting the appropriate TI products for your application, (2) designing, validating and testing your application, and (3) ensuring your application meets applicable standards, and any other safety, security, or other requirements.

These resources are subject to change without notice. TI grants you permission to use these resources only for development of an application that uses the TI products described in the resource. Other reproduction and display of these resources is prohibited. No license is granted to any other TI intellectual property right or to any third party intellectual property right. TI disclaims responsibility for, and you will fully indemnify TI and its representatives against, any claims, damages, costs, losses, and liabilities arising out of your use of these resources.

Providing these resources does not expand or otherwise alter TI's applicable Terms of Sale or other applicable terms available either on ti.com or provided in conjunction with TI products.