

电源电压范围:  
6VDC~110VDC;

### LLC功率电路

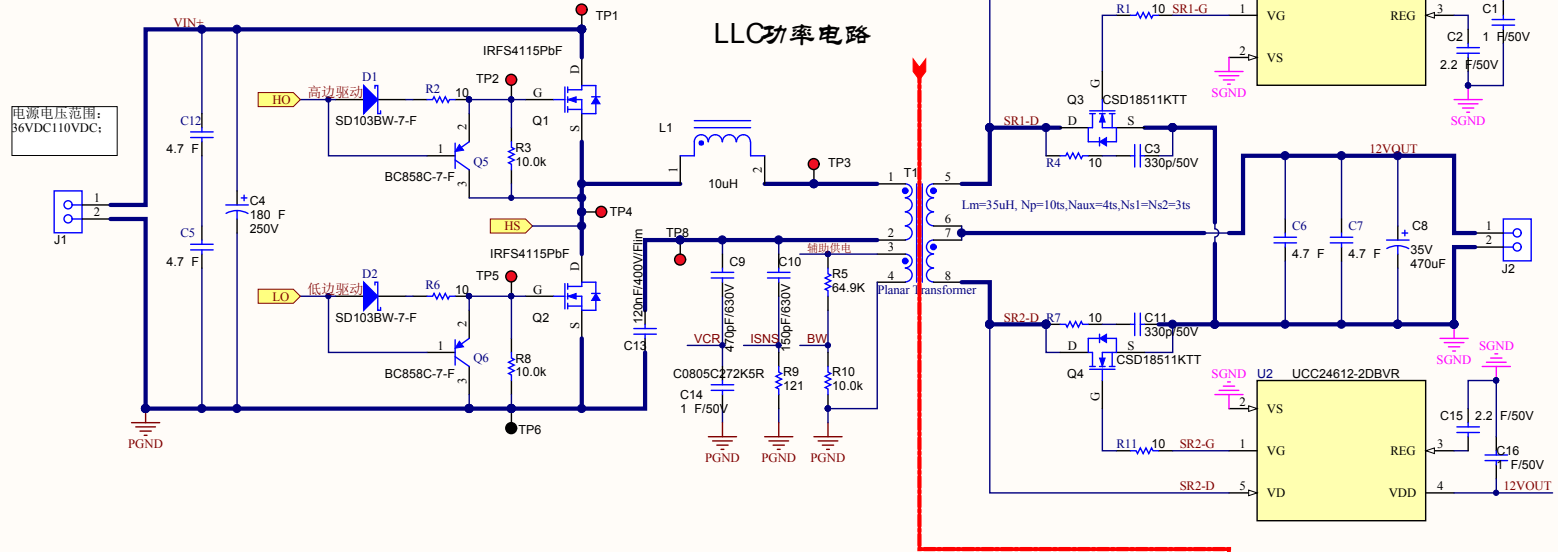

输出电压12V, 额定功率50W;

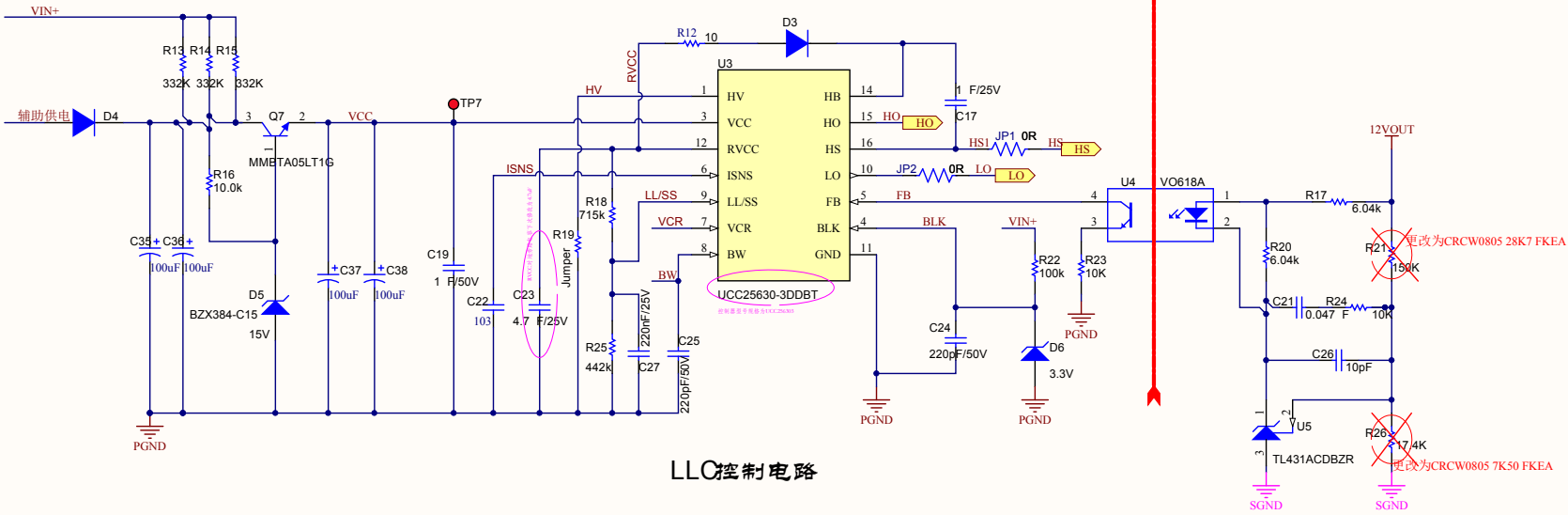

### LLC控制电路

型号规格	Designator	Footprint	Quantity	备注
	L1	RESONANT inductor	1	谐振电感参数计算
2-Pin接线端子	J1, J2	2-Pin 接线端子	2	
5000	TP1, TP2, TP3, TP4, TP5, TP7, TP8	Keystone5000	7	
5001	TP6	Keystone5001	1	
7343-D 35V/100uF	C35, C36, C37, C38	7343-D	4	
08055A100JAT2A	C26	0805	1	
08055C473JAT2A	C21	0805	1	
BC858C-7-F	Q5, Q6	SOT-23	2	
BZX384-C15,115	D5	SOD-323	1	
C0805C103K5RACTU	C22, C27	0805	2	103, [NoValue]
C0805C105K5R	C1, C16, C19	0805	3	
C0805C221K5RACTU	C24, C25	0805	2	
C0805C225K5R	C2, C15	0805	2	
C0805C272K5R	C14	0805	1	
C0805C331K5R	C3, C11	0805	2	
C2012X6S1H105K125AB	C17	0805	1	
C2012X6S1H475K125AB	C23	0805	1	
C3225X7S2A475K200AE	C5, C6, C7, C12	1210	4	
CRCW0805-0000-ZKEA	R19	0805	1	
CRCW0805-6K04-FKEA	R17, R20	0805	2	
CRCW0805-10K0-FKEA	R23, R24	0805	2	
CRCW0805-64K9-FKEA	R5	0805	1	
CRCW0805-442k-FKEA	R25	0805	1	
CRCW0805-715k-FKEA	R18	0805	1	
CRCW080510K0FKEA	R3, R8, R10, R16	0805	4	
CRCW080510R0JNEA	R1, R2, R4, R6, R7, R11, R12	0805	7	
CRCW080517K4FKEA	R26	0805	1	更改为CRCW0805 7K50 FKEA
CRCW0805121RFKEA	R9	0805	1	
CRCW0805150KFKEA	R21	0805	1	更改为CRCW0805 28K7 FKEA
CRCW1206100KFKEA	R22	1206	1	
CRCW1206332KFKEA	R13, R14, R15	1206	3	
CSD18511KTT	Q3, Q4	DDPAK	2	
ECQ-E4-124JF	C13	ECQE_1200x1290x600	1	谐振电容参数计算, 参数选型
EKXJ251ELL181MM25S	C4	EKXJ251ELL181MM25S	1	
ES1JAF	D3, D4	SMAF	2	
GRM31A5C2J151JW01D	C10	1206	1	
GRM31A5C2J471JW01D	C9	1206	1	
IRFS4115PbF	Q1, Q2	DDPAK	2	
MMBTA05LT1G	Q7	SOT-23	1	
MMSZ4684T1G	D6	SOD-123	1	
Planar Transformer	T1	transformer	1	Lm=35uH, Np=10ts,Naux=4ts,Ns1 =Ns2=3ts
SD103BW-7-F	D1, D2	SOD-123	2	
TL431ACDBZR	U5	DBZ0003A_N	1	
UCC24612-2DBVR	U1, U2	DBV0005A_N	2	
UCC25630-3DDBT	U3	DDB0014A	1	
UHW1V471MPD	C8	HW_1000x1600	1	
Used in BOM report	JP1, JP2	JP	2	
VO618A	U4	DIP-4	1	