

LOW POWER SYSTEM

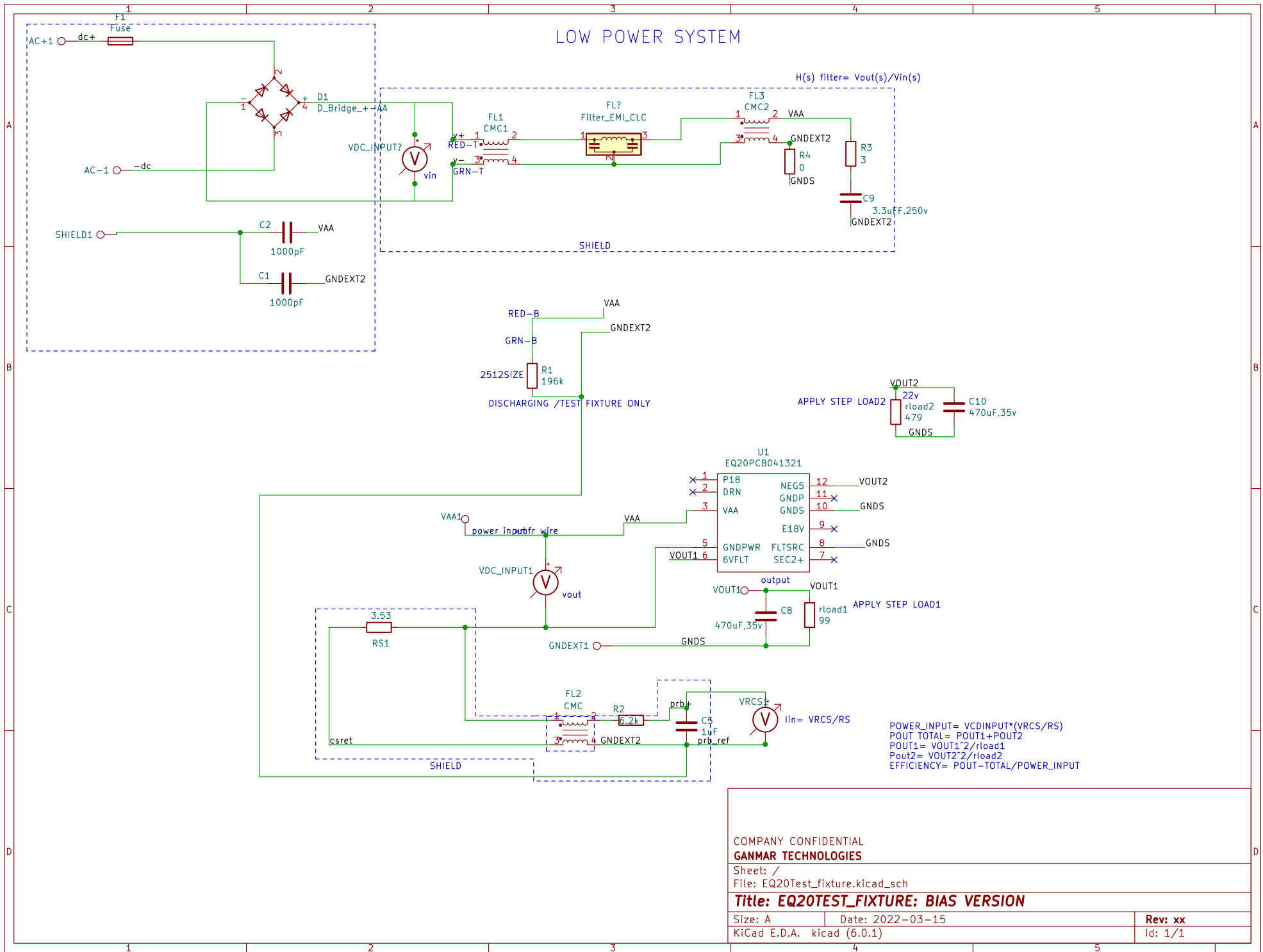

COMPANY CONFIDENTIAL
GANMAR TECHNOLOGIES

Sheet: /
File: EQ20Test_fixture.kicad_sch

Title: EQ20TEST_FIXTURE: BIAS VERSION

Size: A Date: 2022-03-15
KiCad E.D.A. kicad (6.0.1)

Rev: xx
Id: 1/1