

File Name	File number	Customer Code	Ver	Date	Product Category	Page
Product Specifications	GPT/RD.SPC-07576	F2003	0.1	2017-05-05	Polymer Li-ion Rechargeable Battery	1/11

Hangzhou Future Power Technology Co., Ltd

杭州金色能源科技有限公司

Product Specifications

产品规格书

Customer Model/客户型号: FT601220P/90mAh

Prepared By/Date 编制/日期	Checked By/Date 审核/日期	Approved By/Date 批准/日期
Lou Mengyao/楼梦瑶 2017-05-05	Li Xiyang/李晰阳 2017-05-05	Guo Yeping/郭也平 2017-05-05

客户确认:

Customer Approval:

客户确认:

Signed By/Date 签字/日期	Checked By/Date 审核/日期	Approved By/Date 批准/日期

*Remark: PACK Model/PACK 型号: FT601218PP/90mAh

File Name	File number	Customer Code	Ver	Date	Product Category	Page
Product Specifications	GPT/RD.SPC-07576	F2003	0.1	2017-05-05	Polymer Li-ion Rechargeable Battery	2/11

History of revisions

修订历史

Ver 版本号	Issued Date 发行日期	Content of Amendment 修订事项	Revisor 修订	Approved 批准
0.1	2017-05-05	Probationary issue 临时版发行	Lou Mengyao 楼梦瑶	Guo Yeping 郭也平

File Name	File number	Customer Code	Ver	Date	Product Category	Page
Product Specifications	GPT/RD.SPC-07576	F2003	0.1	2017-05-05	Polymer Li-ion Rechargeable Battery	3/11

Contents 目录

1. Scope 适用范围	4
2. Test condition 测试条件	4
3. Basic Product Characteristics 产品基本特性	4
4. Initial External Dimension 初始外形尺寸	5
5. Appearance 外观	5
6. Basic Electrical Characteristics 基本电性能	5
7. Safety Characteristics 安全特性	6
8. Reliability Characteristics 可靠性特性	7
9. Period of Warranty 保质期	7
10. Parameter of PCM 保护板参数	7
11. External Dimension Drawing PACK 电池尺寸示意图	9
12. Matters needing attention 电池使用注意事项	9
13. Relation Information 联系方式	11

File Name	File number	Customer Code	Ver	Date	Product Category	Page
Product Specifications	GPT/RD.SPC-07576	F2003	0.1	2017-05-05	Polymer Li-ion Rechargeable Battery	4/11

1. Scope 适用范围

This specification shall be applied to polymer Li-ion Rechargeable Battery manufactured by Hangzhou Future Power Technology Co., Ltd.

本规格书适用于由杭州金色能源科技有限公司生产的聚合物锂离子充电 PACK 电池。

2. Test condition 测试条件

2.1 Normal environmental test conditions 常规测试环境条件

Temperature温度: 23±2℃, Relative Humidity湿度: 45-75%RH, Atmospheric pressure气压: 86 -106 KPa

2.2 Product specification 产品说明

Product should be fresh unused within 30days after shipment.

产品需为出货后 30 天内未使用过的新鲜电池。

3. Basic Product Characteristics 产品基本特性

No.序号	Item 项目	Characteristics 特性
3.1	Rated Capacity 额定容量(C _R)	90mAh
	Minimal Capacity(C _{min})最小容量	90mAh
3.2	Rated Voltage 额定电压	3.7V
3.3	Initial Internal Impedance 初始内阻	≤450mΩ (AC impedance @1kHz, 50% SOC, 23±2℃)
3.4	Limited Charging Voltage 充电限制电压	4.20 ^{+0.03} _{-0.02} V
3.5	Discharging Cut-off Voltage 放电终止电压	3.0V
3.6	Standard Charging 标准充电	0.5C ₅ A (45mA) CC(constant current) charge to Charge Limited Voltage, then CV(constant voltage) charge till charge current decline to 0.02 C ₅ A at 23±2℃. 23±2℃下, 0.5C ₅ A (45mA)恒流充电至充电限制电压, 然后恒压充电至 0.02 C ₅ A。
3.7	Standard Discharging 标准放电	0.2C ₅ A (18mA) discharge to the Discharge Cut-off Voltage at 23±2℃. 0.2C ₅ A (18mA)恒流放电至放电终止电压 (环境温度: 23±2℃)
3.8	Maximum Charging Current 最大充电电流	0~10℃ 0.2C/4.1V 0.02 C ₅ A cut-off 10~45℃ 1.0C/4.2V 0.02 C ₅ A cut-off
3.9	Maximum Discharging Current 最大放电电流	-20~0℃ 0.2 C ₅ A 0~60℃ 1 C ₅ A
3.10	Operating Temperature Range 工作温度范围	Charge 充电 0~ 45℃ Discharge 放电 - 20 ~ 60℃
	Storage Temperature Range 储存温度范围	-20 ~ 60℃≤1month; -20 ~ 45℃≤3months; -20 ~ 30℃≤12months (50±10)% SOC
3.11	Weight 重量	Approx. 约 3.0g

File Name	File number	Customer Code	Ver	Date	Product Category	Page
Product Specifications	GPT/RD.SPC-07576	F2003	0.1	2017-05-05	Polymer Li-ion Rechargeable Battery	5/11

4. Initial External Dimension 初始外形尺寸

Item 项目	Dimension 尺寸 (mm)
T	Max 6.0
W	Max 12.3
L1	Max 19.5
L2	8±1
M	5±1.5
N	2.0±0.2

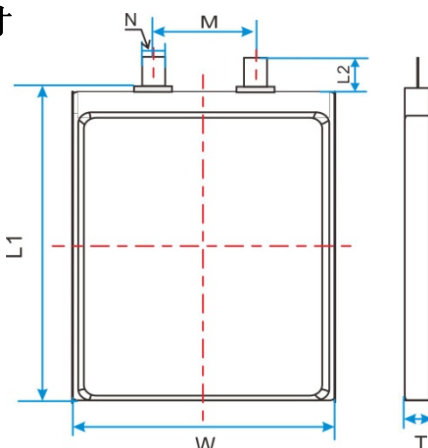

5. Appearance 外观

It shall be free from any defects which may affect commercial value of the battery such as remarkable scratches, cracks, deformation, and leakage. 电池表面无划伤、裂纹、污渍、变形、漏液等等影响电芯常规性能的缺陷存在。

6. Basic Electrical Characteristics 基本电性能

No. 序号	Items 项目	Criteria 标准	Test Method 测试方法
6.1	Initial Shipment Voltage 出货电压	3.75V~3.90V	Measure with voltmeter. 使用电压表进行测量。
6.2	Minimal Capacity(Cmin) 最小容量	≥90mAh	Standard Discharge after Standard Charge and rest 10min. 电池标准充电后静置 10 min 再标准放电。
6.3	1C ₅ A Discharge Capacity 1C ₅ A 放电容量	≥90%×Cmin	1C ₅ A discharge to the Discharge Cut-off Voltage after Standard Charge and rest 10min. 电池标准充电后静置 10 min 再 1C ₅ A 放电
6.4	Temperature Characteristics 温度特性	Discharge Capacity 放电容量: 55℃: ≥85%×Cmin 0℃: ≥80%×Cmin -10℃: ≥60%×Cmin	After Standard Charge, the battery is stored at (-10 ± 2)℃ for 4hours, and then at the same temperature 0.2C ₅ A discharges to the Discharge Cut-off Voltage. According to this procedure, test (0 ± 2)℃, (55 ± 2)℃ discharge capacity, respectively. 将标准充电的电池放在(-10±2)℃下搁置 4h, 然后再在相同温度下以 0.2C ₅ A 放电至终止电压, 测试该温度下的放电容量。按照此流程, 再测试(0±2)℃、(55±2)℃下的放电容量。

File Name	File number	Customer Code	Ver	Date	Product Category	Page
Product Specifications	GPT/RD.SPC-07576	F2003	0.1	2017-05-05	Polymer Li-ion Rechargeable Battery	6/11

6.5	Storage Characteristics 荷电保持能力	Retention Capacity 剩余容量: $\geq 85\% \times C_{min}$	After Standard Charge, the battery is stored for 28 days, and then 0.2 C ₅ A discharges to the Discharge Cut-off Voltage to test retention capacity. 将标准充电的电池搁置 28 天后, 以 0.2C ₅ A 恒流放电至终止电压以测试剩余容量。
6.6	Cycle Life 循环寿命	Discharge Capacity(301 th cycle) 放电容量 $\geq 80\% \times C_{min}$	A cycle is defined as a Standard Charge, 10 minute-rest and Standard Discharge.The battery is to be cycled for 301 times. 一个充放电循环被定义为: 电池标准充电后, 静止 10min, 然后标准放电。按照此定义将电池循环 301 次。

7. Safety Characteristics 安全特性

No. 序号	Items 项目	Criteria 标准	Test Method 测试方法
7.1	Over-charge 过充性能	No fire. No explosion. 电池不起火、不爆炸。	Charging to 6V with Maximum Charging Current after Standard Discharge, then CV Charge till current decline to End-of-Charge Current or CV time is more than 7hours. 电池标准放电后, 以最大电流充电至 6V, 然后再在 6V 下恒压充电 7h。
7.2	Short-Circuit 短路性能	The maximum Temperature: $\leq 150^{\circ}\text{C}$. No fire. No explosion. 最高温度 $\leq 150^{\circ}\text{C}$, 电池不起火、不爆炸。	Rest for 30minutes at $(55\pm 2)^{\circ}\text{C}$ after Standard Charge, then short-circuit battery by connecting the positive and negative terminals with a circuit load having a resistance load(copper wire) of $80\pm 20\text{m}\Omega$.Test can be terminated when battery surface temperature has returned to $\pm 10^{\circ}\text{C}$ of environment temperature. 电池标准充电后, 将电池在 $(55\pm 2)^{\circ}\text{C}$ 的温度下恒温 30min, 然后用铜导线(总电阻 $80\pm 20\text{m}\Omega$)短接其正负极, 当电池表面温度恢复至高于环境温度 10°C 以内时, 结束实验。
7.3	Thermal Abuse 热滥用性能	No fire. No explosion. 电池不起火、不爆炸	The battery is to be heated in a gravity convection or circulating air oven after Standard Charge. The temperature of the oven is to be raised at a rate of $5\pm 2^{\circ}\text{C}$ per minute to a temperature of $130 \pm 2^{\circ}\text{C}$ and remain for 10 minutes. 将标准充电后的电池放入鼓风式烘箱内, 以 $(5\pm 2)^{\circ}\text{C}/\text{min}$ 的速率由室温升温至 $(130\pm 2)^{\circ}\text{C}$, 并在此温度下恒温 10min。

File Name	File number	Customer Code	Ver	Date	Product Category	Page
Product Specifications	GPT/RD.SPC-07576	F2003	0.1	2017-05-05	Polymer Li-ion Rechargeable Battery	7/11

8. Reliability Characteristics 可靠性特性

No. 序号	Items 项目	Criteria 标准	Test Method 测试方法
8.1	Static Humidity and Temperature 恒定湿热性能	Retention Capacity 剩余容量: $\geq 80\% \times C_{min}$ Recoverable Capacity 恢复容量 $\geq 85\% \times C_{min}$ No deformation. No rupture. No smoke. No leakage. 无明显变形、冒烟或破裂, 不漏液。	After Standard Charge, the battery is stored at $40 \pm 2^\circ\text{C}$ and 90%-95%RH for 48hours, then rest for 2hours at $23 \pm 2^\circ\text{C}$. Standard Discharge to test its retention capacity, and then perform a cycle with Standard Charge and Standard Discharge procedure to test recoverable capacity. 电池标准充电后, 在温度为 $(40 \pm 2)^\circ\text{C}$, 相对湿度为 90%~95%的条件下开路搁置 48h, 然后在 $23 \pm 2^\circ\text{C}$ 条件下开路搁置 2h, 目测外观; 标准放电至终止电压, 记录剩余容量; 然后电池进行一次标准充放电循环测试可恢复容量。
8.2	Vibration 振动	OCV $\geq 3.6\text{V}$ 电压 $\geq 3.6\text{V}$ No leakage. No fire. No explosion. 电池不漏液、不起火、不爆炸。	After Standard Charge, the battery is fixed to vibration table and subjected to vibration cycling that the frequency is to be varied at the rate of 1Hz per minute between 10Hz and 55Hz, the excursion of the vibration is 1.6mm. The battery shall be vibrated for 30 minutes per axis of XYZ axes. 将标准充电后的电池固定在振动台上, 沿 X、Y、Z 三个方向各振动 30 分钟, 振幅 1.6mm, 振动频率为 10Hz~55Hz, 每分钟变化 1Hz。
8.3	Drop 自由跌落	OCV $\geq 3.6\text{V}$ 电压 $\geq 3.6\text{V}$ No leakage. No fire. No explosion. 不漏液、不起火、不爆炸。	After Standard Charge, the battery is to be dropped from a height of 1 meter onto concrete board for 6 times, then measure Open Circuit Voltage. 将标准充电后的电池从 1.0m 高处自由跌落在到混凝土板上 6 次; 跌落完成后, 测试电池开路电压。

9. Period of Warranty 保质期

Period of warranty is 12 months from the date of manufacture. Future Power guarantees to give 1 to 1 replacement in case of the batteries with manufacture defects. No replacement for defects caused by customer's abuse or misuse.

保质期为自生产日期开始算起后的 12 个月。本公司承诺由于电池本身的问题, 本公司负责进行一对一的调换, 如果是由于用户滥用或误用而产生的问题, 不予调换。

10. Parameter of PCM 保护板参数

10.1 List of Parameter 保护板参数清单

Parameter 参数	Min.最小值	Typ.典型值	Max.最大值	Unit 单位
Overcharge Detection Voltage 过充电保护电压	4.25	4.30	4.35	V
Overcharge Detection Delay Time 过充电保护延迟时间	40		200	ms

File Name	File number	Customer Code	Ver	Date	Product Category	Page
Product Specifications	GPT/RD.SPC-07576	F2003	0.1	2017-05-05	Polymer Li-ion Rechargeable Battery	8/11

Over discharge Detection Voltage 过放电保护电压	2.3	2.4	2.5	V
Over discharge Detection Delay Time 过放电保护延迟时间	20		100	ms
Discharge Over Current Detection 放电过电流保护	1.5		4.5	A
Over Current Detection Delay Time 过电流保护延迟时间	5		20	ms
short circuit Detection Delay Time 短路保护延迟时间	5		50	μ s
Normal current consumption 自耗电			6	μ A
Impedance 内阻			65	m Ω

10.2 List of PCB BOM 保护板元件清单

No. 序号	Element Code	Part Number 物料名称	Type/Specification 型号/规格	Qty. 数量
1	U1	Protection IC 贴片保护 IC	DW01+G	1
2	U2	MOSFET	8205	1
3	R1	Resistor 贴片电阻	100 Ω , \pm 5%, 1/16W	1
4	R2	Resistor 贴片电阻	1K Ω , \pm 5%, 1/10W	1
5	C1C2	Capacitor 贴片电容	0.1uf, \pm 10%,X7R,16V	2
6		PCB 保护板		1

10.3 Circuit Diagram 保护板原理图

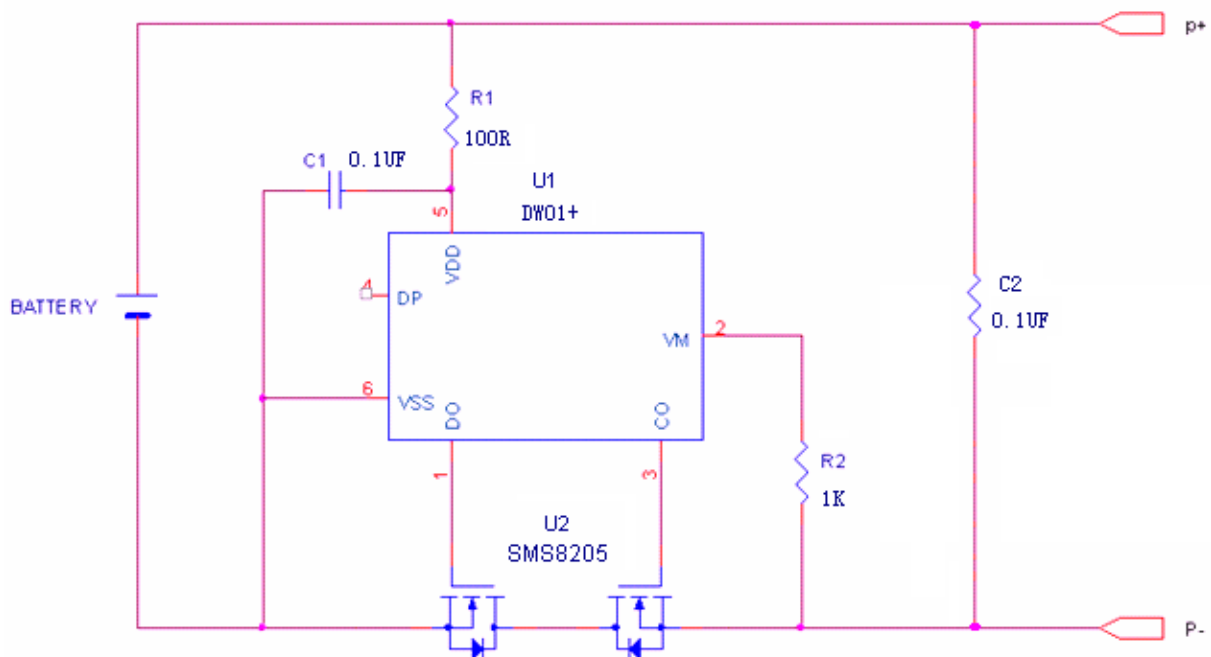

File Name	File number	Customer Code	Ver	Date	Product Category	Page
Product Specifications	GPT/RD.SPC-07576	F2003	0.1	2017-05-05	Polymer Li-ion Rechargeable Battery	9/11

11. External Dimension Drawing PACK 电池尺寸示意图

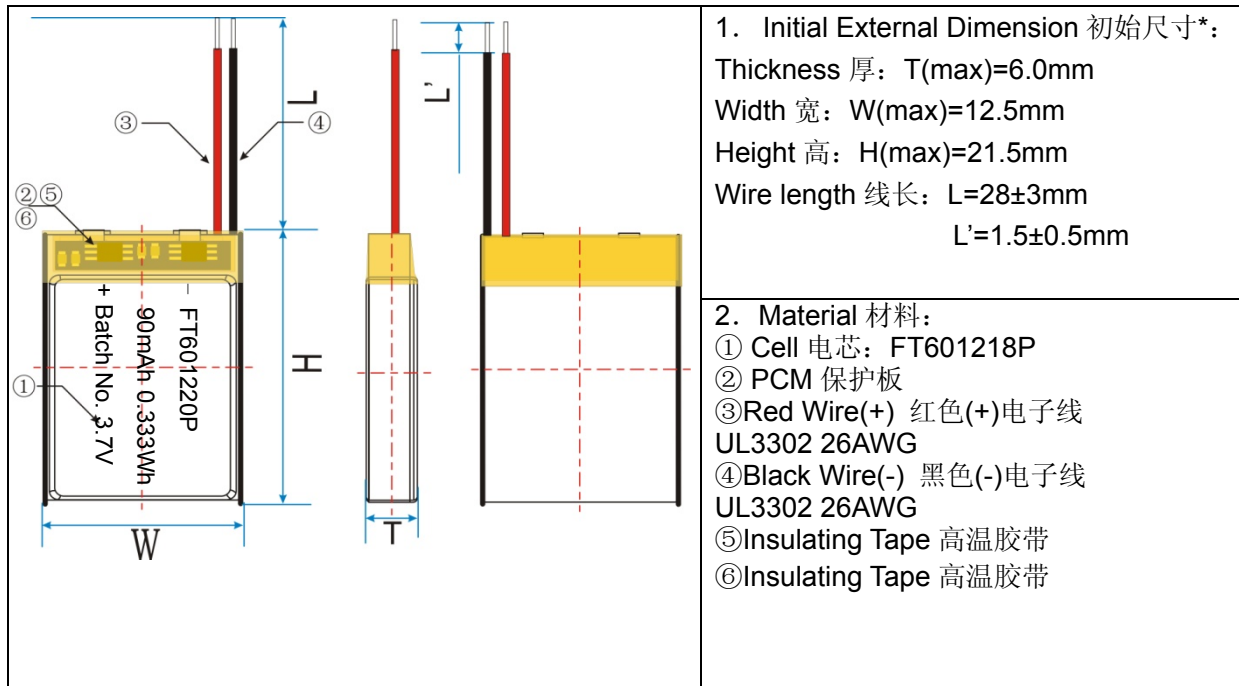

* Test Condition See Item2, SOC as of shipment Voltage 检测条件见 Item2,荷电态为出货电压下状态

12. Matters needing attention 电池使用注意事项

Please strictly observe the product specifications' requests. Otherwise Future Power will not take any responsibility due to customer's abuse or misuse.

必须严格按照本规格书要求，由于用户滥用或误用，杭州金色能源科技有限公司不承担任何责任。

! Danger ! 危险

Never heat battery or throw it into fire.

- 严禁把将电池投进火中或进行加热。

Never throw battery in liquid such as water、gasoline or drink etc, also do not wet battery

- 严禁把电池投入液体中，如水、汽油、饮料等，也不要吧电池弄湿。

Prohibition of use battery close to fire or in a car where temperature may be above 60°C . Also do not charge / discharge in such conditions.

- 禁止在火源附近或温度超过 60°C 的轿车中使用或遗留电池，也不要这些环境中进行充放电。

Never put batteries in your pockets or a bag together with metal objects such as necklaces, Hairpins, coins, or screws. Do not store or transport batteries with such objects.

- 禁止把电池同项链、发夹、硬币或螺钉等金属品一起放在兜中或包中，也不要吧电池同上述物品一起储存或运输。

Never short-circuit the (+) and (-) terminals with other metals.

- 禁止使用金属导体短路电池的正负极。

Do not place battery in a device with the (+) and (-) in the wrong way around.

- 在装入设备时注意电池的正负极不要反装。

Do not pierce battery with a sharp object such as a needle.

- 禁止使用锐利的物品刺穿电池。

Do not disassemble the battery.

File Name	File number	Customer Code	Ver	Date	Product Category	Page
Product Specifications	GPT/RD.SPC-07576	F2003	0.1	2017-05-05	Polymer Li-ion Rechargeable Battery	10/11

- 禁止对电池进行分解。

Never weld a battery directly.

- 禁止直接对电池进行焊接。

Do not use a damaged battery.

- 禁止使用已经损坏的电池。

Please carefully read the user's manual prior to use to avoid deteriorated performance, even battery leakage, heat, smoke, fire, explosion due to wrong operations.

- 在使用之前请详细阅读操作说明书，不适当的操作可能引起电池变热、着火、爆炸、毁坏或电池容量的衰减。

! Warning! 警告

Do not put battery into a microwave oven, dryer, or high-pressure container.

- 禁止把电池放加热器皿、洗衣机或高压容器中。

Never use battery with dry battery and other primary batteries. Also do not use mixed battery/batteries with different package, model, or brand.

- 禁止把电池同干电池或其它原电池或者新旧电池一起使用，也不要同不同包装、不同型号或不同品牌的电池一起使用。

Stop charging the battery if charging is not completed within the specified time.

- 如果在规定的充电时间内充电没有结束，停止充电。

Stop using the battery if abnormal heat, odor, discoloration, deformation or abnormal condition is detected during use, charge, or storage.

- 在使用、充电或储存期间如发现电池有变热、散发气味、变色、变形或其它反常之处停止使用。

Keep away from fire immediately when leakage or unpleasant smell is detected.

- 当发现电池漏液或散发出难闻的气味时立即远离。

If liquid leaks onto your skin or clothes, wash well with fresh water immediately.

- 如果电解液渗漏到您的皮肤或衣服上，立刻用大量清水冲洗。

If liquid leaking from the battery gets into your eyes, do not rub your eyes. Wash them well with fresh water and go to see a doctor immediately.

- 如果电解液渗出并进入您的眼睛里，不要揉擦您的眼睛，立刻用清水清洗眼睛并就医。

! Caution! 注意

Before using the battery, be sure to read the user's manual and cautions on handling thoroughly.

- 在使用电池之前，应详细阅读操作指南并对使用中的注意事项有足够深刻的理解。

Charge with specific charger according to product specification. Charge with CC/CV model. Reverse charging is prohibited, for it will deteriorate the battery performance and lead to safety issues such as heat and leakage.

- 充电时请使用指定的充电器并按照本规格书的要求进行充电。采用恒流恒压方式充电，禁止反向充电。同时，反向充电会降低电芯的充放电性能和安全性，并会导致发热和泄漏。

Keep batteries out of reach of children to avoid being swallowed.

- 把电池放到小孩够不到的地方以免吞服。

If children use the battery, their guardians should explain the proper handling.

- 小孩使用电池时，监护人应详细解释操作方法。

Batteries have life cycles. If battery powers equipment much shorter time than usual, please replace the

File Name	File number	Customer Code	Ver	Date	Product Category	Page
Product Specifications	GPT/RD.SPC-07576	F2003	0.1	2017-05-05	Polymer Li-ion Rechargeable Battery	11/11

battery with a new one.

- 电池具有使用寿命，如果使用电池的设备的工作时间比平常少的多，请更换新电池。

When not using battery for long terms, remove it from the equipment and store in a place with low humidity and low temperature.

- 当长期不用时，要将电池从设备中取出并放在低温低湿的环境中保存。

While the battery pack is charged, used and stored, keep it away from places/objects with static electric.

- 电池应在远离静电的场所进行充电、使用和储存。

If the terminals of battery become dirty, clean it with dry cloth before using.

- 如果电池的接线端变脏，在使用之前用干布擦净。

The batteries should be stored in drying and cooling place (see Item 2.1 and 3.10). It should be noted that the batteries would be over-discharged due to their self-discharge characteristics if they are not used for long time. In order to prevent over-discharge, the batteries shall be charged periodically (exceed three months) to maintain between 3.7V and 3.9V.

- 电池应储存在干燥和凉爽的地方（见 Item 2.1 and 3.10），需要注意的是如果电池长时间不使用时由于自放电特性将会过放；为避免过放，应定期（超过三个月）给电池充电以维持电压在 3.7V 到 3.9V 之间。

In condition of intense magnetic field, battery charging and discharging will be interfered to cause unsafe hidden troubles.

- 在强磁条件下，电池充放电时磁场和充放电电流将产生交变影响，带来不安全的隐患。

Suggest not to long term float-charging, especially in high temperature condition. Otherwise battery performance and cycle life will be deteriorated.

- 不建议电池长时间进行浮充，否则电池在长时间浮充特别高温环境下引起电池的性能和循环寿命恶化。

13. Relation Information 联系方式

Tel: 86-755-85215006

Fax: 86-755-85215302

Email: tom.peng@amtbattery.com